



Pure performance

STEADY® 1300 SERIES - 50HZ

Steady[™]
a xylem brand



Available

EASY TO SELECT, CLOSE AT HAND, RIGHT PUMP FOR YOUR NEEDS

Value for money

EFFICIENT, POWERFUL

Reliable

SOLIDS HANDLING, CONTINUOUS RUNNING

Readily available pure performance pumps

Steady® 1300 is a series of submersible pumps that deliver pure performance at outstanding value.

Combining performance and quality in a convenient, value for money package, these pumps will help ensure the smooth running and profitability of your operation. This is why Steady is the ideal pump for sewage and surface wastewater within municipal and commercial building applications.

Moreover, Steady makes your choice of pump easy, it only requires three straightforward steps. We have the right pump for your needs with high availability to support your business.

The Steady 1300 series is based on technology developed and tested in tough environments the world over. That's why you can count on these pumps for trouble-free, reliable operation.

The hydraulic design of the pumps has been proven to reduce clogging and maintain efficiency. These pumps simply work—and keep on working. Day in, day out, and under harsh conditions, they won't let you down—they're Steady.

Available Value for money Reliable

With a variety of model and Steady 1300 impeller combinations, it's easy to find a pump for your needs. The optimized impeller design ensures efficient solids handling capability, smooth operation, and increased savings from reduced maintenance costs and lower energy consumption.

All pumps in the series feature a motor designed for reliable operation in submersible applications. The motors have F-class insulation, which allows for

continuous running without overheating, ensuring optimal cooling and long lifetime. Additionally, the pumps can handle 15 starts per hour without problem.

Typically these pumps are installed in permanent installations. However, some models have the option of a free-standing installation so that the pump can be easily moved from one site to another. See methods of installation (page 6) for further reference.

Application areas

Municipal:

- Domestic sewage pumping stations
- Wastewater pumping stations
- Retention basins
- Storm water pumping stations

Commercial building:

- Drainage water
- Domestic sewage pumping stations
- Ground water

Tough to beat

Robust

All components are made from robust materials for easy maintenance and long life.

Powerful

Motor is specifically designed for reliable operation in submersible applications. It can run continuously without overheating - a true workhorse.

Durable

Heavy-duty bearings with long life provide peace of mind.

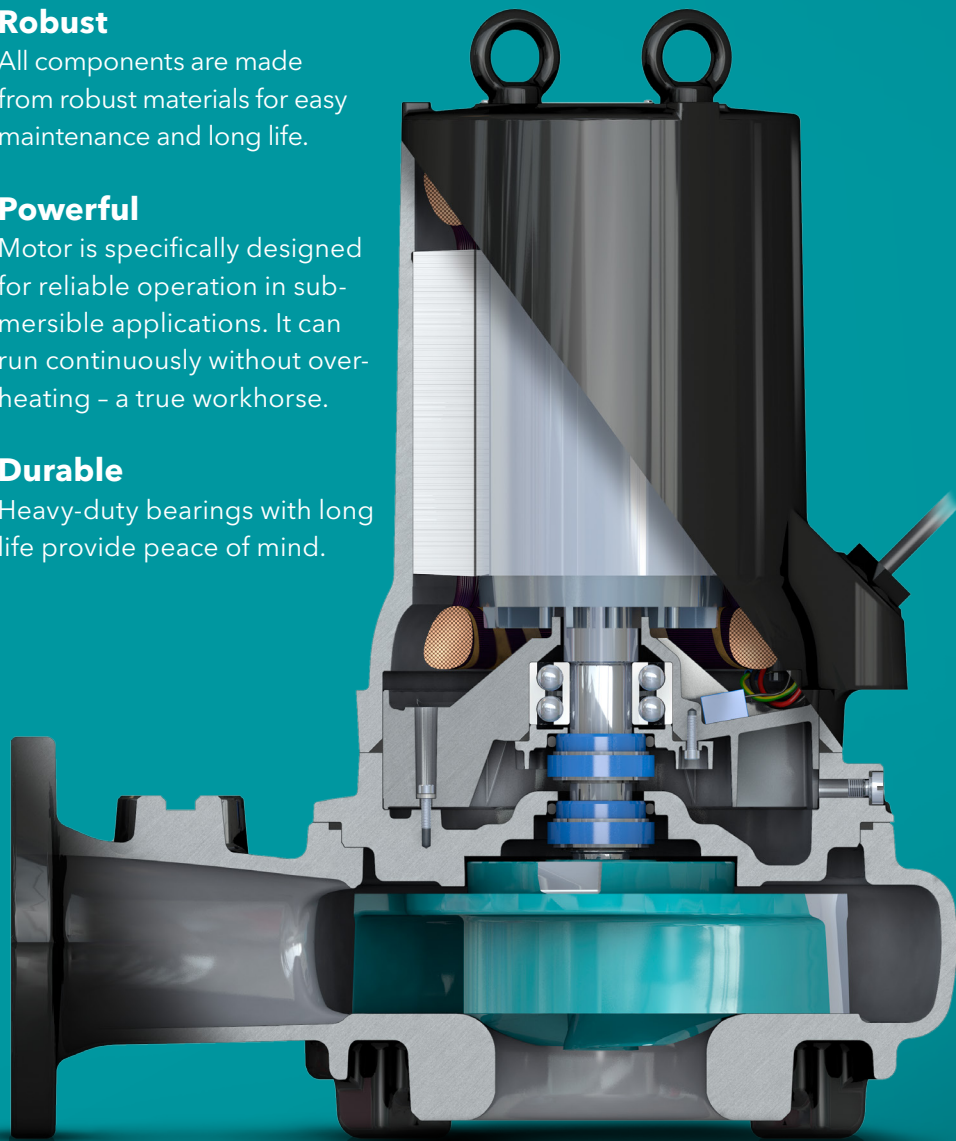

Environmentally friendly

Cooling system is designed to use the surrounding media to cool the pump; no use of environmentally hazardous fluids such as oils.

Safe and straightforward

Cable entry prevents both cable strain and leakage.

Smooth

The double mechanical seal provides extra reliability and protects against leakage.

Flexible

Drilled pump housing, ready for any installation method.

Installation methods and accessory kits

The Steady 1300 series is designed to fit your needs. You start with a bare pump and order the right kit depending on your desired installation method.

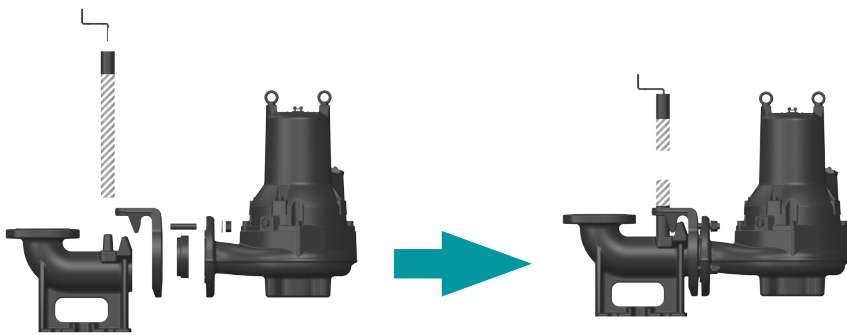

Wet-well kit

The pump is installed with twin guide bars on a discharge connection.

Kit contents:

- Discharge connection
- Anchor bolts
- Guide claw with bolts
- Upper guide bar bracket with bolts

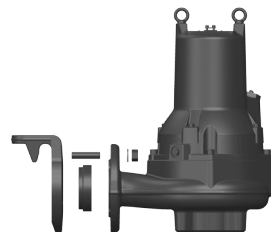
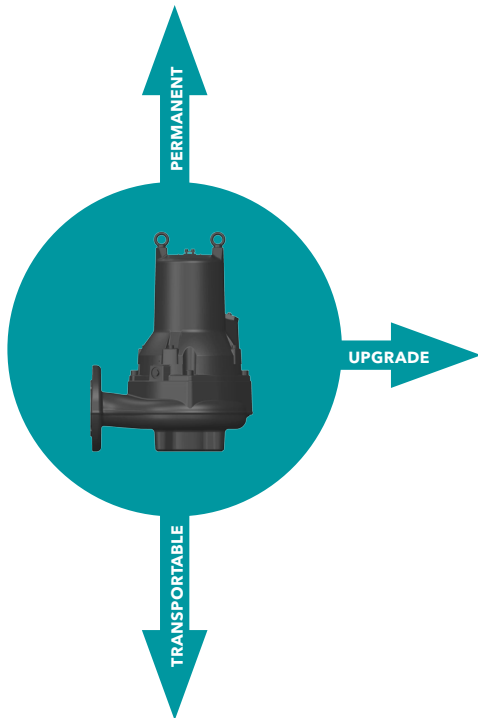

Replacement kit

Simple kit to replace an old pump or upgrade to a larger model

Kit contents:

- Guide claw with bolts

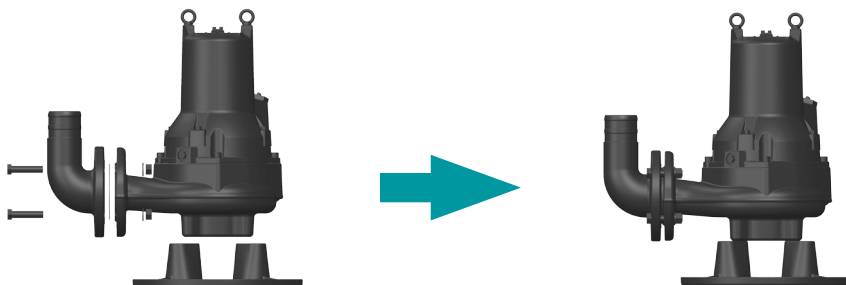

Free-standing kit

Ideal for portability

Kit contents:

- Hose connection with bolts
- Stand with bolts

Selecting & ordering

Configure your product order and generate order number

We've made it easy for you to select and configure your pump with appropriate accessories; it's done in just three simple steps and you build your order number as you go.

1 Select the pump model ideal for your needs from the product pages that follow.

2 For every model and choice of outlet dimension there is a partially filled order number. Configure your pump from the relevant selection tables and you will automatically get the information to build and complete your order number as you go!

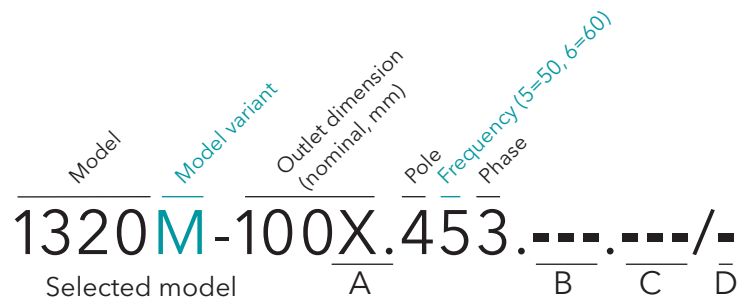

Steady™ 1320 Non-clog

Performance curves

Selection table

Model	DN	Installation*	Pole	Curve no.	Voltage	Cable	Order no.
1320S	80	X	2	4, 545, 547	380, 230	10	1320S-80
1320H	100	X	2	2, 543, 544, 546	380, 230	10	1320H-100
1320M	100	X	4	2, 524, 526	380, 230	10	1320M-100

*X-Bare pumps.

Pump Data

Model	1320S	1320H	1320M
Impeller Type	Non-clog	Non-clog	Non-clog
Outlet size (mm)	80	100	100
Weight (kg)	130	140	156
Pole	2	4	4
Insulation Class	F	F	F
Superficial Cable	15	15	15
Cable	702.5 x 2x1.5	702.5 x 2x1.5	702.5 x 2x1.5

Motor Data

	230			380			1320H/M		
	230	230	230	380	380	380	230	230	230
Voltage	230	230	230	380	380	380	230	230	230
Phase	1	1	1	3	3	3	3	1	1
Rated Power (kW)	4.1	5.6	7.5	5.6	4.5	3.5	5.6	4.5	3.5
Rated current (A)	37	34	46.3	32.7	10.9	8.5	35	29	24
Full Load Power Factor	0.85	0.84	0.83	0.82	0.72	0.65	0.85	0.83	0.79
Max. current (A)	118	138	138	82	82	82	107	107	107
Connection	D	-	-	D	D	D	D	-	-

Material Data

Impeller	grey cast iron
Pump housing	grey cast iron
Stator housing	grey cast iron
Shaft	stainless steel
Inner mechanical seal	carbon/cemented carbide
Outer mechanical seal	cemented carbide/cemented carbide
O-rings	nitrile
Cable sheathing	nitrilo

Process Data

Max submergence	20 m
Max fluid temp	40°C
pH range of pumped liquid	5.5 - 14

Power Cable Data

Cable type (mm ²)	702.5 x 2x1.5
Outer Diameter (mm)	22
Weight (kg/m)	0.60

Pump dimensions (mm)

	1320S	1320H	1320M
A	270	392	418
B	425	523	523
C	165	213	213
D	260	310	310
E	151	194	180
F	172	232	214
G	90	117	124

Installation kit selection table*

DN	Free-standing	Wet well	Replacement
80	1320-80H (hose)	1320-80W	1320-80R
100	1320-100H (hose)	1320-100W	1320-100R
100	1320-100H (threaded)		

* For more information, see page 6

3 Select your accessory kit from the relevant accessory selection tables, i.e. installation kit. Please make sure that your configuration corresponds to the right order number and accessory kits and you are ready to order.

Steady® 1305 Non-clog



Performance curves

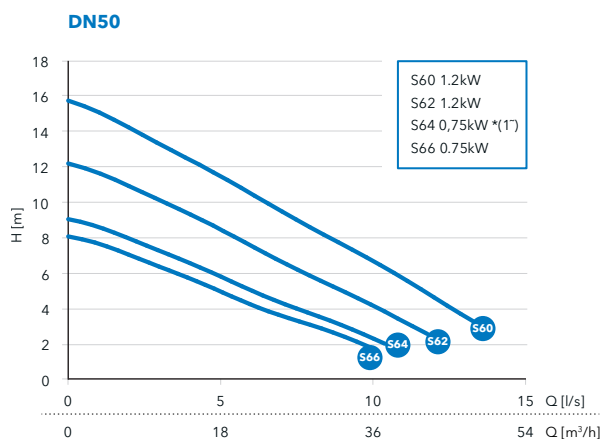

Selection table

Model	DN	Installation*	Pole	Freq (Hz)	Phase	Rated Power	Curve no	Voltage	Cable	Order number**
1305S	50	W, T	2	50	1, 3	[see chart]	S60, S62, S64, S66	230, 400	10	1305S-50-.25-.....-10

* W=Wet well only, T=Free-standing threaded outlet only, X=Bare pump.

** For information on configuring the right order number, see page 7. Pumps come standard with thermal switches.

Pump Data

Model	1305S
Impeller Type	Non-clog
Outlet size (mm)	50
Weight (kg)	30
Pole	2
Insulation Class	F
Starts per hour	15
Cable	4G1.5 + 2x1.5

Motor Data

	1305S		
Voltage	400	400	230
Phase	3	3	1
Rated Power (kW)	1.2	0.75	0.75
Rated current (A)	2.7	2.1	4.1
Full Load Power Factor	0.79	0.63	1.0
Starting current (A)	17	17	19
Connection	Y	Y	-

Material Data

Impeller	grey cast iron
Pump housing	grey cast iron
Stator housing	grey cast iron
Shaft	stainless steel
Inner mechanical seal	carbon/aluminum oxide
Outer mechanical seal	cemented carbide/aluminum oxide
O-rings	nitrile
Cable sheathing	nitrile

Process Data

Max submergence	20 m
Max fluid temp	40 °C
pH range of pumped liquid	5.5 - 14

Power Cable Data

Cable type (mm ²)	4G1.5 + 2x1.5
Outer Diameter (mm)	16
Weight (kg/m)	1

Pump dimensions (mm)

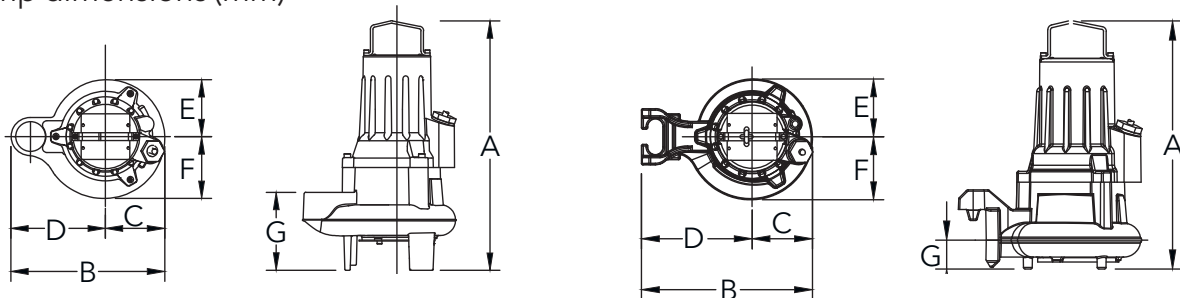

	Free-standing 1305S
A	418
B	298
C	116
D	182
E	97
F	119
G	121

	Wet well 1305S
A	397
B	272
C	116
D	156
E	97
F	120
G	44

Installation kit selection table*

DN	Free-standing	Wet well	Replacement
50	included	1305-50W	included

* For more information, see page 6.

Steady[®] 1305 Vortex



Performance curves

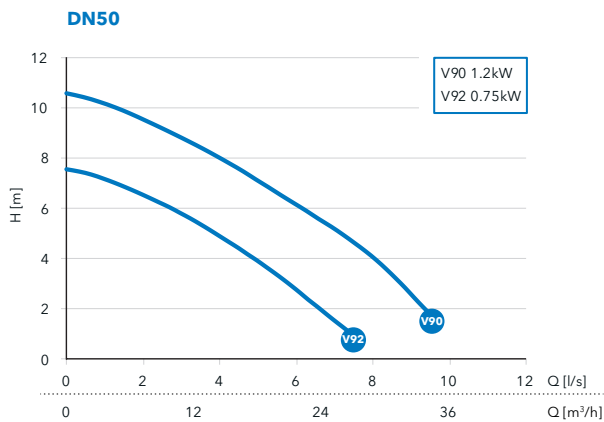

Selection table

Model	DN	Installation*	Pole	Freq (Hz)	Phase	Rated Power	Curve no	Voltage	Cable	Order number**
1305H	50	W, T	2	50	1, 3	[see chart]	V90, V92	230, 400	10	1305H-50-.25-.....-/10

* W=Wet well only, T=Free-standing threaded outlet only.

** For information on configuring the right order number, see page 7. Pumps come standard with thermal switches.

Pump Data

Model	1305H
Impeller Type	Vortex
Outlet size (mm)	50
Weight (kg)	30
Pole	2
Insulation Class	F
Starts per hour	15
Cable	4G1.5 + 2x1.5

Motor Data

	1305H		
Voltage	400	400	230
Phase	3	3	1
Rated Power (kW)	1.2	0.75	0.75
Rated current (A)	2.7	2.1	4.1
Full Load Power Factor	0.79	0.63	1.0
Starting current (A)	17	17	19
Connection	Y	Y	-

Material Data

Impeller	grey cast iron
Pump housing	grey cast iron
Stator housing	grey cast iron
Shaft	stainless steel
Inner mechanical seal	carbon/aluminum oxide
Outer mechanical seal	cemented carbide/aluminum oxide
O-rings	nitrile
Cable sheathing	nitrile

Process Data

Max submergence	20 m
Max fluid temp	40 °C
pH range of pumped liquid	5.5 - 14

Power Cable Data

Cable type (mm ²)	4G1.5 + 2x1.5
Outer Diameter (mm)	16
Weight (kg/m)	0.32

Pump dimensions (mm)

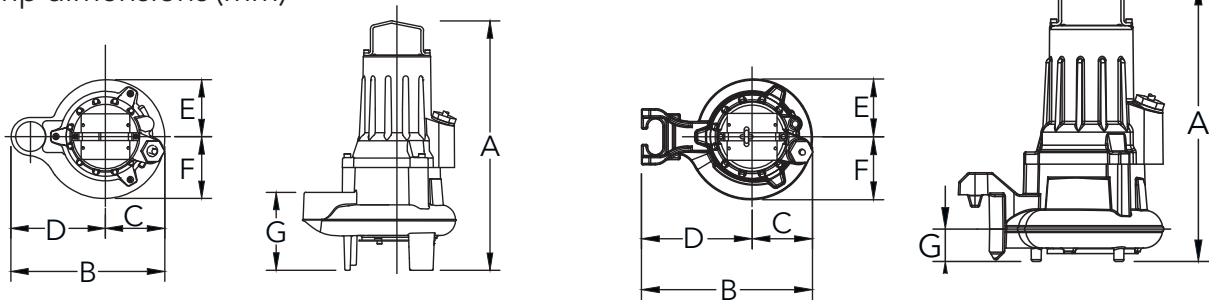

	Free-standing 1305H
A	465
B	299
C	116
D	183
E	103
F	114
G	140

	Wet well 1305H
A	423
B	272
C	116
D	156
E	104
F	114
G	50

Installation kit selection table*

DN	Free-standing	Wet well	Replacement
50	included	1305-50W	included

* For more information, see page 6.

Steady® 1310 Non-clog



Performance curves

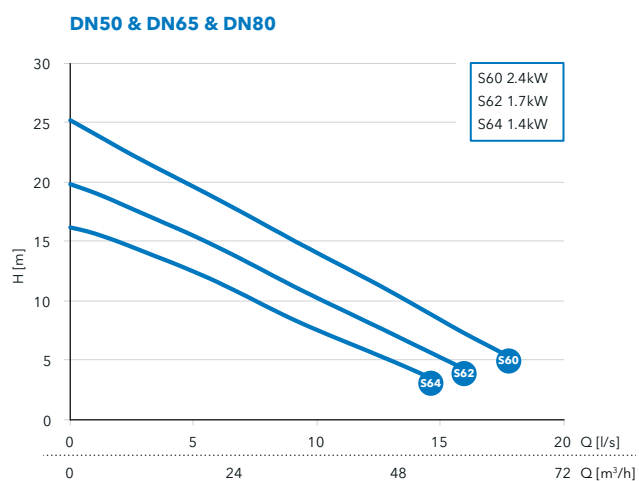

Selection table

Model	DN	Installation*	Pole	Freq (Hz)	Phase	Rated Power	Curve no	Voltage	Cable	Order number**
1310S	50	W, T	2	50	1, 3	[see chart]	S60, S62, S64	230, 400	10	1310S-50-.25-...../10
1310S	65	X	2	50	1, 3	[see chart]	S60, S62, S64	230, 400	10	1310S-65X.25-...../10
1310S	80	X	2	50	1, 3	[see chart]	S60, S62, S64	230, 400	10	1310S-80X.25-...../10

* W=Wet well only, T=Free-standing threaded outlet only, X=Bare pump.

** For information on configuring the right order number, see page 7. Pumps come standard with thermal switches.

Pump Data

Model	1310S
Impeller Type	Non-clog
Outlet size (mm)	50 65 80
Weight (kg)	46
Pole	2
Insulation Class	F
Starts per hour	15
Cable	4G1.5 + 2x1.5

Motor Data

	1310S					
Voltage	400	400	400	230	230	230
Phase	3	3	3	1	1	1
Rated Power (kW)	2.4	1.7	1.4	2.4	1.7	1.4
Rated current (A)	5	3.7	3.3	14.3	9.9	8.3
Full Load Power Factor	0.86	0.79	0.73	0.96	0.95	0.94
Starting current (A)	27	27	27	48	48	48
Connection	Y	Y	Y	-	-	-

Material Data

Impeller	grey cast iron
Pump housing	grey cast iron
Stator housing	grey cast iron
Shaft	stainless steel
Inner mechanical seal	carbon/aluminum oxide
Outer mechanical seal	cemented carbide/aluminum oxide
O-rings	nitrile
Cable sheathing	nitrile

Process Data

Max submergence	20 m
Max fluid temp	40 °C
pH range of pumped liquid	5.5 - 14

Power Cable Data

Cable type (mm ²)	4G1.5 + 2x1.5
Outer Diameter (mm)	16
Weight (kg/m)	0.32

Pump dimensions (mm)

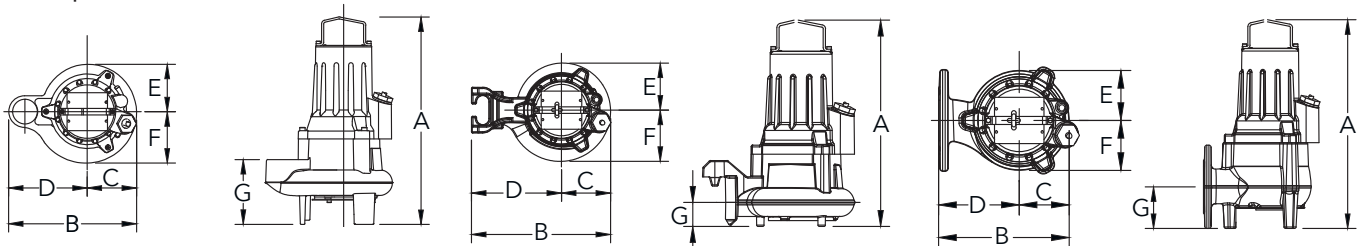

	Free-standing 1310S
A	433
B	304
C	112
D	192
E	103
F	123
G	121

	Wet well 1310S
A	422
B	287
C	112
D	175
E	103
F	123
G	45

	X-installation 1310S
A	457
B	318
C	118
D	200
E	103
F	123
G	100

Installation kit selection table*

DN	Free-standing	Wet well	Replacement
50	included	1310-50W	included
65	1310-65H (hose), 1310-65T (threaded)	1310-65W	1310-65R
80	1310-80H (hose), 1310-80T (threaded)	1310-80W	1310-80R

* For more information, see page 6.

Steady[®] 1310 Vortex



Performance curves

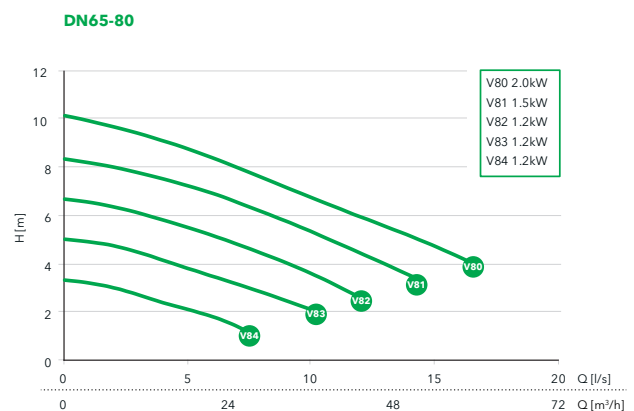
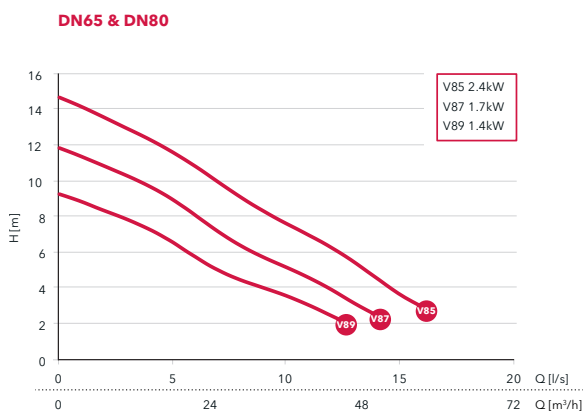
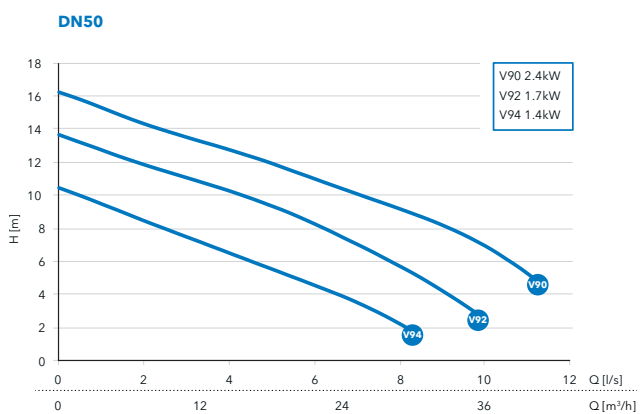

Selection table

Model	DN	Installation*	Pole	Freq (Hz)	Phase	Rated Power	Curve no	Voltage	Cable	Order number**
1310H	50	W, T	2	50	1, 3	[see chart]	V90, V92, V94	230, 400	10	1310H-50-.25-...../10
1310M	65	X	2	50	1, 3	[see chart]	V85, V87, V89	230, 400	10	1310M-65X.25-...../10
1310M	80	X	2	50	1, 3	[see chart]	V85, V87, V89	230, 400	10	1310M-80X.25-...../10
1310L	65-80	X	4	50	1, 3	[see chart]	V80, V81, V82, V83, V84	230, 400	10	1310L-65-80X.45-...../10

* W=Wet well only. T=Free-standing threaded outlet only. X=Bare pump.

** For information on configuring the right order number, see page 7. Pumps come standard with thermal switches.

Pump Data

Model	1310H/M	1310L
Impeller Type	Vortex	Vortex
Outlet size (mm)	50 65 80	65-80
Weight (kg)	46	46
Pole	2	4
Insulation Class	F	F
Starts per hour	15	15
Cable	4G1.5 + 2x1.5	4G1.5 + 2x1.5

Motor Data

	1310H/M					
Voltage	400	400	400	230	230	230
Phase	3	3	3	1	1	1
Rated Power (kW)	2.4	1.7	1.4	2.4	1.7	1.4
Rated current (A)	5	3.7	3.3	14.3	9.9	8.3
Full Load Power Factor	0.86	0.79	0.73	0.96	0.95	0.94
Starting current (A)	27	27	27	48	48	48
Connection	Y	Y	Y	-	-	-

	1310L				
Voltage	400	400	400	230	230
Phase	3	3	3	1	1
Rated Power (kW)	2	1.5	1.2	1.3	1.0
Rated current (A)	4.8	3.8	3.4	8.3	6.5
Full Load Power Factor	0.85	0.77	0.7	1.0	1.0
Starting current (A)	19	19	19	28	28
Connection	Y	Y	Y	-	-

Material Data

Impeller	grey cast iron
Pump housing	grey cast iron
Stator housing	grey cast iron
Shaft	stainless steel
Inner mechanical seal	carbon/aluminum oxide
Outer mechanical seal	cemented carbide/aluminum oxide
O-rings	nitrile
Cable sheathing	nitrile

Process Data

Max submergence	20 m
Max fluid temp	40 °C
pH range of pumped liquid	5.5 - 14

Power Cable Data

Cable type (mm ²)	4G1.5 + 2x1.5
Outer Diameter (mm)	16
Weight (kg/m)	0.32

Pump dimensions (mm)

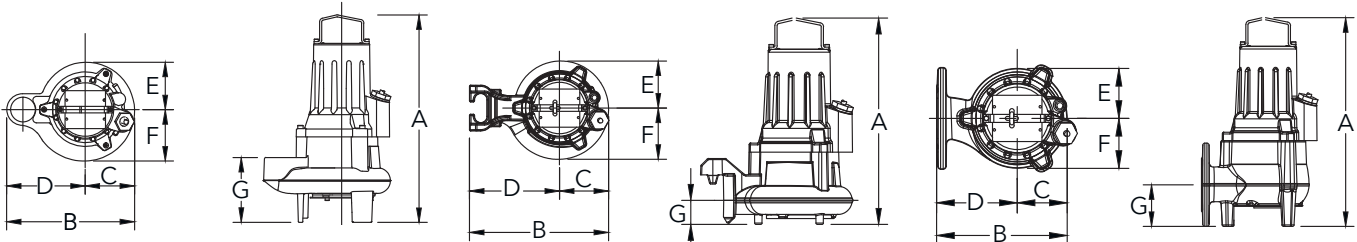

	Free-standing 1310H		Wet well 1310H		X-installation 1310M		1310L	
A		503		455		535		464
B		310		285		259		346
C		120		119		99		146
D		190		166		160		200
E		115		114		106		146
F		125		124		106		146
G		165		53		100		85

Installation kit selection table*

DN	Free-standing	Wet well	Replacement
50	included	1310-50W	Included
65	1310-65H (hose), 1310-65T (threaded)	1310-65W	1310-65R
80	1310-80H (hose), 1310-80T (threaded)	1310-80W	1310-80R

* For more information, see page 6.

Steady[®] 1315 Non-clog



Performance curves

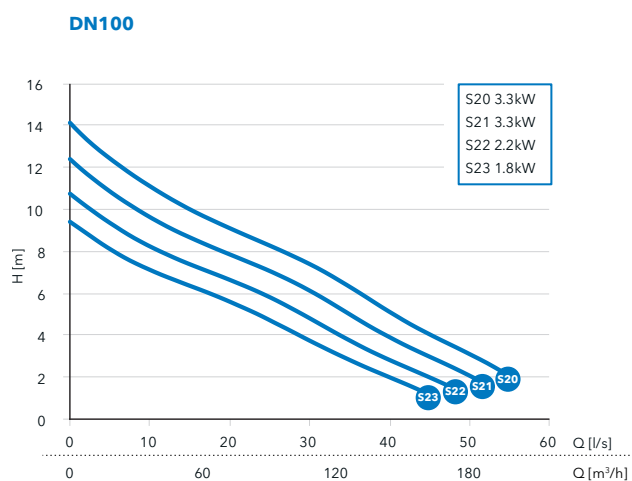
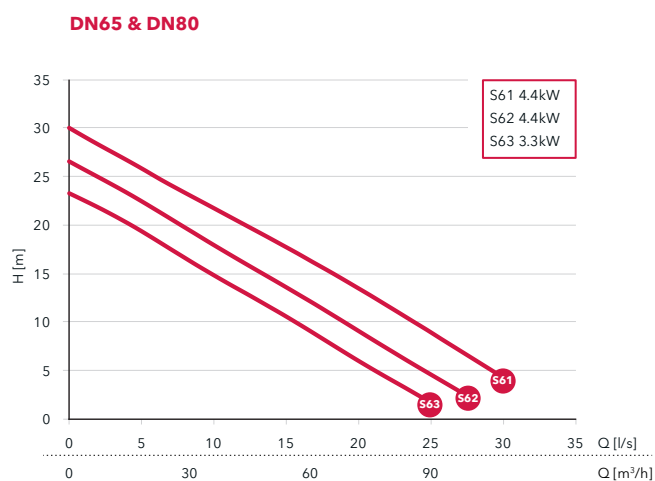

Selection table

Model	DN	Installation*	Pole	Freq (Hz)	Phase	Rated Power	Curve no	Voltage	Cable	Order number**
1315S	65	X	2	50	3	[see chart]	S61, S62, S63	400	10	1315S-65X.253....400/10
1315S	80	X	2	50	3	[see chart]	S61, S62, S63	400	10	1315S-80X.253....400/10
1315M	100	X	4	50	3	[see chart]	S20, S21, S22, S23	400	10	1315M-100X.453....400/10

* X=Bare pump.

** For information on configuring the right order number, see page 7. Pumps come standard with thermal switches.

Pump Data

Model	1315S	1315M
Impeller Type	Non-clog	Non-clog
Outlet size (mm)	80	100
Weight (kg)	95	95
Pole	2	4
Insulation Class	F	F
Starts per hour	15	15
Cable	7G2.5 + 2x1.5	4G1.5 + 2x1.5

Motor Data

	1315S	
Voltage	400	400
Phase	3	3
Rated Power (kW)	4.4	3.3
Rated current (A)	8.5	6.5
Full Load Power Factor	0.9	0.86
Starting current (A)	49	49
Connection	D	D

	1315M		
Voltage	400	400	400
Phase	3	3	3
Rated Power (kW)	3.3	2.2	1.8
Rated current (A)	7.3	5.3	4.8
Full Load Power Factor	0.83	0.73	0.67
Starting current (A)	33	33	33
Connection	Y	Y	Y

Material Data

Impeller	grey cast iron
Pump housing	grey cast iron
Stator housing	grey cast iron
Shaft	stainless steel
Inner mechanical seal	carbon/aluminum oxide
Outer mechanical seal	cemented carbide/aluminum oxide
O-rings	nitrile
Cable sheathing	nitrile

Process Data

Max submergence	20 m
Max fluid temp	40 °C
pH range of pumped liquid	5.5 - 14

Power Cable Data

Cable type (mm ²)	7G2.5 + 2x1.5 4G1.5 + 2x1.5
Outer Diameter (mm)	22 16
Weight (kg/m)	0.60 0.32

Pump dimensions (mm)

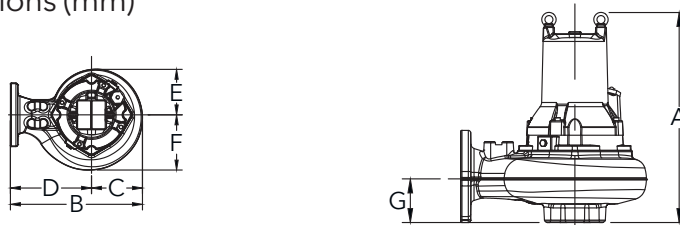

	1315S	1315M
A	508	524
B	377	464
C	147	179
D	230	285
E	146	161
F	148	194
G	90	109

Installation kit selection table*

DN	Free-standing	Wet well	Replacement
65	1315-65H (hose), 1315-65T (threaded)	1315-65W	1315-65R
80	1315-80H (hose), 1315-80T (threaded)	1315-80W	1315-80R
100	1315-100H (hose), 1315-100T (threaded)	1315-100W	1315-100R

* For more information, see page 6.

Steady[®] 1315 Vortex



Performance curves

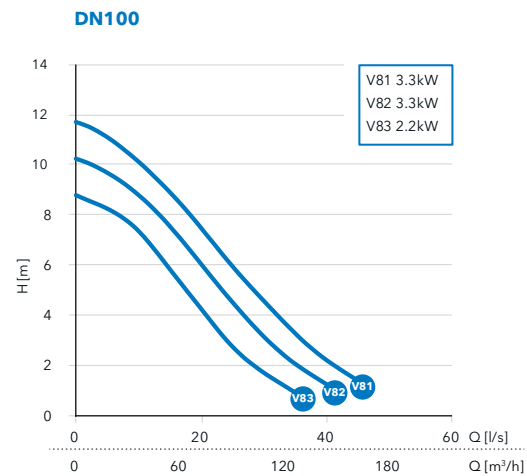
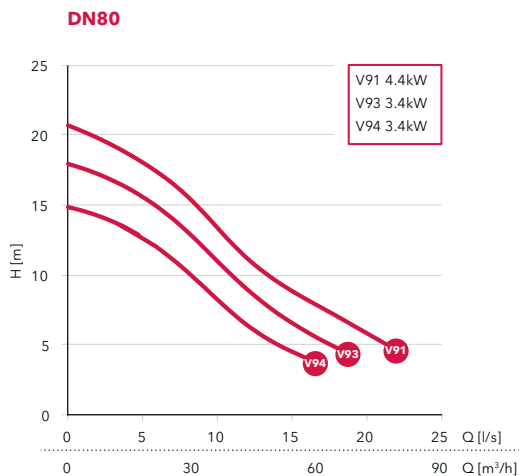

Selection table

Model	DN	Installation*	Pole	Freq (Hz)	Phase	Rated Power	Curve no	Voltage	Cable	Order number**
1315S	80	X	2	50	3	[see chart]	V91, V93, V94	400	10	1315H-80X.253....400/10
1315M	100	X	4	50	3	[see chart]	V81, V82, V83	400	10	1315M-100X.453....400/10

* X=Bare pump.

** For information on configuring the right order number, see page 7. Pumps come standard with thermal switches.

Pump Data

Model	1315H	1315M
Impeller Type	Vortex	Vortex
Outlet size (mm)	65 80	100
Weight (kg)	95	95
Pole	2	4
Insulation Class	F	F
Starts per hour	15	15
Cable	7G2.5 + 2x1.5	4G1.5 + 2x1.5

Motor Data

	1315H	
Voltage	400	400
Phase	3	3
Rated Power (kW)	4.4	3.3
Rated current (A)	8.5	6.5
Full Load Power Factor	0.9	0.86
Starting current (A)	49	49
Connection	D	D

	1315M	
Voltage	400	400
Phase	3	3
Rated Power (kW)	3.3	2.2
Rated current (A)	7.3	5.3
Full Load Power Factor	0.83	0.73
Starting current (A)	33	33
Connection	Y	Y

Material Data

Impeller	grey cast iron
Pump housing	grey cast iron
Stator housing	grey cast iron
Shaft	stainless steel
Inner mechanical seal	carbon/aluminum oxide
Outer mechanical seal	cemented carbide/aluminum oxide
O-rings	nitrile
Cable sheathing	nitrile

Process Data

Max submergence	20 m
Max fluid temp	40 °C
pH range of pumped liquid	5.5 - 14

Power Cable Data

Cable type (mm ²)	7G2.5 + 2x1.5 4G1.5 + 2x1.5
Outer Diameter (mm)	22 16
Weight (kg/m)	0.60 0.32

Pump dimensions (mm)



	1315H	1315M
A	523	573
B	342	367
C	142	142
D	200	225
E	144	148
F	145	147
G	100	120

Installation kit selection table*

DN	Free-standing	Wet well	Replacement
65	1315-65H (hose), 1315-65T (threaded)	1315-65W	1315-65R
80	1315-80H (hose), 1315-80T (threaded)	1315-80W	1315-80R
100	1315-100H (hose), 1315-100T (threaded)	1315-100W	1315-100R

* For more information, see page 6.

Steady® 1320 Non-clog



Performance curves

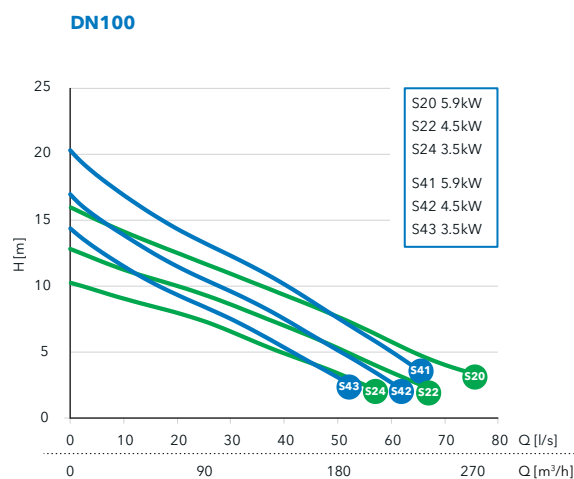
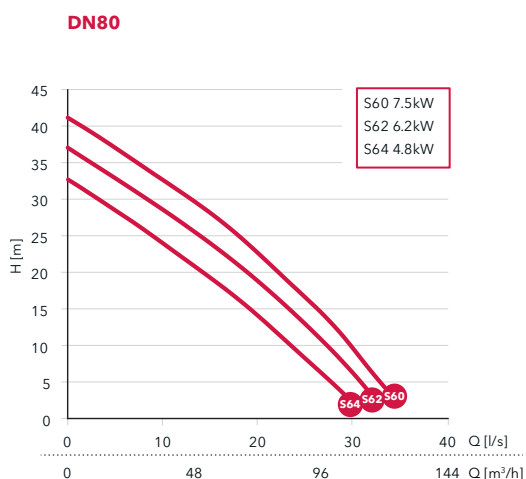

Selection table

Model	DN	Installation*	Pole	Freq (Hz)	Phase	Rated Power	Curve no	Voltage	Cable	Order number**
1320S	80	X	2	50	3	[see chart]	S60, S62, S64	400	10	1320S-80X.253....400/10
1320H	100	X	4	50	3	[see chart]	S41, S42, S43	400	10	1320H-100X.453....400/10
1320M	100	X	4	50	3	[see chart]	S20, S22, S24	400	10	1320M-100X.453....400/10

* X=Bare pump.

** For information on configuring the right order number, see page 7. Pumps come standard with thermal switches.

Pump Data

Model	1320S	1320H	1320M
Impeller Type	Non-clog	Non-clog	Non-clog
Outlet size (mm)	80	100	100
Weight (kg)	130	140	156
Pole	2	4	4
Insulation Class	F	F	F
Starts per hour	15	15	15
Cable	7G2.5 + 2x1.5	7G2.5 + 2x1.5	7G2.5 + 2x1.5

Motor Data

	1320S		
Voltage	400	400	400
Phase	3	3	3
Rated Power (kW)	7.5	6.2	4.8
Rated current (A)	14	11.9	9.7
Full Load Power Factor	0.88	0.85	0.8
Starting current (A)	107	107	107
Connection	YD	YD	YD

	1320H/M		
Voltage	400	400	400
Phase	3	3	3
Rated Power (kW)	5.9	4.5	3.5
Rated current (A)	12.5	9.9	8.4
Full Load Power Factor	0.82	0.77	0.7
Starting current (A)	60	60	60
Connection	YD	YD	YD

Material Data

Impeller	grey cast iron
Pump housing	grey cast iron
Stator housing	grey cast iron
Shaft	stainless steel
Inner mechanical seal	carbon/cemented carbide
Outer mechanical seal	cemented carbide/cemented carbide
O-rings	nitrile
Cable sheathing	nitrile

Process Data

Max submergence	20 m
Max fluid temp	40 °C
pH range of pumped liquid	5.5 - 14

Power Cable Data

Cable type (mm ²)	7G2.5 + 2x1.5
Outer Diameter (mm)	22
Weight (kg/m)	0.60

Pump dimensions (mm)

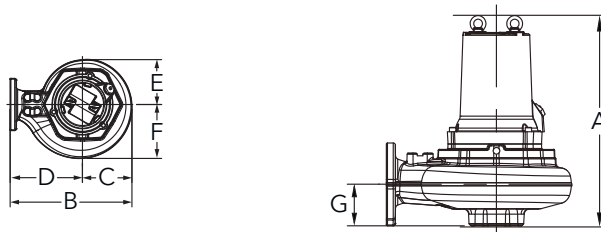

	1320S	1320H	1320M
A	570	592	618
B	425	523	523
C	165	213	213
D	260	310	310
E	151	194	180
F	172	232	214
G	90	117	124

Installation kit selection table*

DN	Free-standing	Wet well	Replacement
80	1320-80H (hose), 1320-80T (threaded)	1320-80W	1320-80R
100	1320-100H (hose), 1320-100T (threaded)	1320-100W	1320-100R

* For more information, see page 6.

Steady[®] 1320 Vortex



Performance curves

DN80

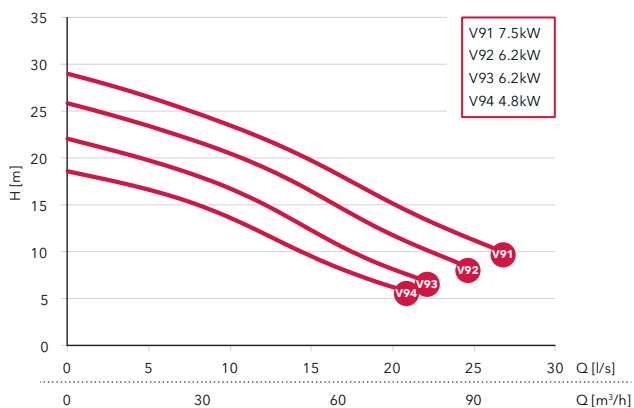

DN100

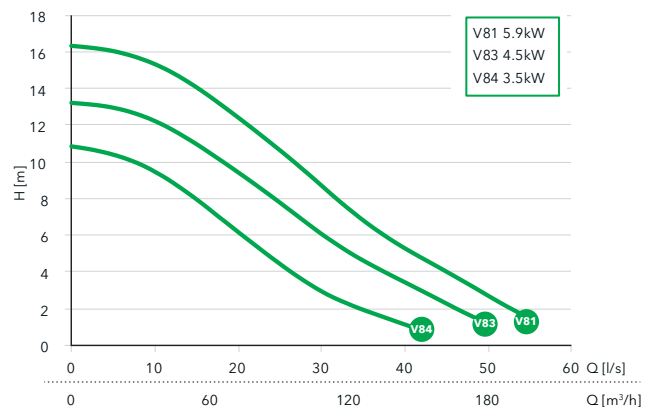

Selection table

Model	DN	Installation*	Pole	Freq (Hz)	Phase	Rated Power	Curve no	Voltage	Cable	Order number**
1320H	80	X	2	50	3	[see chart]	V91, V92, V93, V94	400	10	1320H-80X.253....400/10
1320M	100	X	4	50	3	[see chart]	V81, V83, V84	400	10	1320M-100X.453....400/10

* X=Bare pump.

** For information on configuring the right order number, see page 7. Pumps come standard with thermal switches.

Pump Data

Model	1320H	1320M
Impeller Type	Vortex	Vortex
Outlet size (mm)	80	100
Weight (kg)	140	156
Pole	2	4
Insulation Class	F	F
Starts per hour	15	15
Cable	7G2.5 + 2x1.5	7G2.5 + 2x1.5

Motor Data

	1320H		
Voltage	400	400	400
Phase	3	3	3
Rated Power (kW)	7.5	6.2	4.8
Rated current (A)	14	11.9	9.7
Full Load Power Factor	0.88	0.85	0.8
Starting current (A)	107	107	107
Connection	YD	YD	YD

	1320M		
Voltage	400	400	400
Phase	3	3	3
Rated Power (kW)	5.9	4.5	3.5
Rated current (A)	12.5	9.9	8.4
Full Load Power Factor	0.82	0.77	0.7
Starting current (A)	60	60	60
Connection	YD	YD	YD

Material Data

Impeller	grey cast iron
Pump housing	grey cast iron
Stator housing	grey cast iron
Shaft	stainless steel
Inner mechanical seal	carbon/cemented carbide
Outer mechanical seal	cemented carbide/cemented carbide
O-rings	nitrile
Cable sheathing	nitrile

Process Data

Max submergence	20 m
Max fluid temp	40 °C
pH range of pumped liquid	5.5 - 14

Power Cable Data

Cable type (mm ²)	7G2.5 + 2x1.5
Outer Diameter (mm)	22
Weight (kg/m)	0.60

Pump dimensions (mm)



	1320H	1320M
A	610	674
B	375	419
C	165	174
D	210	245
E	154	166
F	154	167
G	100	123

Installation kit selection table*

DN	Free-standing	Wet well	Replacement
80	1320-80H (hose), 1320-80T (threaded)	1320-80W	1320-80R
100	1320-100H (hose), 1320-100T (threaded)	1320-100W	1320-100R

* For more information, see page 6.

Steady® 1325 Non-clog



Performance curves

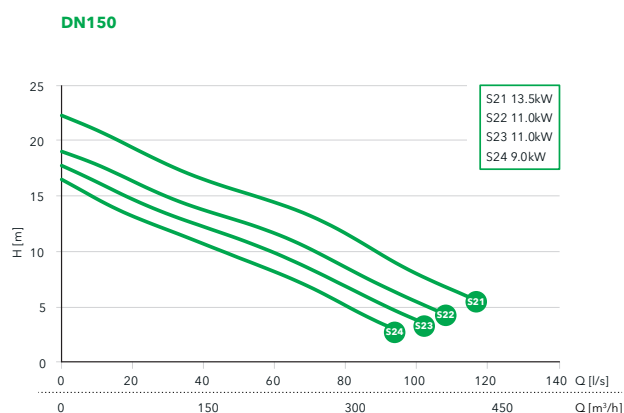
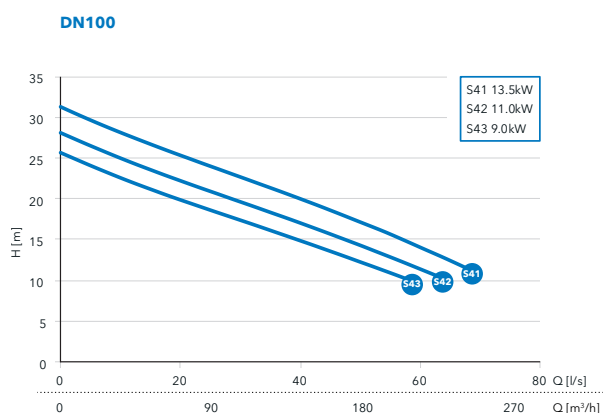
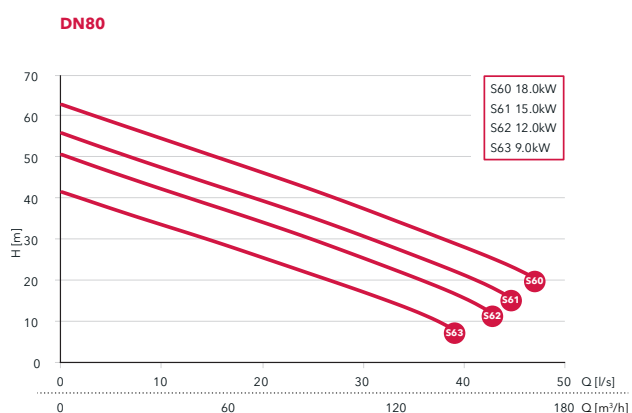

Selection table

Model	DN	Installation*	Pole	Freq (Hz)	Phase	Rated Power	Curve no	Voltage	Cable	Order number**
1325S	80	X	2	50	3	[see chart]	S60, S61, S62, S63	400	10	1325S-80X.253....400/10
1325H	100	X	4	50	3	[see chart]	S41, S42, S43	400	10	1325H-100X.453....400/10
1325M	150	X	4	50	3	[see chart]	S21, S22, S23, S24	400	10	1325M-150X.453....400/10

* X=Bare pump.

** For information on configuring the right order number, see page 7. Pumps come standard with thermal switches.

Pump Data

Model	1325S	1325H	1325M
Impeller Type	Non-clog	Non-clog	Non-clog
Outlet size (mm)	80	100	150
Weight (kg)	170	180	190
Pole	2	4	4
Insulation Class	F	F	F
Starts per hour	15	15	15
Cable	7G2.5 + 2x1.5	7G2.5 + 2x1.5	7G2.5 + 2x1.5

Motor Data

	1325S			
Voltage	400	400	400	400
Phase	3	3	3	3
Rated Power (kW)	18	15	12	9
Rated current (A)	32	27	22	17.9
Full Load Power Factor	0.9	0.89	0.86	0.8
Starting current (A)	213	213	213	213
Connection	YD	YD	YD	YD

	1325H/M		
Voltage	400	400	400
Phase	3	3	3
Rated Power (kW)	13.5	11	9
Rated current (A)	27	23	19.8
Full Load Power Factor	0.82	0.79	0.74
Starting current (A)	145	145	145
Connection	YD	YD	YD

Material Data

Impeller	grey cast iron
Pump housing	grey cast iron
Stator housing	grey cast iron
Shaft	stainless steel
Inner mechanical seal	carbon/cemented carbide
Outer mechanical seal	cemented carbide/cemented carbide
O-rings	nitrile
Cable sheathing	nitrile

Process Data

Max submergence	20 m
Max fluid temp	40 °C
pH range of pumped liquid	5.5 - 14

Power Cable Data

Cable type (mm ²)	7G2.5 + 2x1.5
Outer Diameter (mm)	22
Weight (kg/m)	0.60

Pump dimensions (mm)

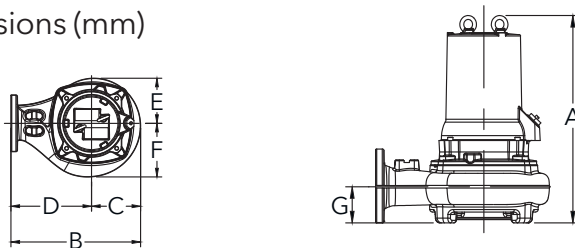

	1325S	1325H	1325M
A	650	667	663
B	505	531	550
C	175	201	220
D	330	330	330
E	175	185	187
F	175	220	259
G	82	110	137

Installation kit selection table*

DN	Free-standing	Wet well	Replacement
80	13205-80H (hose), 1325-80T (threaded)	1325-80W	1325-80R
100	1325-100H (hose), 1325-100T (threaded)	1325-100W	1325-100R
150	1325-150H (hose), 1325-150T (threaded)	1325-150W	1325-150R

* For more information, see page 6.

Steady[®] 1330 Non-clog



Performance curves

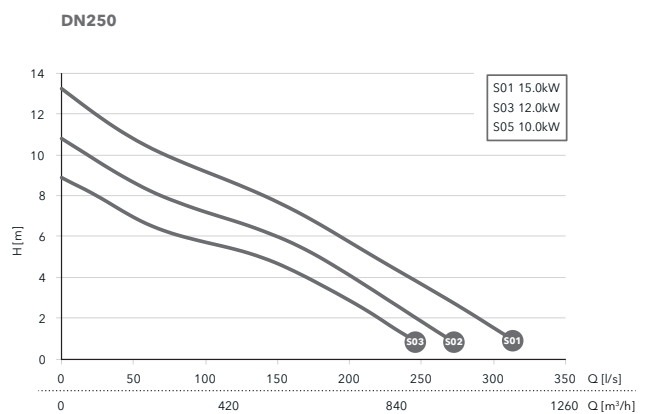
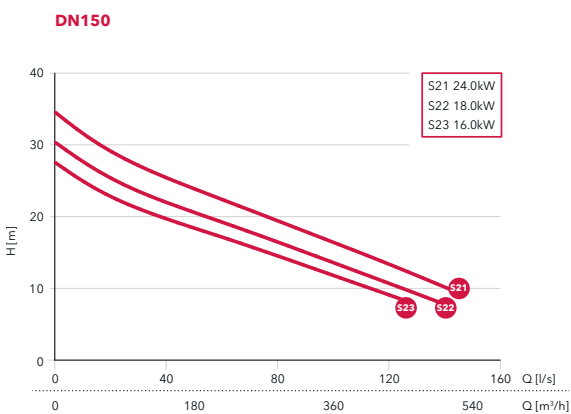
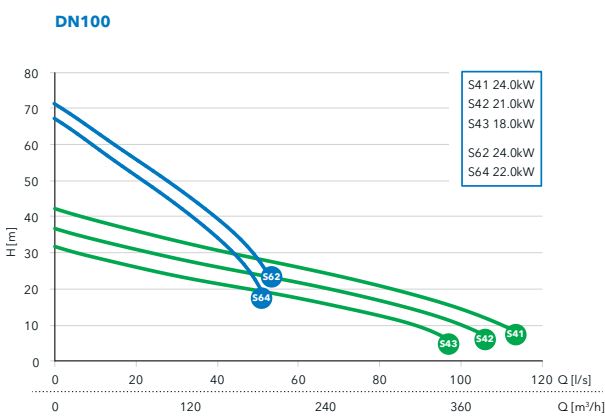

Selection table

Model	DN	Installation*	Pole	Freq (Hz)	Phase	Rated Power	Curve no	Voltage	Cable	Order number**
1330S	100	X	2	50	3	[see chart]	S62, S64	400	10	1330S-100X.253....400/10
1330H	100	X	4	50	3	[see chart]	S41, S42, S43	400	10	1330H-100X.453....400/10
1330M	150	X	4	50	3	[see chart]	S21, S22, S23	400	10	1330M-150X.453....400/10
1330L	250	X	6	50	3	[see chart]	S01, S03, S05	400	10	1330L-250X.653....400/10

* X=Bare pump.

** For information on configuring the right order number, see page 7. Pumps come standard with thermal switches.

Pump Data

Model	1330S	1330H	1330M	1330L
Impeller Type	Non-clog	Non-clog	Non-clog	Non-clog
Outlet size (mm)	100	100	150	250
Weight (kg)	300	300	314	420
Pole	2	4	4	6
Insulation Class	F	F	F	F
Starts per hour	15	15	15	15
Cable	4G6 + 2x1.5	4G6 + 2x1.5	4G6 + 2x1.5	4G4 + 2x1.5

Motor Data

	1330S		1330H/M				1330L		
Voltage	400	400	400	400	400	400	400	400	
Phase	3	3	3	3	3	3	3	3	
Rated Power (kW)	24	22	24	21	18	16	15	12	
Rated current (A)	42	38	45	39	34	31	30	25	
Full Load Power Factor	0.93	0.93	0.88	0.87	0.85	0.83	0.85	0.81	
Starting current (A)	269	269	251	251	251	251	166	166	
Connection	D	D	D	D	D	D	D	D	

Material Data

Impeller	grey cast iron
Pump housing	grey cast iron
Stator housing	grey cast iron
Shaft	stainless steel
Inner mechanical seal	cemented carbide/cemented carbide
Outer mechanical seal	cemented carbide/cemented carbide
O-rings	nitrile
Cable sheathing	nitrile

Process Data

Max submergence	20 m
Max fluid temp	40 °C
pH range of pumped liquid	5.5 - 14

Power Cable Data

Cable type (mm ²)	4G6 + 2x1.5 4G4 + 2x1.5
Outer Diameter (mm)	26 22
Weight (kg/m)	0.83 0.63

Pump dimensions (mm)

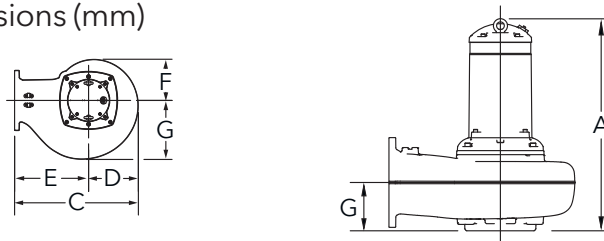

	1330S	1330H	1330M	1330L
A	785	813	845	952
B	564	596	633	837
C	204	236	253	337
D	360	360	380	500
E	204	220	224	278
F	204	255	284	399
G	82	115	137	217

Installation kit selection table*

DN	Wet well	Replacement
100	1330-100W	1330-100R
150	1330-150W	1330-150R
250	1330-250W	1330-250R

* For more information, see page 6.

Steady® 1335 Non-clog



Performance curves

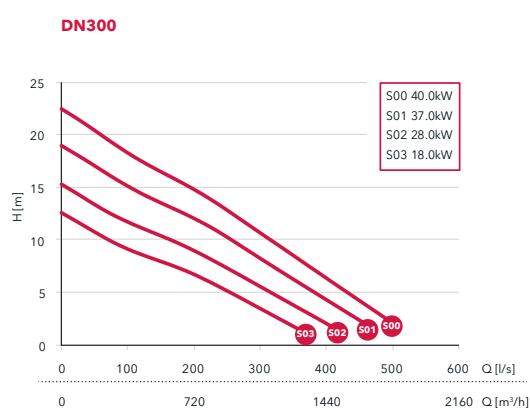
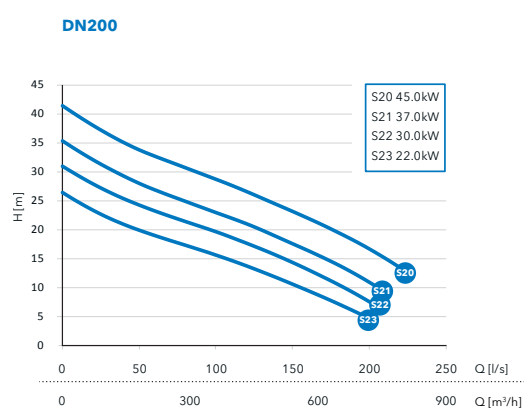
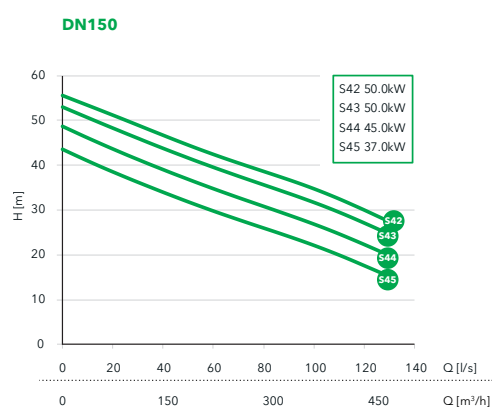

Selection table

Model	DN	Installation*	Pole	Freq (Hz)	Phase	Rated Power	Curve no	Voltage	Cable	Order number**
1335H	150	X	4	50	3	[see chart]	S42, S43, S44, S45	400	10	1335H-150X.453....400/10
1335M	200	X	4	50	3	[see chart]	S20, S21, S22, S23	400	10	1335M-200X.453....400/10
1335L	300	X	6	50	3	[see chart]	S00, S01, S02, S03	400	10	1335L-300X.653....400/10

* X=Bare pump.

** For information on configuring the right order number, see page 7. Pumps come standard with thermal switches.

Pump Data

Model	1335H	1335M	1335L
Impeller Type	Non-clog	Non-clog	Non-clog
Outlet size (mm)	150	200	300
Weight (kg)	580	580	760
Pole	4	4	6
Insulation Class	F	F	F
Starts per hour	15	15	15
Cable	4G16 + S(2x0.5)	4G16 + S(2x0.5)	4G16 + S(2x0.5)

Motor Data

	1335H/M				
Voltage	400	400	400	400	400
Phase	3	3	3	3	3
Rated Power (kW)	50	45	37	30	22
Rated current (A)	87	79	66	55	44
Full Load Power Factor	0.9	0.9	0.88	0.85	0.78
Starting current (A)	540	540	540	540	540
Connection	D	D	D	D	D

	1335L				
Voltage	400	400	400	400	400
Phase	3	3	3	3	3
Rated Power (kW)	40	37	28	21	18
Rated current (A)	76	71	56	46	43
Full Load Power Factor	0.85	0.84	0.79	0.72	0.67
Starting current (A)	415	415	415	415	415
Connection	D	D	D	D	D

Material Data

Impeller	grey cast iron
Pump housing	grey cast iron
Stator housing	grey cast iron
Shaft	stainless steel
Inner mechanical seal	cemented carbide/cemented carbide
Outer mechanical seal	cemented carbide/cemented carbide
O-rings	nitrile
Cable sheathing	nitrile

Process Data

Max submergence	20 m
Max fluid temp	40 °C
pH range of pumped liquid	5.5 - 14

Power Cable Data

Cable type (mm ²)	4G16 + S(2x0.5)
Outer Diameter (mm)	28
Weight (kg/m)	1.30

Pump dimensions (mm)

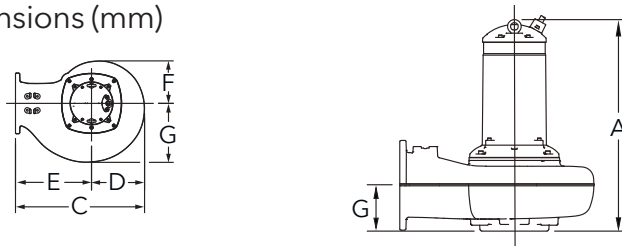

	1335H	1335M	1335L
A	988	997	1108
B	733	803	1018
C	283	303	418
D	450	500	600
E	263	267	335
F	306	342	465
G	150	168	243

Installation kit selection table*

DN	Wet well	Replacement
150	1335-150W	1335-150R
200	1335-200W	1335-200R
300	1335-300W	1335-300R

* For more information, see page 6.

Right pump for your needs



Steady 1305 Non-clog

- Maximum flow 14 l/s
- Maximum pressure 17 m
- Motor Rating 0.75 - 1.2 kW
- Outlet 50 mm
- Weight 30 kg



Steady 1305 Vortex

- Maximum flow 10 l/s
- Maximum pressure 11 m
- Motor Rating 0.75 - 1.2 kW
- Outlet 50 mm
- Weight 30 kg



Steady 1310 Non-clog

- Maximum flow 18 l/s
- Maximum pressure 25 m
- Motor Rating 1.4 - 2.4 kW
- Outlet 50 - 80 mm
- Weight 46 kg



Steady 1310 Vortex

- Maximum flow 16 l/s
- Maximum pressure 16 m
- Motor Rating 1.2 - 2.4 kW
- Outlet 50 - 80 mm
- Weight 46 kg



Steady 1315 Non-clog

- Maximum flow 54 l/s
- Maximum pressure 30 m
- Motor Rating 1.8 - 4.4 kW
- Outlet 80 - 100 mm
- Weight 95 kg



Steady 1315 Vortex

- Maximum flow 44 l/s
- Maximum pressure 15 m
- Motor Rating 2.2 - 4.4 kW
- Outlet 65 - 100 mm
- Weight 95 kg



Steady 1320 Non-clog

- Maximum flow 74 l/s
- Maximum pressure 41 m
- Motor Rating 3.5 - 7.5 kW
- Outlet 80 - 100 mm
- Weight 130 - 156 kg



Steady 1320 Vortex

- Maximum flow 54 l/s
- Maximum pressure 29 m
- Motor Rating 3.5 - 7.5 kW
- Outlet 80 - 100 mm
- Weight 140 - 156 kg



Steady 1325 Non-clog

- Maximum flow 115 l/s
- Maximum pressure 63 m
- Motor Rating 9 - 18 kW
- Outlet 80 - 150 mm
- Weight 170 - 190 kg



Steady 1330 Non-clog

- Maximum flow 310 l/s
- Maximum pressure 74 m
- Motor Rating 10 - 24 kW
- Outlet 100 - 250 mm
- Weight 300 - 420 kg



Steady 1335 Non-clog

- Maximum flow 492 l/s
- Maximum pressure 55 m
- Motor Rating 18 - 50 kW
- Outlet 150 - 300 mm
- Weight 580 - 760 kg



Xylem |'zīləm|

- 1) The tissue in plants that brings water upward from the roots;
- 2) A leading global water technology company.

We're 12,900 people unified in a common purpose: creating innovative solutions to meet our world's water needs. Developing new technologies that will improve the way water is used, conserved, and re-used in the future is central to our work. We move, treat, analyze, and return water to the environment, and we help people use water efficiently, in their homes, buildings, factories and farms. In more than 150 countries, we have strong, long-standing relationships with customers who know us for our powerful combination of leading product brands and applications expertise, backed by a legacy of innovation.

For more information on how Xylem can help you, go to www.xyleminc.com

Singapore (Regional Head Office)

Xylem Water Solutions Singapore Pte Ltd.
6 Wan Lee Road
Singapore 627937
Tel: +65.6507.6999

Korea

Xylem Water Solutions Korea Co., Ltd.
#905-906, Daeryung Techno Town 15cha
Gwanyang-dong, Dongan-gu
Anyang-si, Gyeonggi-do, 432-060
Tel: +82.31.389.5710

Japan

Xylem Water Systems Japan Corporation
13F PARALE Mitsui Building, 8 Higashidacho
Kawasaki-Ku, Kawasaki-City, Kanagawa 210-0005
Tel: +81.44.272.5222

Vietnam

Xylem Water Solutions Hong Kong Ltd.
Unit 10-04, 10/F, GELEX Tower
52 Le Dai Hanh Street, Hai Ba Trung District, Hanoi
Tel: +844.3974.7766

asia@xyleminc.com

Philippines

Xylem Water Systems International, Inc.
12 Ring Road, LISP II, Calamba Laguna 4027
Tel: +63.49.543.4300

Thailand

Xylem Water Systems International, Inc.
16F, Unit A, Bangna Tower A, 2/3 Moo 14
Bangna - Trad Road, KM. 6.5 Bangkaew
Bangplee, Samutprakam 10540
Tel: +66.2797.0718

Indonesia

Xylem Water Solutions Singapore Pte Ltd.
32/F Tempo Scan Tower, Jl. HR Rasuna Said Kav. 3-4
Jakarta 12950
Tel: +62.21.2934.9492

Hong Kong

Xylem Water Solutions Hong Kong Ltd.
Unit 12-16, 17/F, Grand City Plaza
1-17 Sai Lau Kok Road, Tsuen Wan, N.T.
Tel: +852.2945.0100

Malaysia

Xylem Water Solutions Malaysia Sdn. Bhd.
Lot 59, Jl. Tanjung Medan 26/12, Shah Alam
40000 Selangor
Tel: +603.5102.6888

asia.xylem.com