



GIS/ GISO Series End Suction Pumps

TECHNICAL BULLETIN



ISO End Suction Centrifugal Pump - Technical Sales Data

Goulds Water Technology is renowned for manufacturing the highest quality pumping equipment utilizing the best engineering practices available worldwide. The GISO / GIS series back pull out, foot mounted centrifugal is no exception. The single stage end suction pump has been designed with latest CAD (Computer Aided Design) and CFD (Computational Fluid Dynamics) and is accordance with the international standard ISO 2858. This highly efficient and flexible design makes the GISO / GIS series pump ideal for wide range of pumping applications, from water supply and irrigation to mining and building services.

Design Versions

The pump comes in two designs: "GISO" long coupled (frame mount) series is suitable for belt driven motors and "GIS" close coupled (stub shaft) series is suitable for direct attachment to 2 or 4 pole IEC frame motors. The standard horizontal configuration units have a vertical centerline discharge; however these models can also be mounted in a variety of different positions including horizontal discharge, with or without vertical mounting of the pump bearing housing.

Pumped Liquid

Designed for non-combustible, low viscosity liquids, free of solids, abrasive materials and fibres. Various liquid chemical compositions are capable of being pumped through the use of a variety of construction materials and seal options (Refer to materials listed below).

Construction Material

The GISO / GIS series comes with cast iron casing wet end, SS304 impeller and wear rings and SS420 shaft as standard. In order to suit a wider range of applications, the GISO / GIS series of pump casing are also available in the following materials:

- EN-GJL-250 (Cast Iron)
- EN-GJS-450-10 (Ductile Iron)
- EN 1.4301 / AISI 304 (Stainless Steel 304)
- EN 1.4401 / AISI 316 (Stainless Steel 316)
- EN 1.4462 / UNS S32205 (Duplex 2205)

Shaft

Enlarged shaft to minimize deflection with tapered shaft keyed design ensuring positive locking when in operation and ease of impeller removal whilst servicing. Optional shaft materials are available upon request.

Shaft Sealing

Wide ranges of sealing solutions are available for the GISO / GIS series. The standard seal consists of graphite rotating face and ceramic stationary face with fluorine elastomers. For hot or abrasive applications, please contact your authorized Goulds Water Technology distributor.

Bearing Housing & Bearings

Features incorporated into the design of the GISO / GIS bearing housing makes it robust, reliable and easy to service. Standard features include a removable bearing cap on the non-drive end and lip seals fitted to both drive and non-drive ends in order to minimize the ingress of foreign liquids and materials. Bearings are heavy duty bearings with pre-packed grease. Alternative bearing manufacturers and lubrication methods are available upon request. The close coupled version has a heavy-duty cast iron motor adaptor and robust drive shaft clamp for positive motor alignment and stability.

Operating Conditions

Flowrate	:	Max. 2100 m ³ /hr
Pump Head	:	Max. 160 meters
Liquid Temp	:	-15°C to 120°C (Standard Version)
Max Working Pressure	:	160 meters

Please note that Goulds Water Technology, in the interest of product development, may alter technical specifications without notice.

ISO End Suction Centrifugal Pump - 50HZ Performance Range

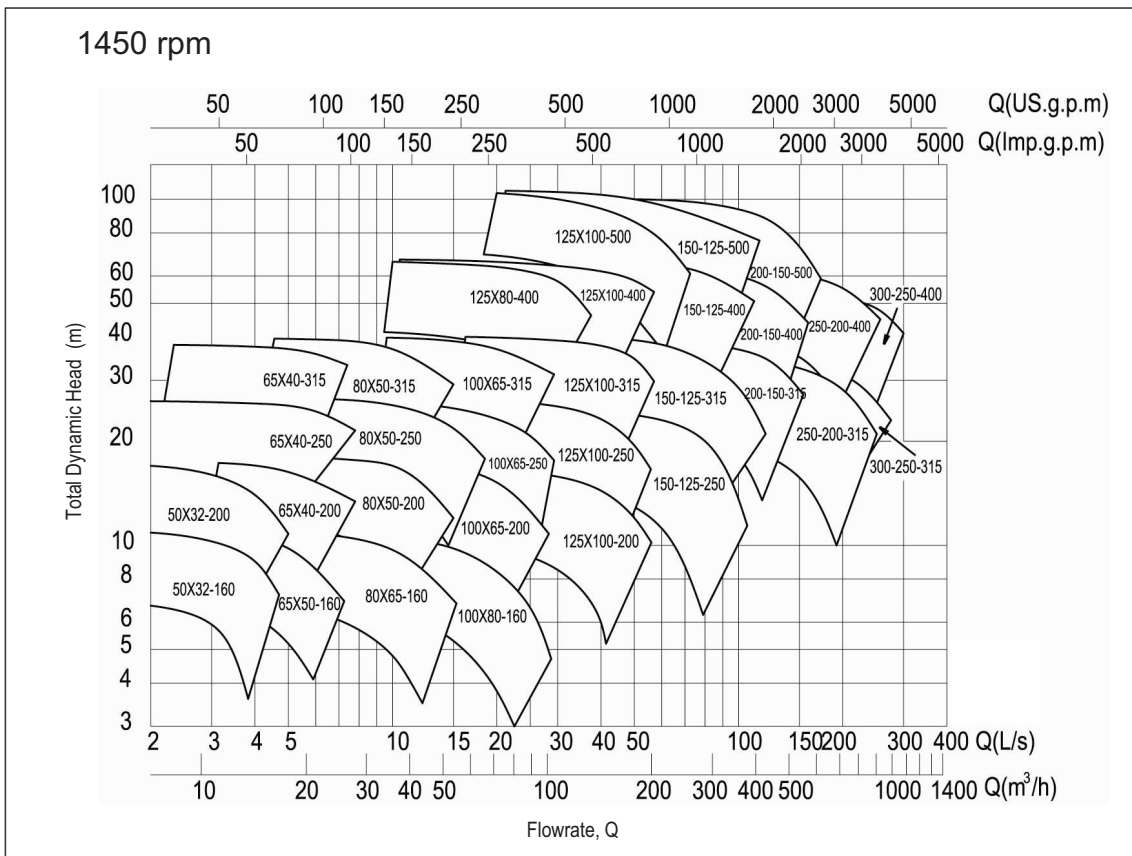
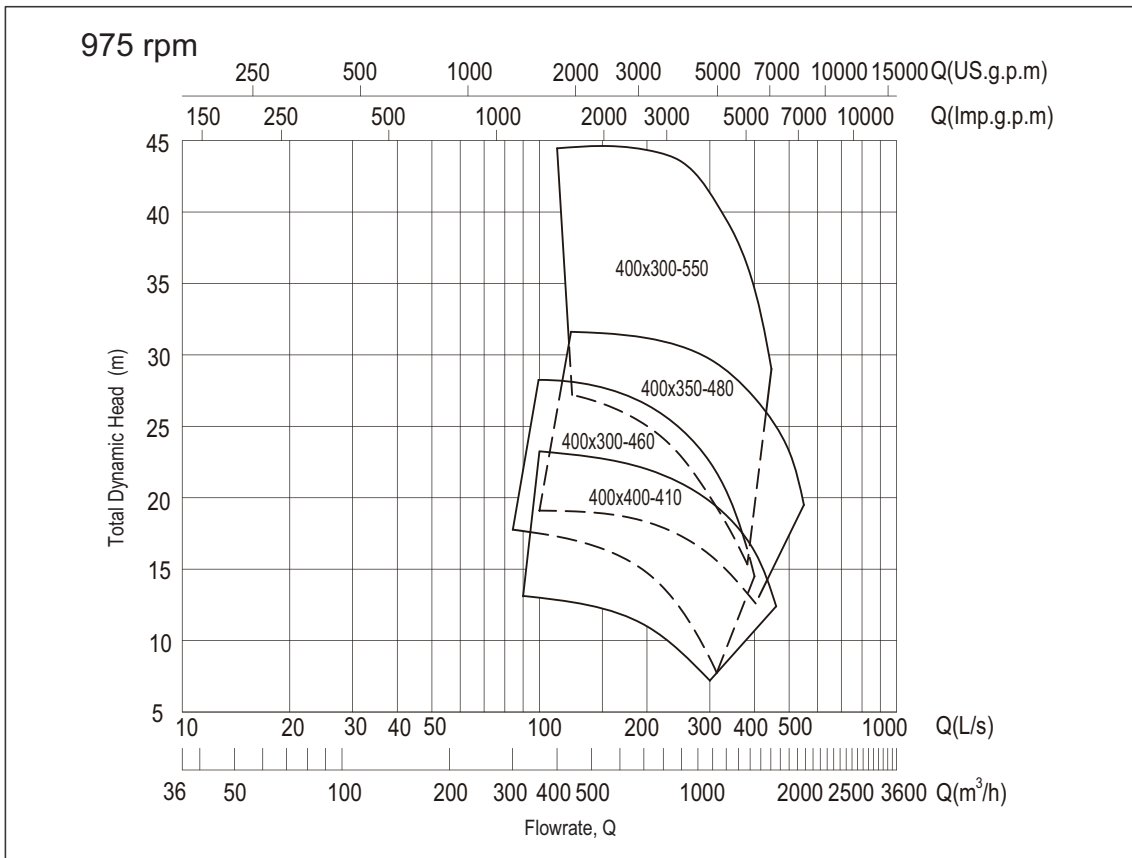

ISO End Suction Centrifugal Pump - 50HZ Performance Range

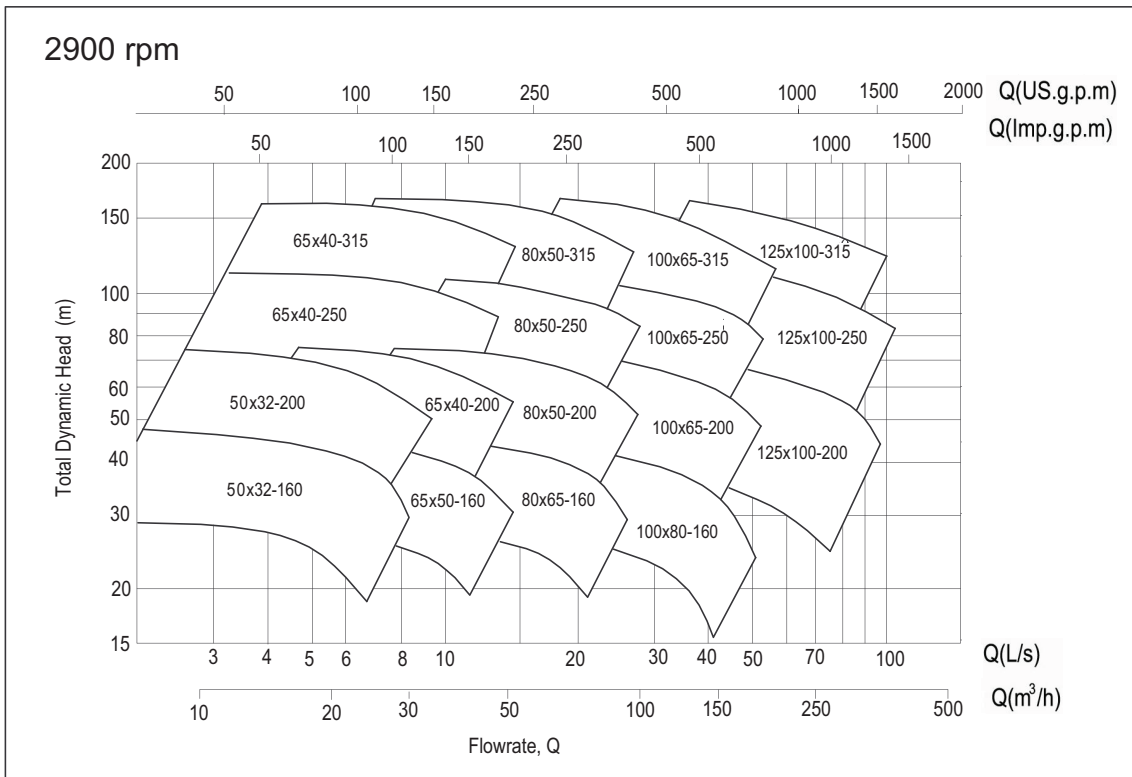

ISO End Suction Centrifugal Pump - Numbering System

Model Description

GIS 50 x 32 -160 - 3 / 2

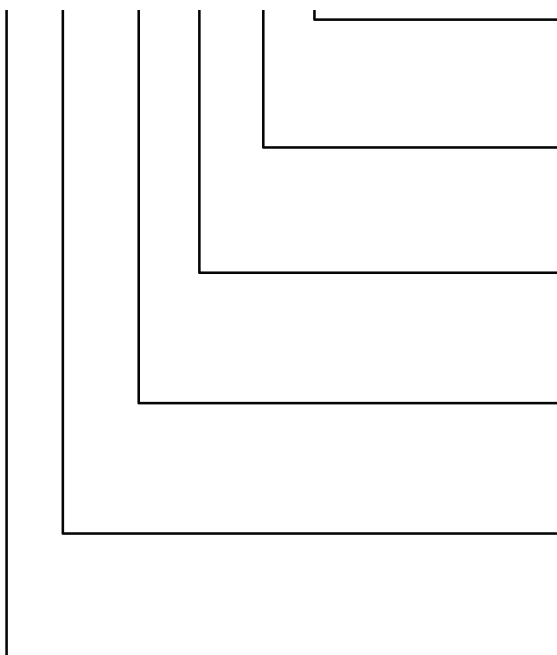

Motor Poles

For example: 2 = 2P

Motor rated power (kW)

For example: 3 = 3kW

Impeller nominal diameter (mm)

For example: 160 = 1 60 mm

Pump discharge diameter (mm)

For example: 32 = DN 32

Pump suction diameter (mm)

For example: 50 = DN50

GISO = Long Coupled (Frame Mount)

GIS = Close Coupled (Stub Shaft)

ISO End Suction Centrifugal Pump - 50x32-160 Performance Curve

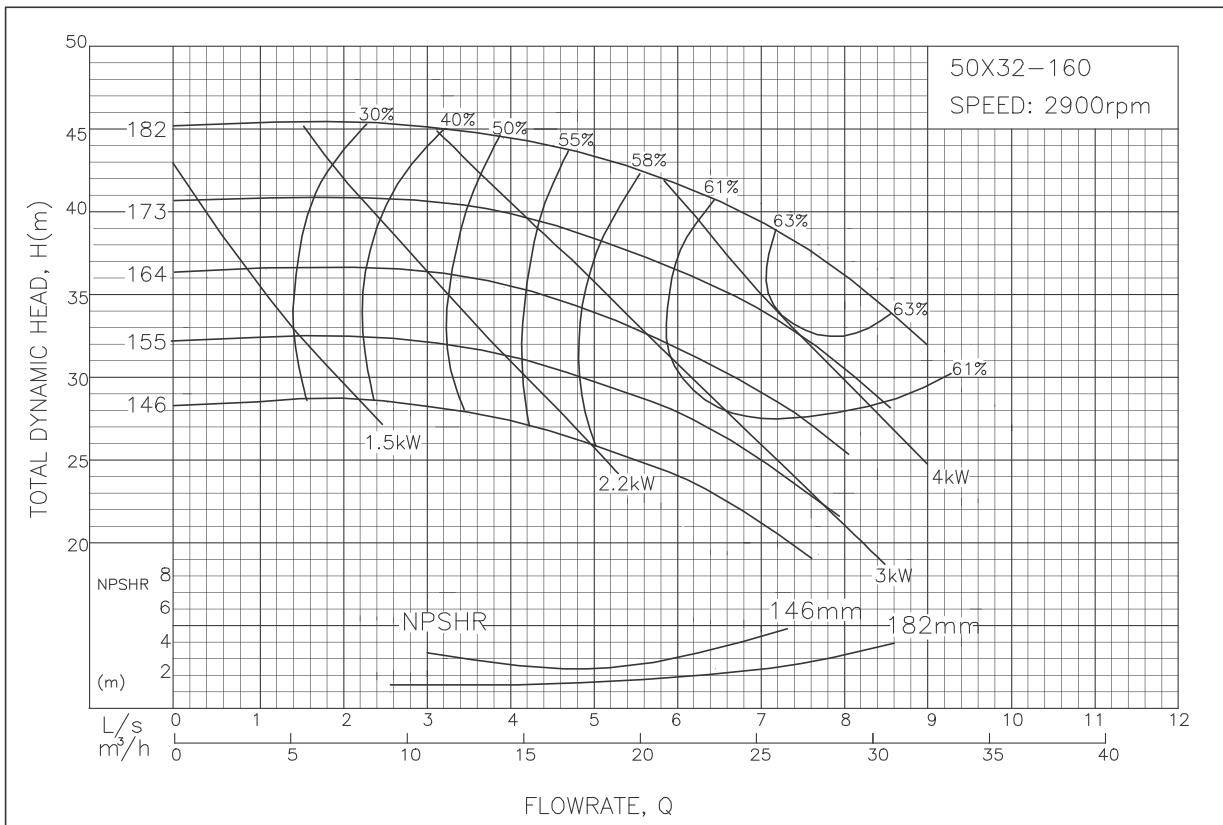
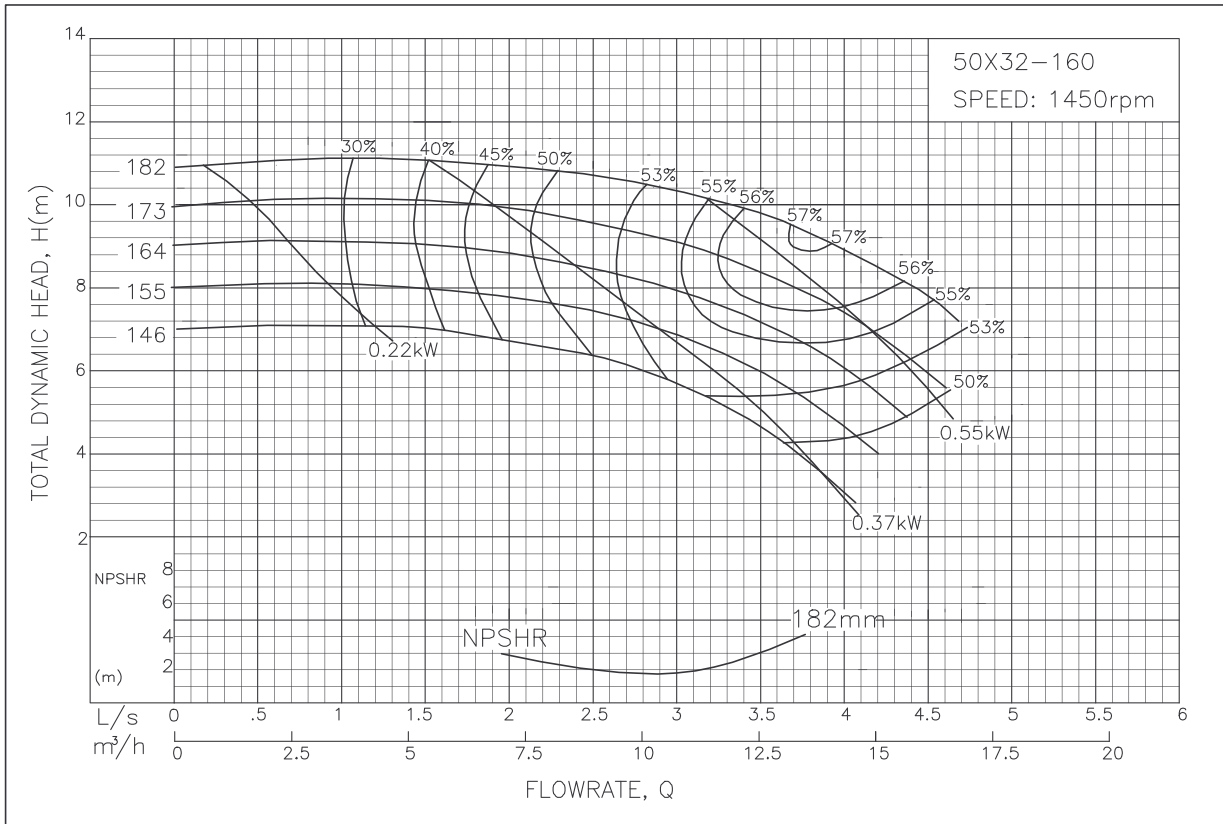

Above performance for standard construction. The efficiency correction for all stainless steel construction to be -4%.

ISO End Suction Centrifugal Pump - 50x32-200 Performance Curve

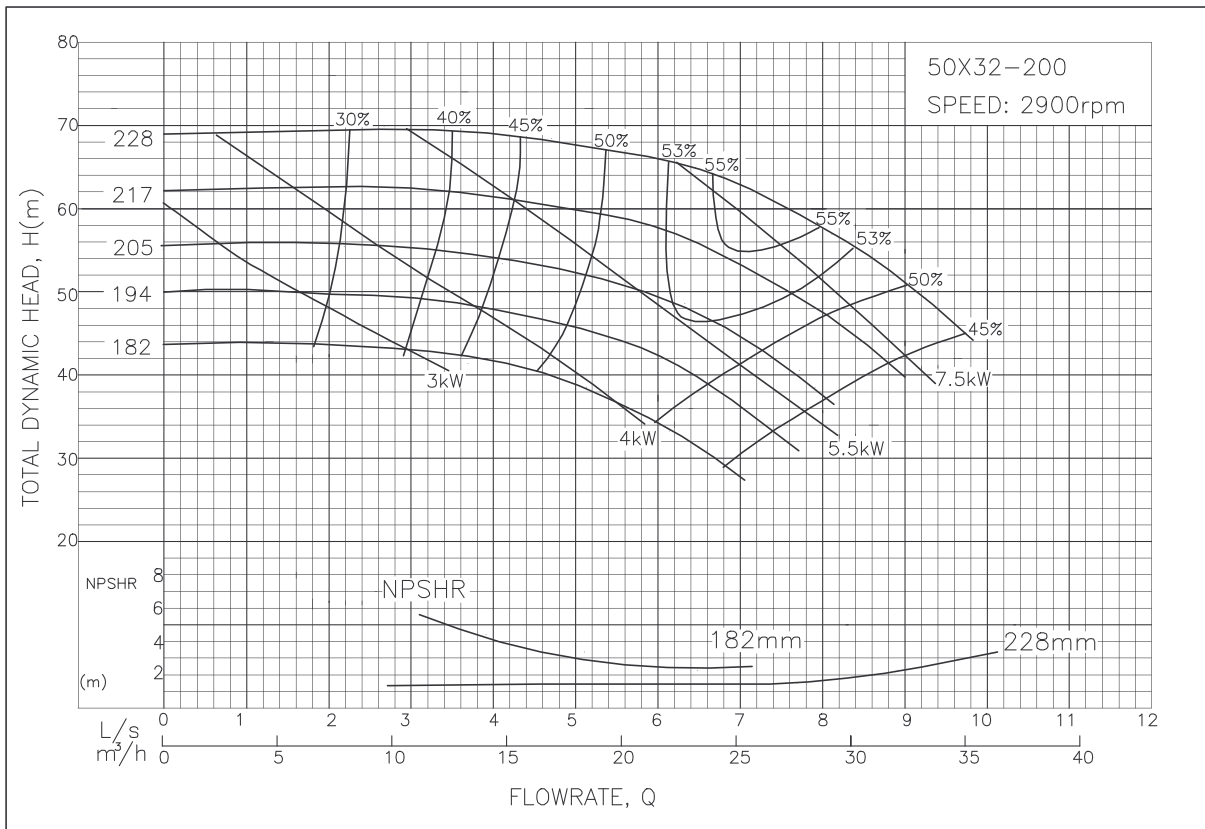
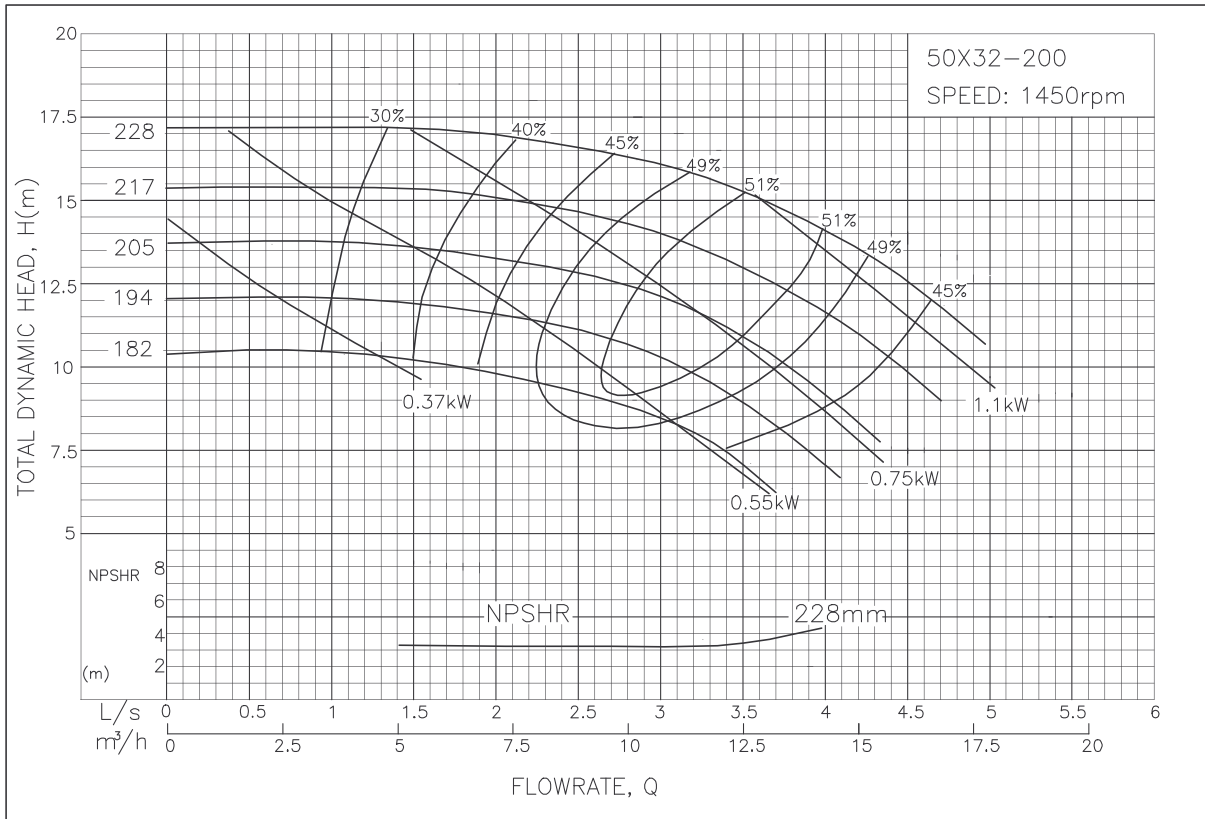

Above performance for standard construction. The efficiency correction for all stainless steel construction to be -4%.

ISO End Suction Centrifugal Pump - 65x40-200 Performance Curve

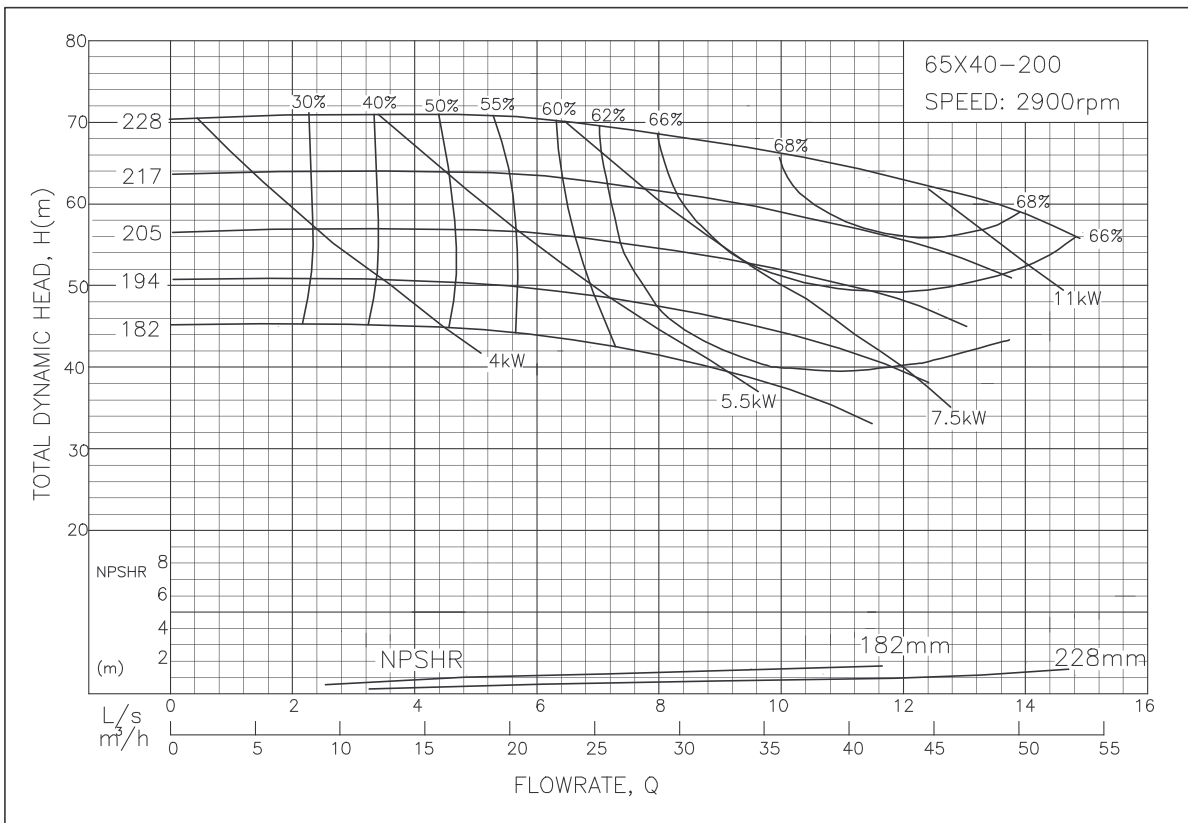
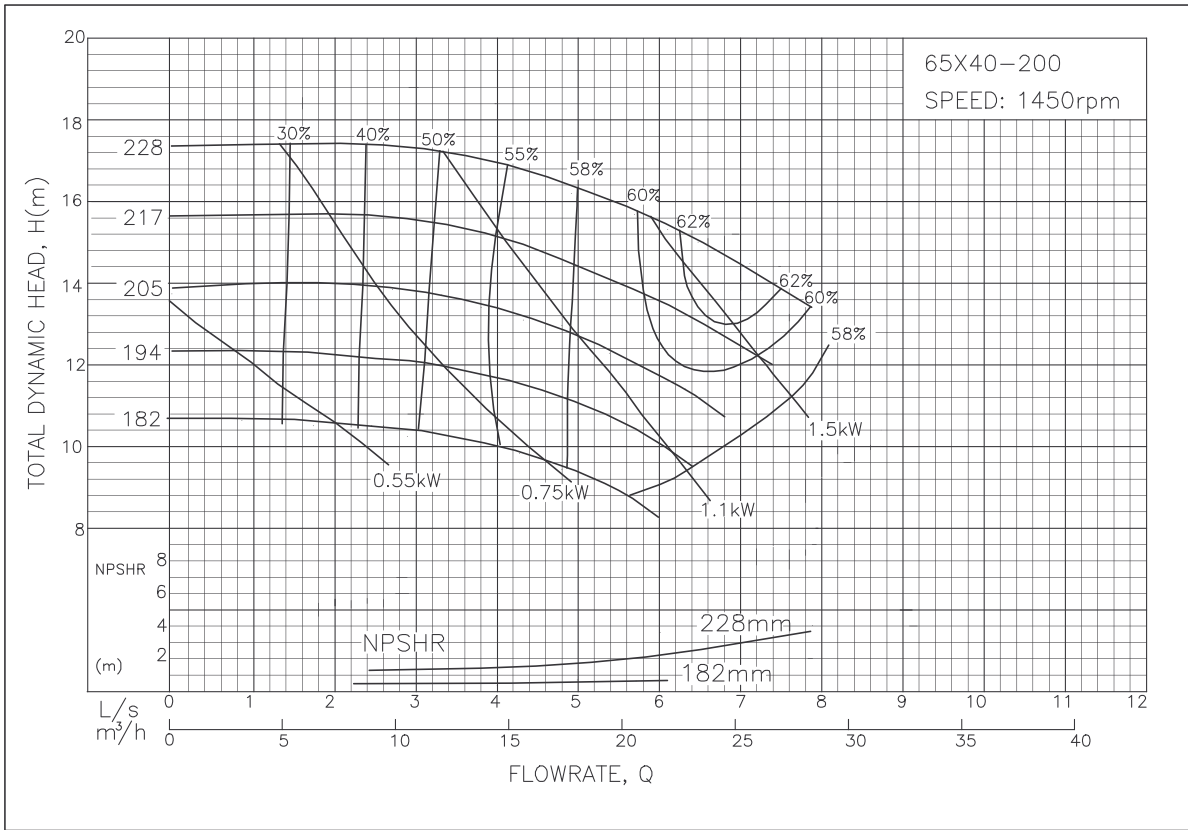

Above performance for standard construction. The efficiency correction for all stainless steel construction to be -4%.

ISO End Suction Centrifugal Pump - 65x40-250 Performance Curve

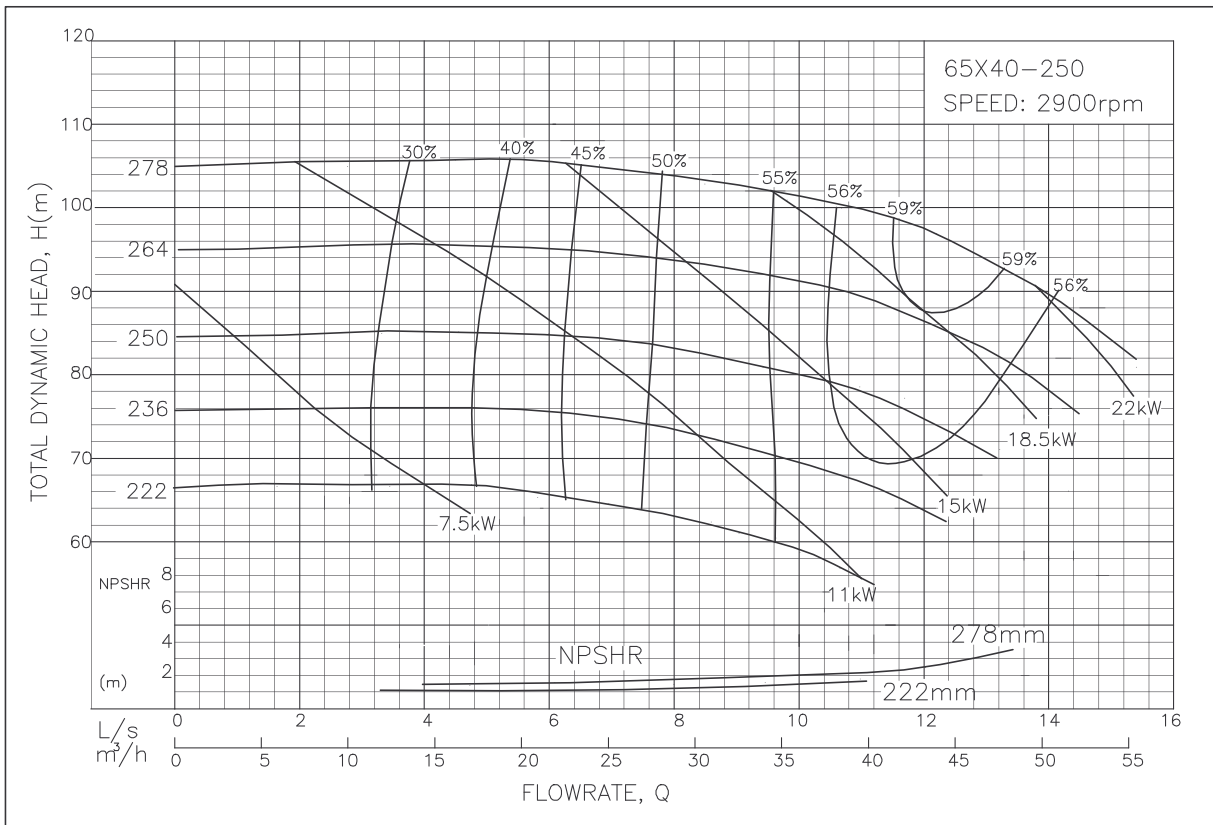
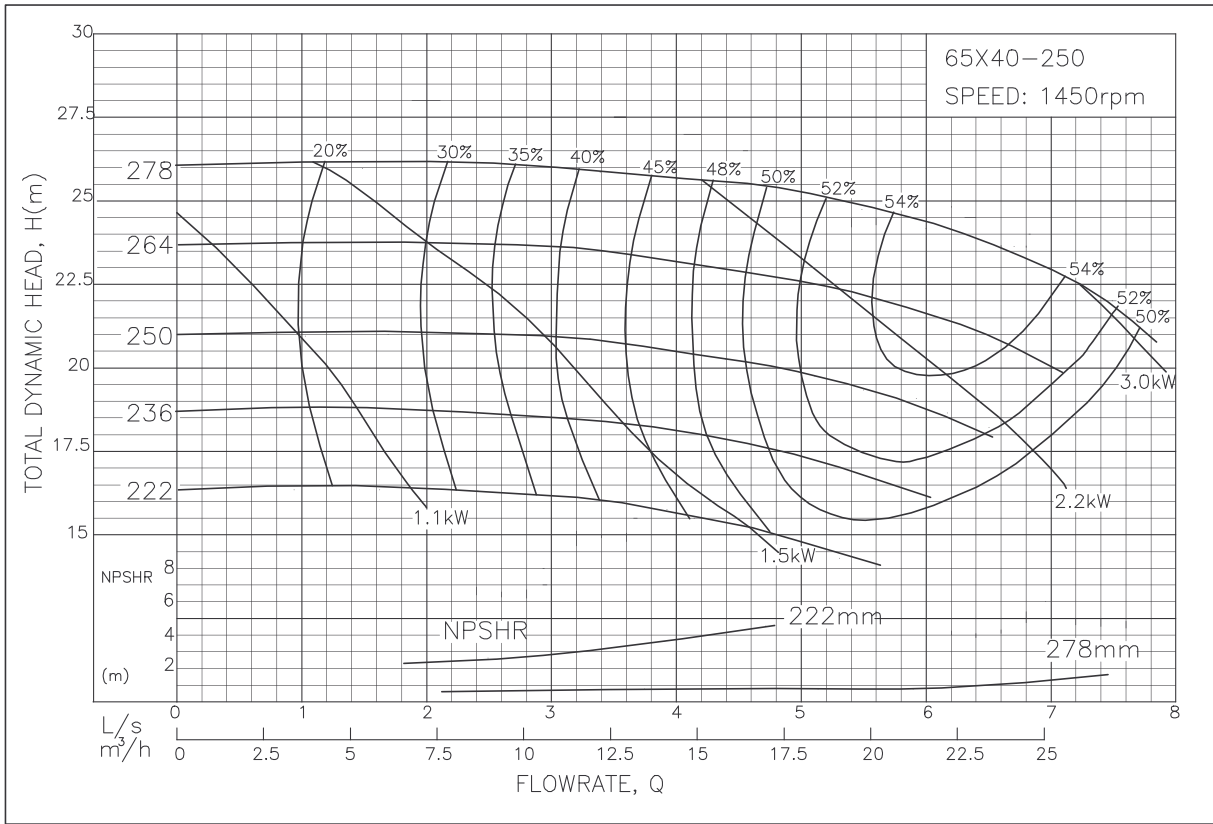

Above performance for standard construction. The efficiency correction for all stainless steel construction to be -4%.

ISO End Suction Centrifugal Pump - 65x40-315 Performance Curve

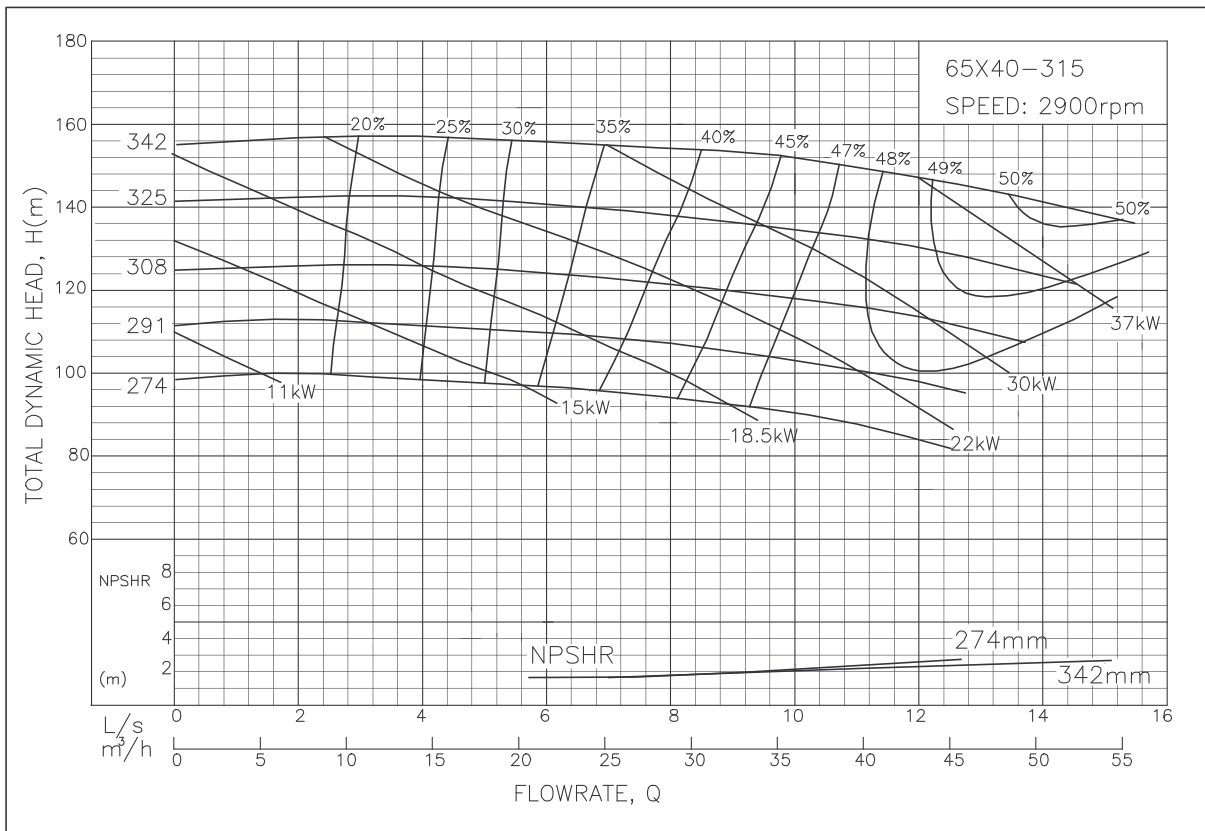
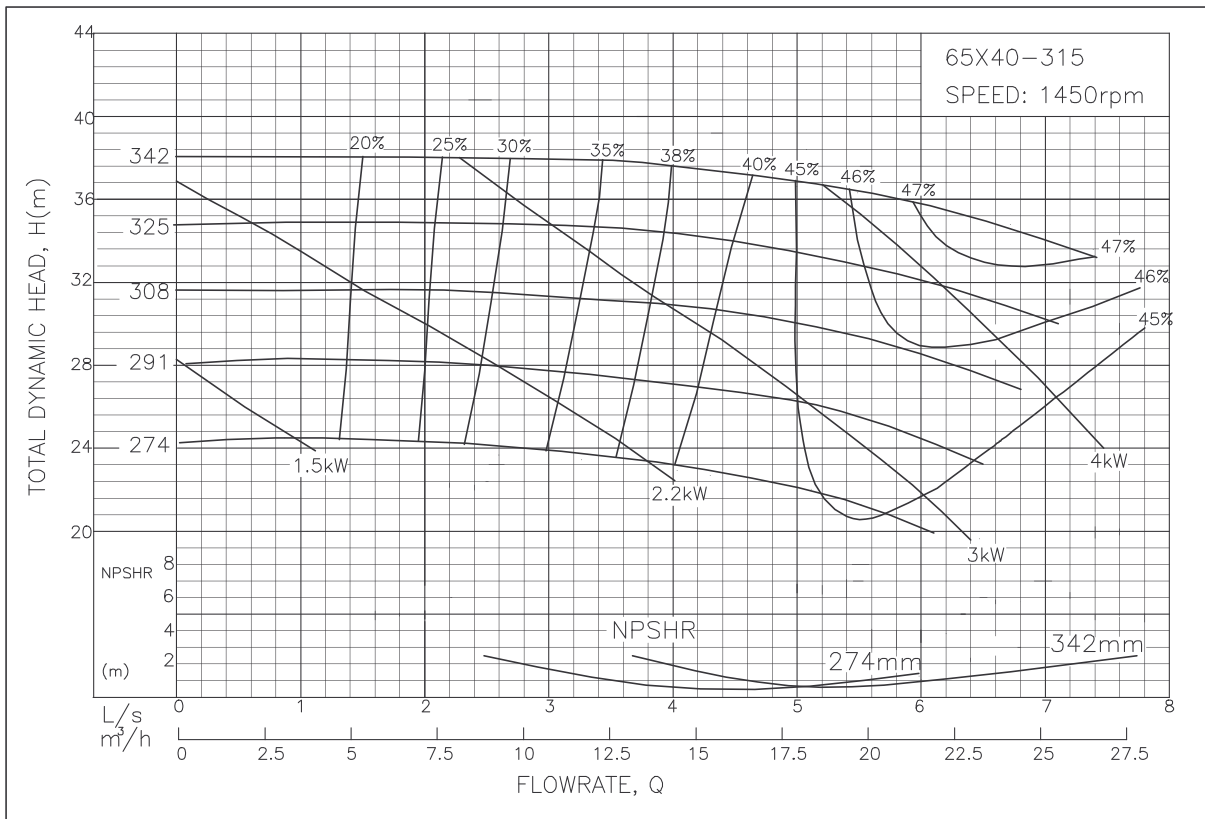

Above performance for standard construction. The efficiency correction for all stainless steel construction to be -4%.

ISO End Suction Centrifugal Pump - 65x50-160 Performance Curve

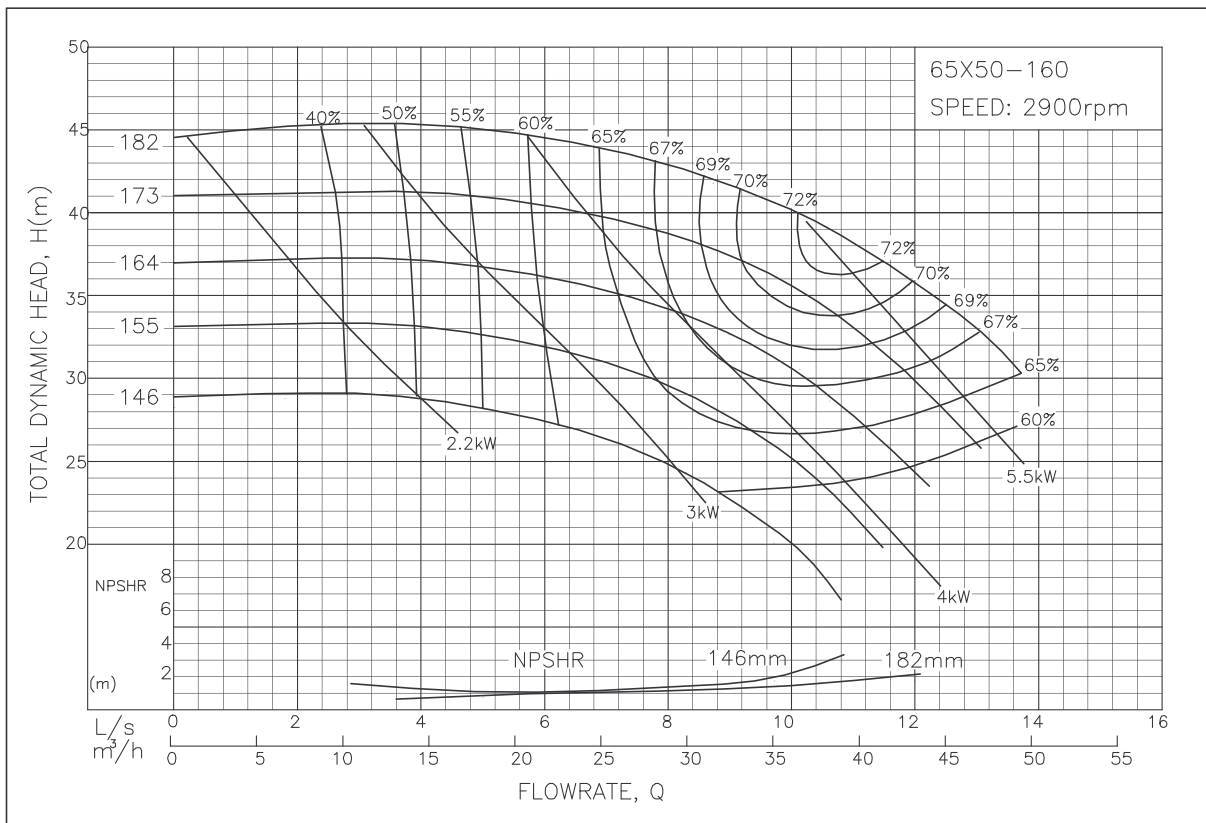
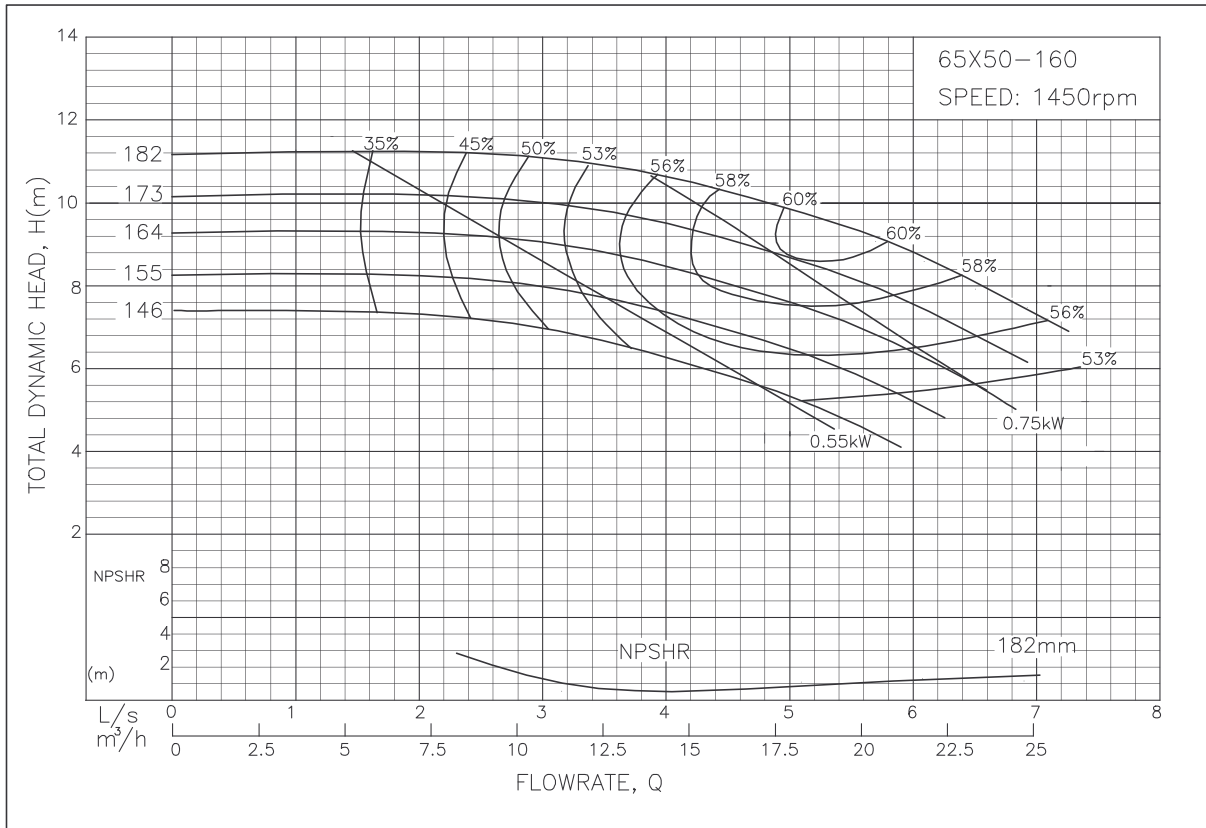

Above performance for standard construction. The efficiency correction for all stainless steel construction to be -4%.

ISO End Suction Centrifugal Pump - 80x50-200 Performance Curve

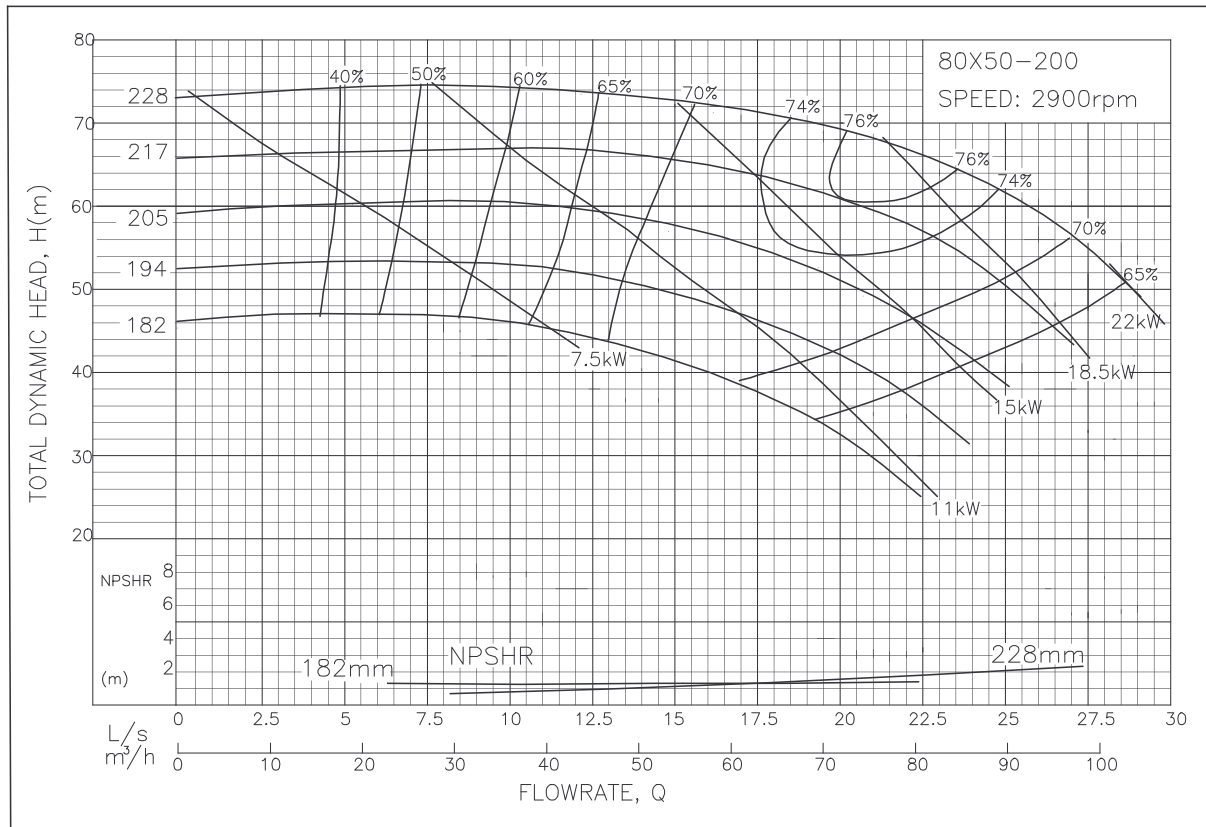
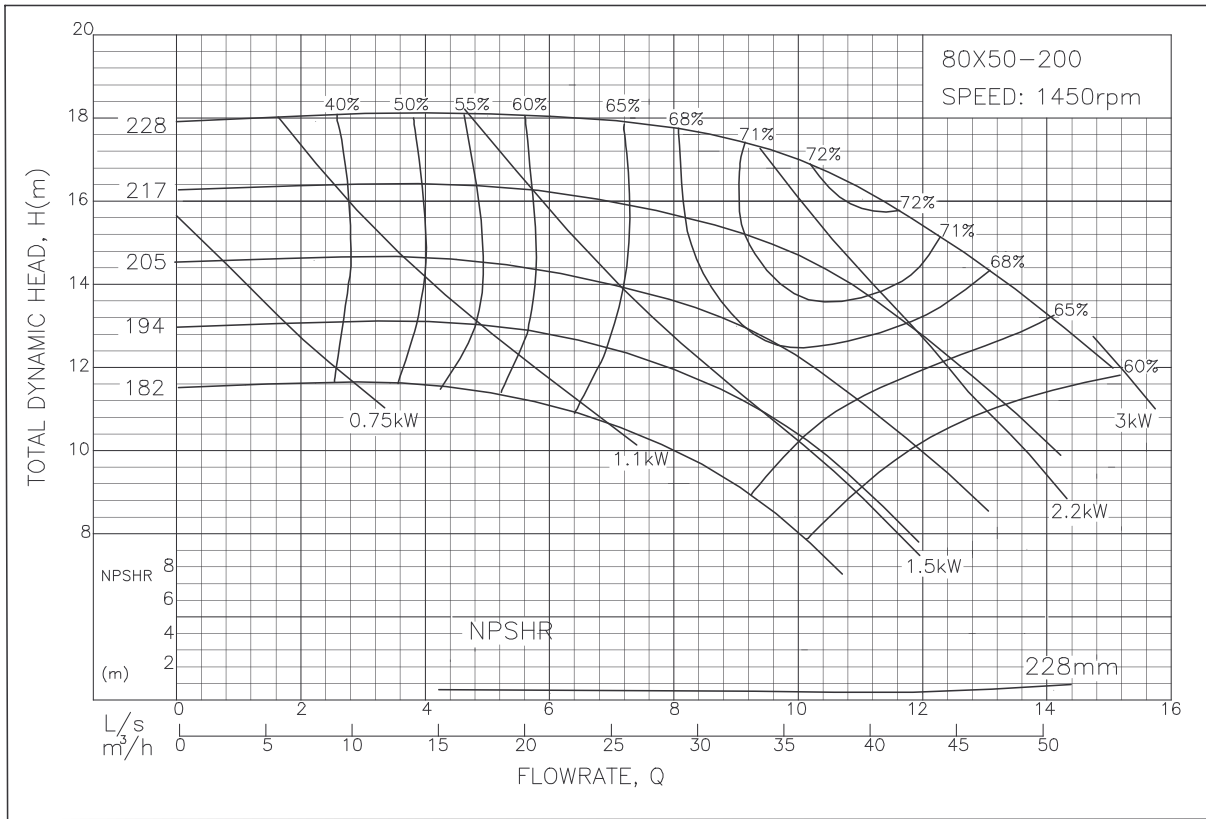

Above performance for standard construction. The efficiency correction for all stainless steel construction to be -4%.

ISO End Suction Centrifugal Pump - 80x50-250 Performance Curve

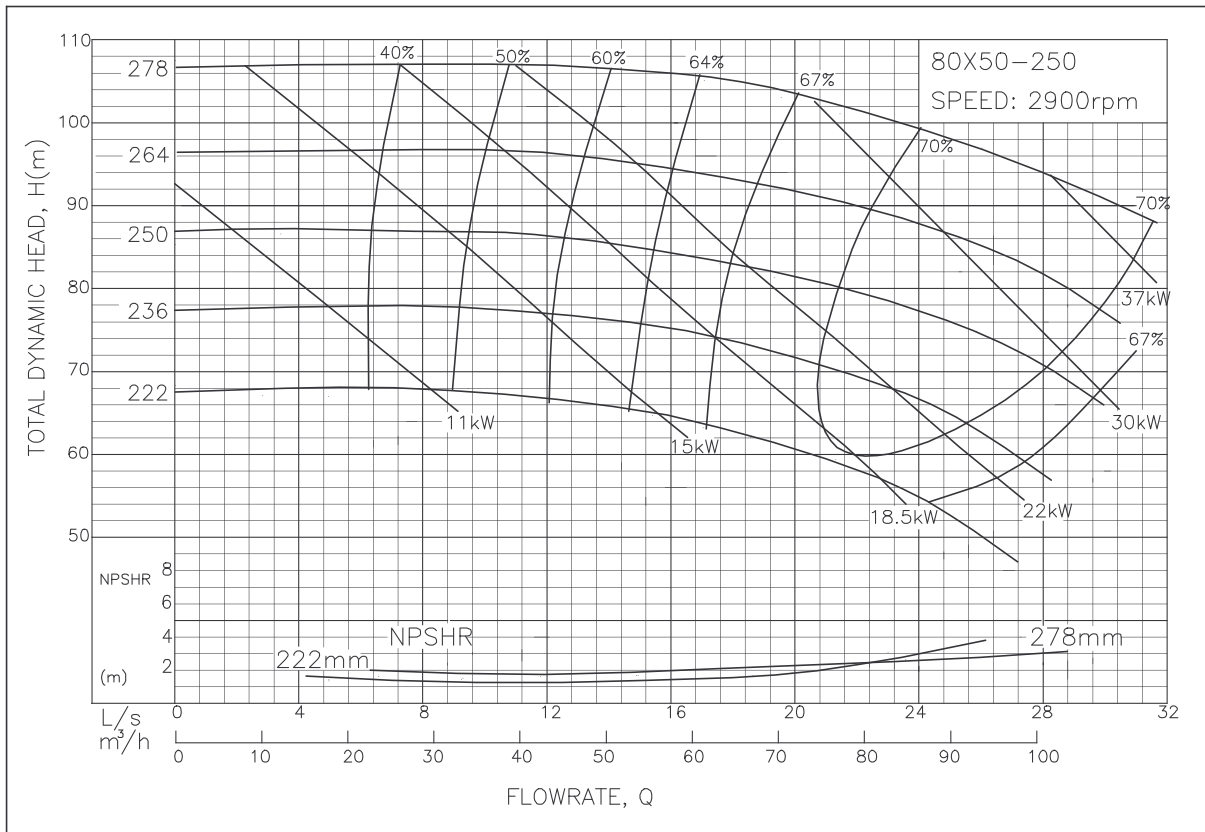
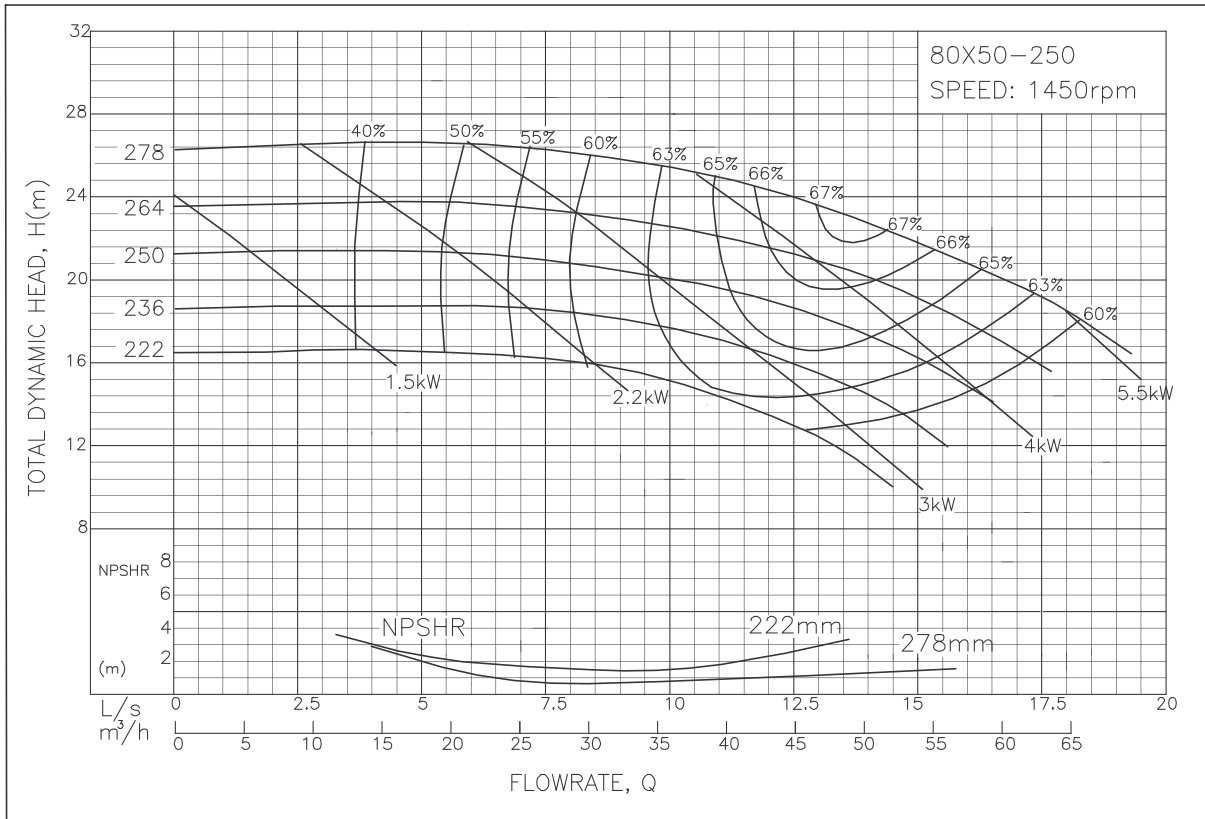

Above performance for standard construction. The efficiency correction for all stainless steel construction to be -4%.

ISO End Suction Centrifugal Pump - 80x50-315 Performance Curve

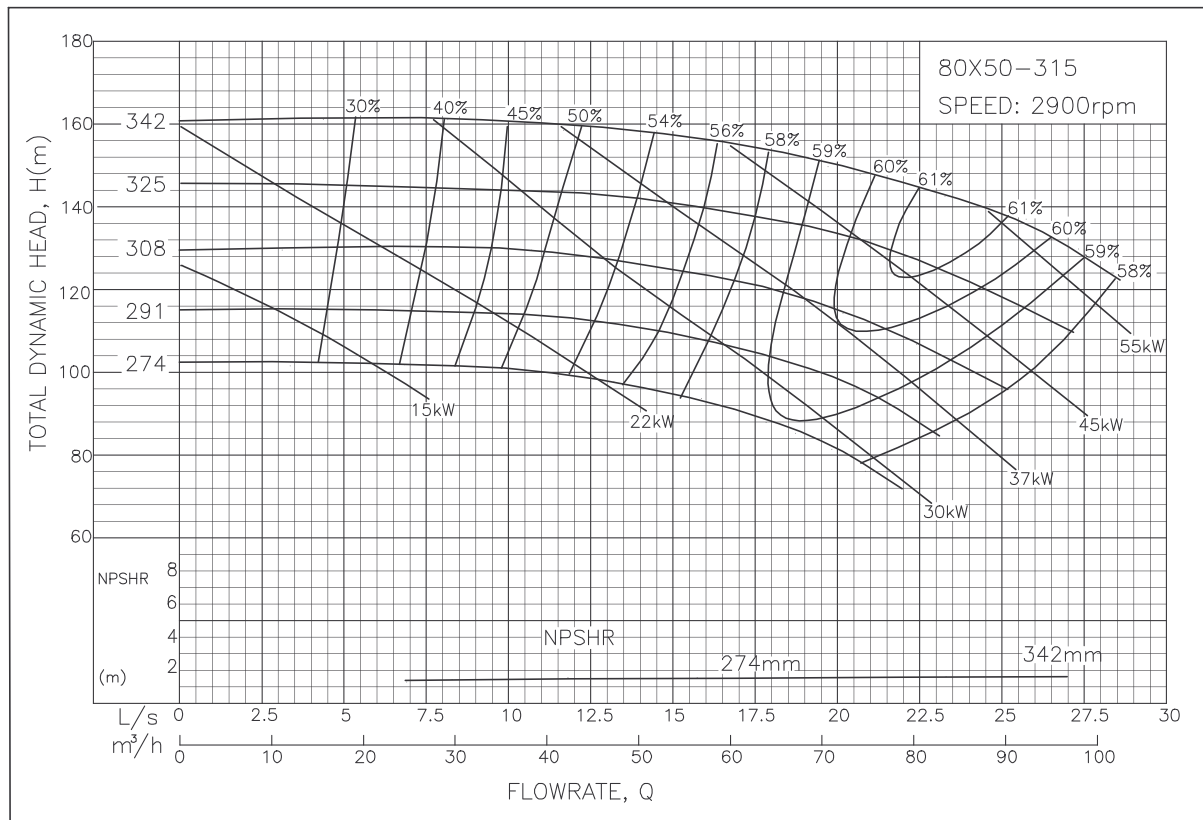
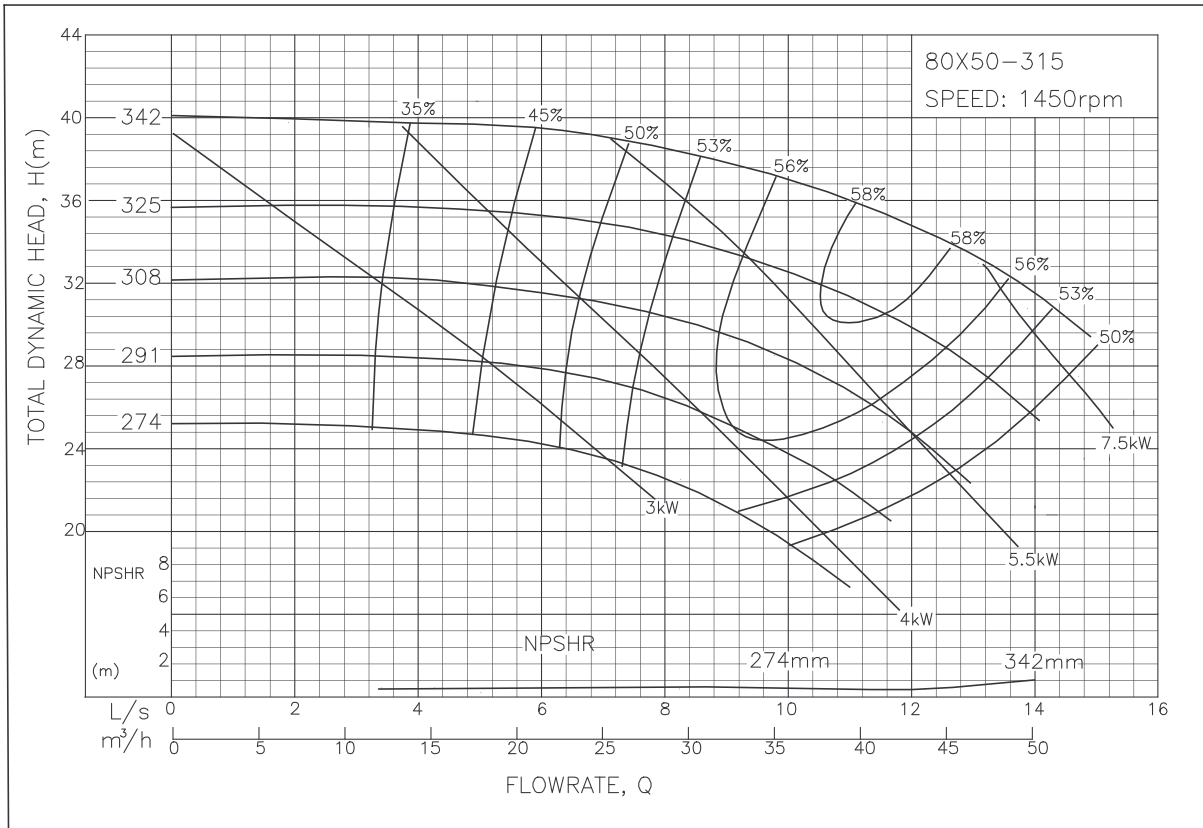

Above performance for standard construction. The efficiency correction for all stainless steel construction to be -4%.

ISO End Suction Centrifugal Pump - 80x65-160 Performance Curve

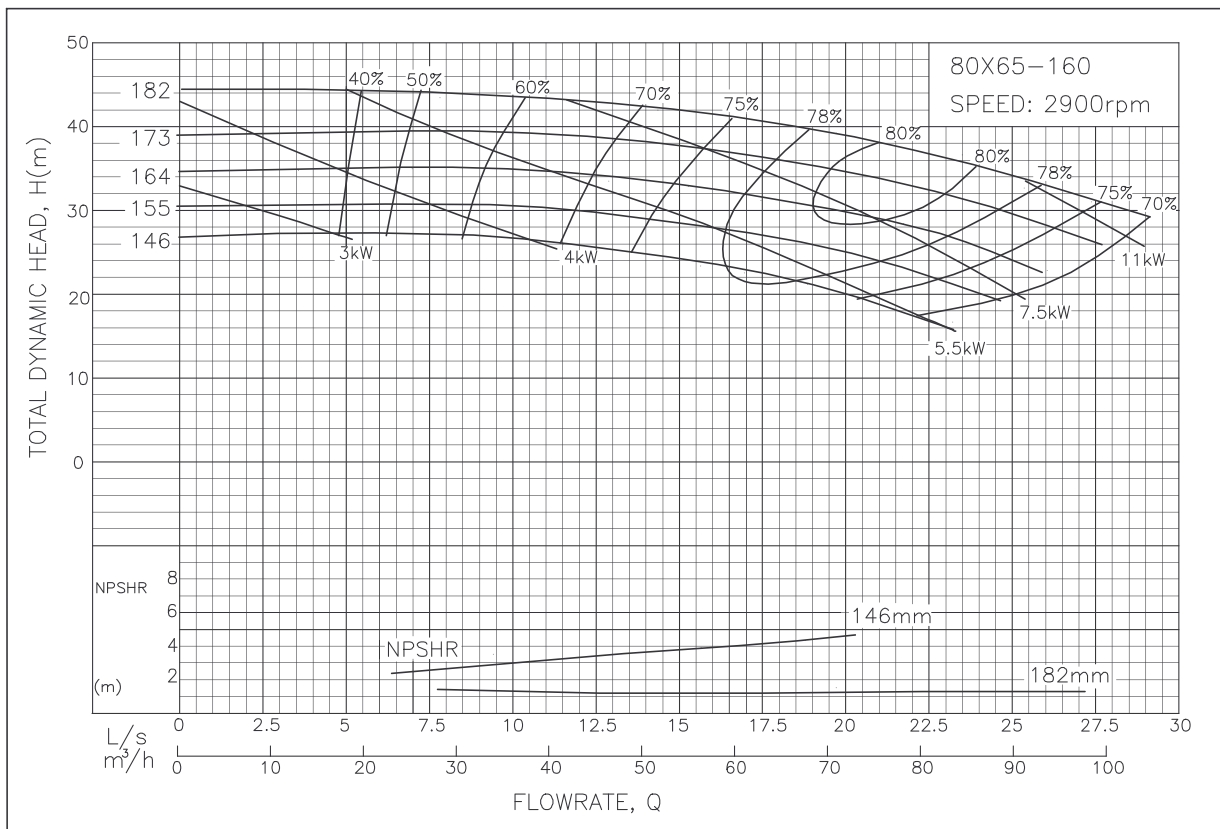
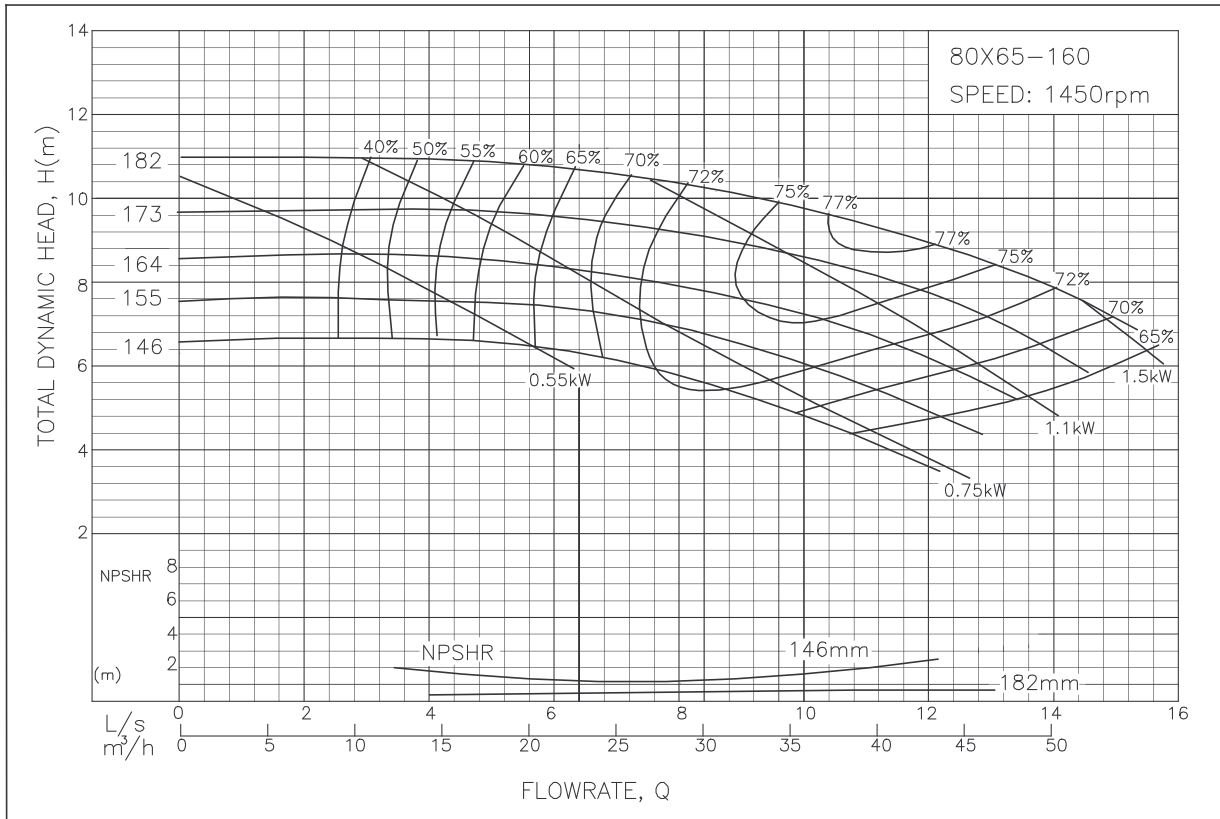

Above performance for standard construction. The efficiency correction for all stainless steel construction to be -4%.

ISO End Suction Centrifugal Pump - 100x65-200 Performance Curve

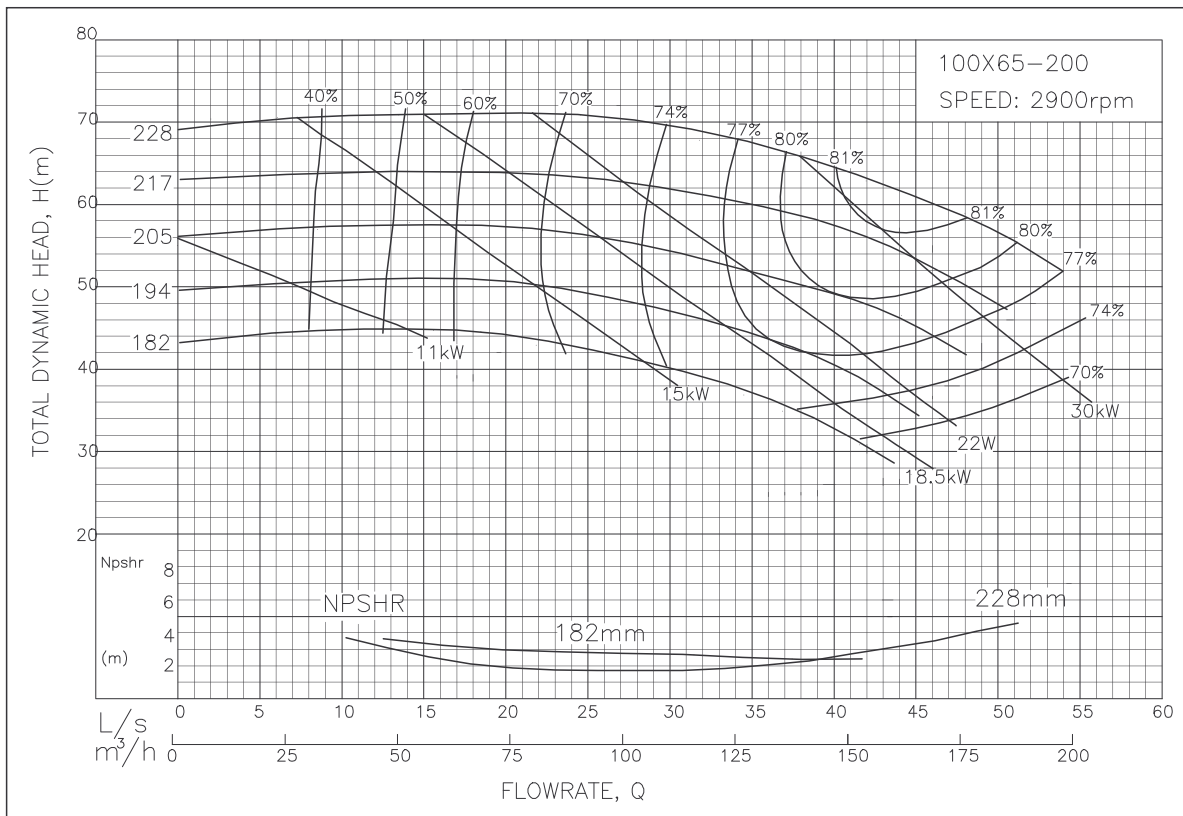
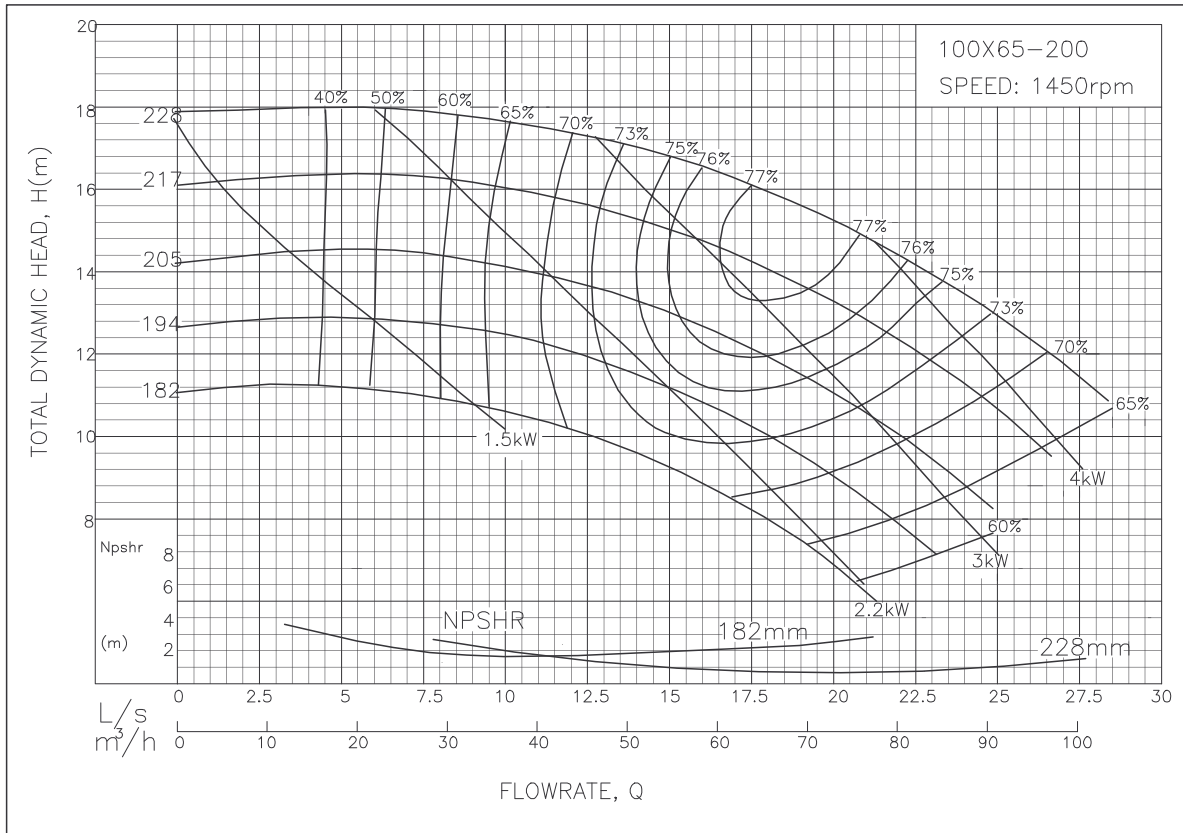

Above performance for standard construction. The efficiency correction for all stainless steel construction to be -4%.

ISO End Suction Centrifugal Pump - 100x65-250 Performance Curve

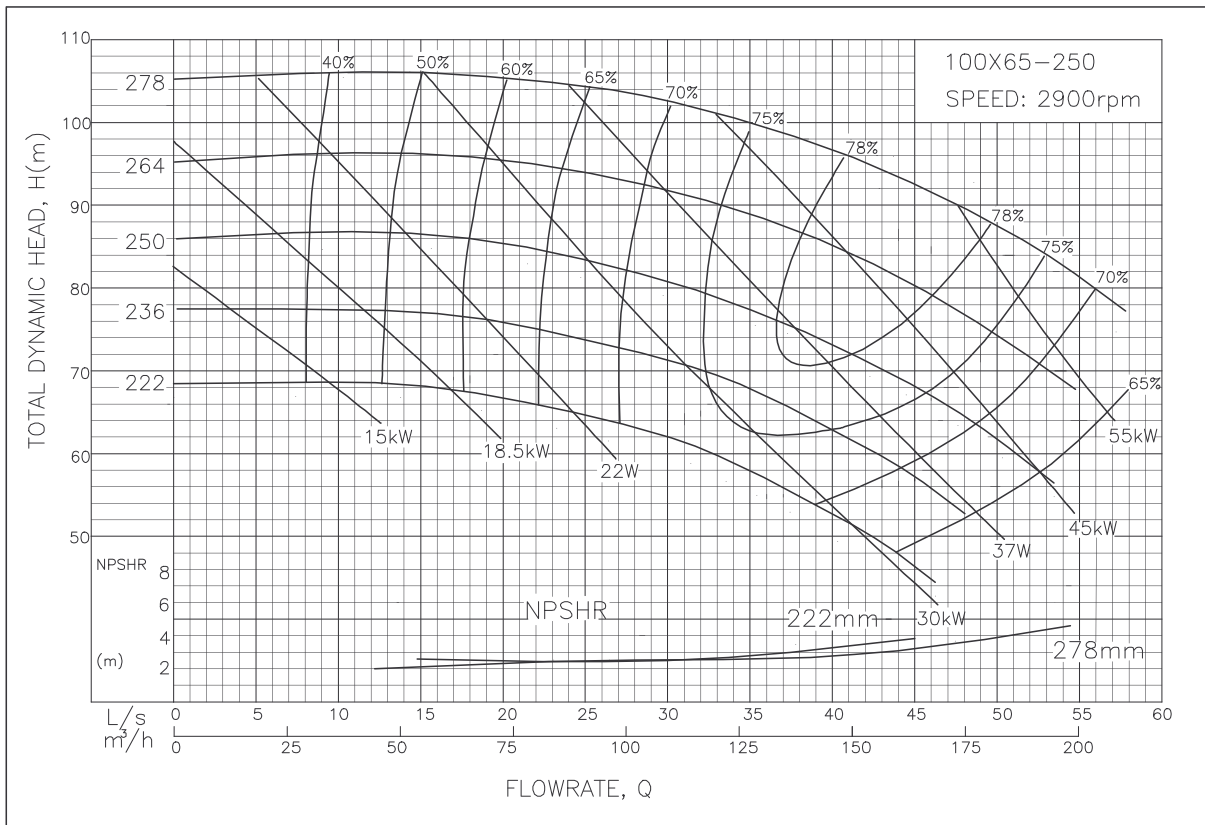
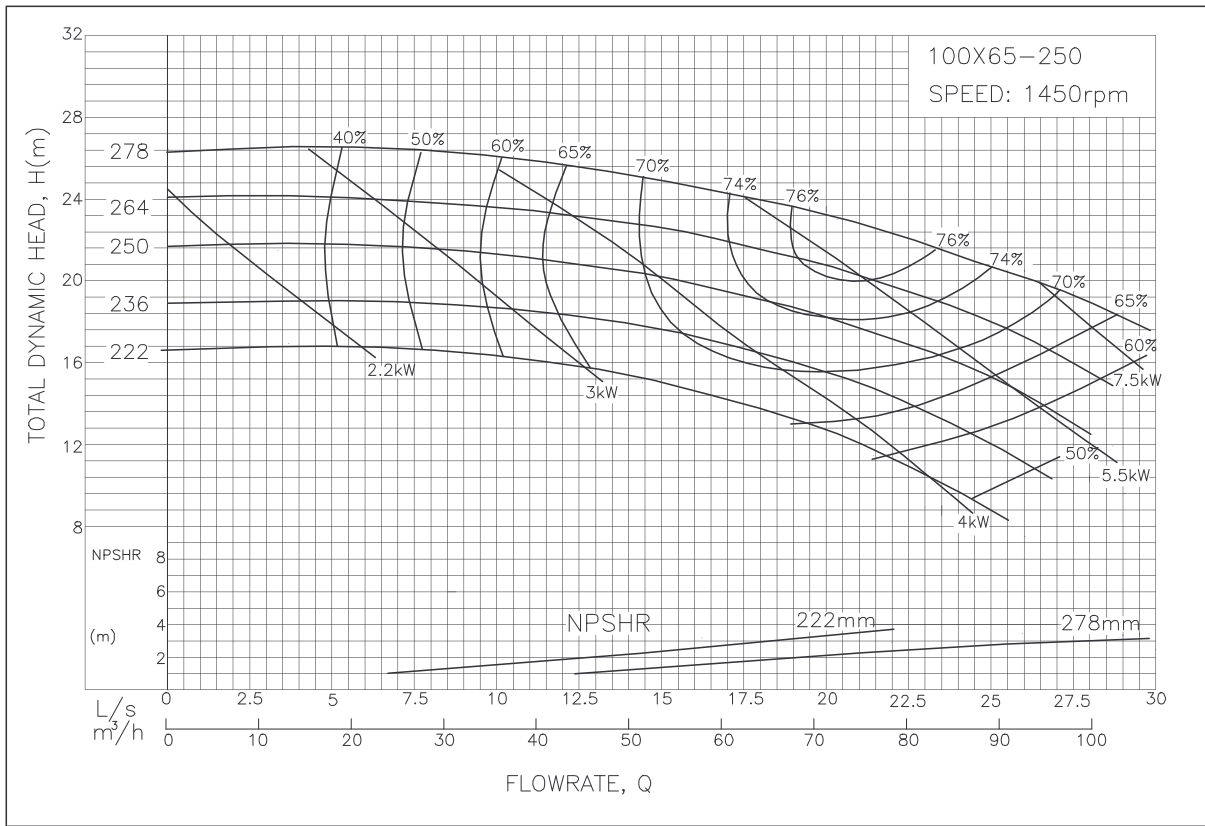

Above performance for standard construction. The efficiency correction for all stainless steel construction to be -4%.

ISO End Suction Centrifugal Pump - 100x65-315 Performance Curve

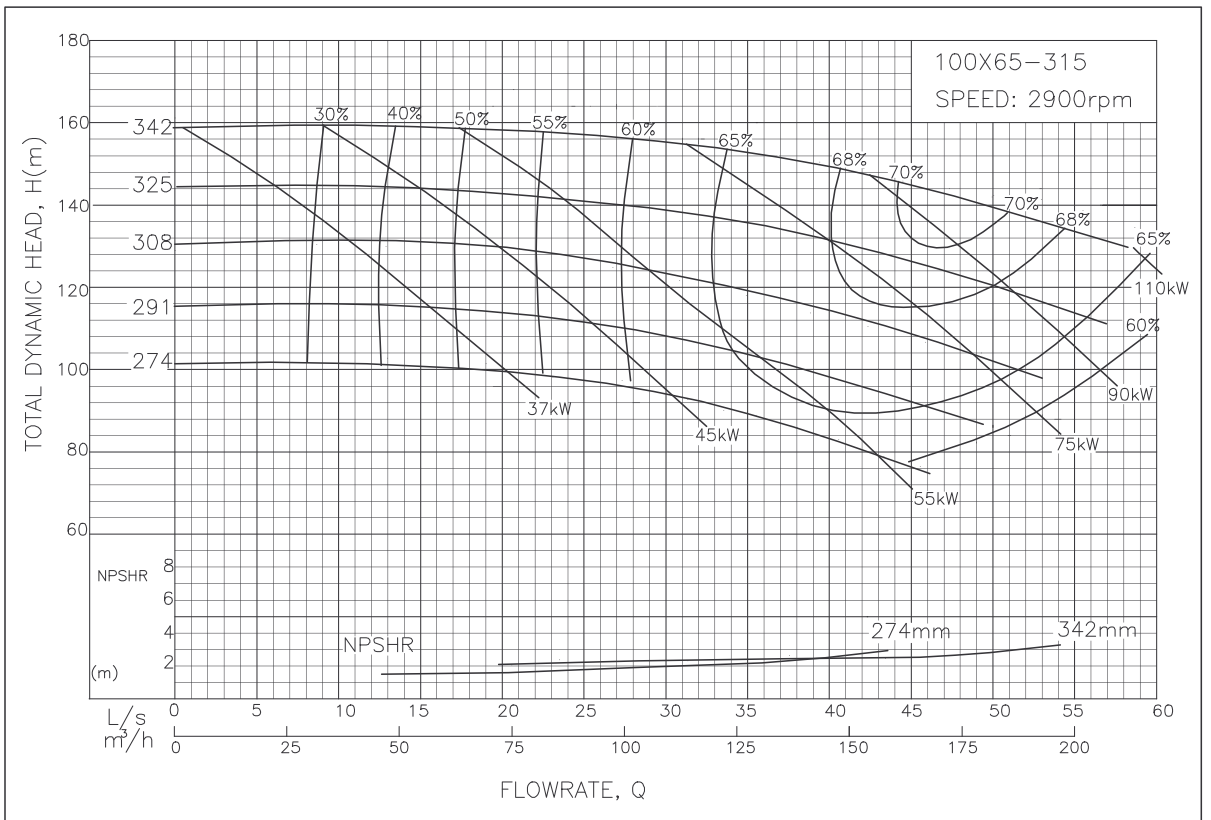
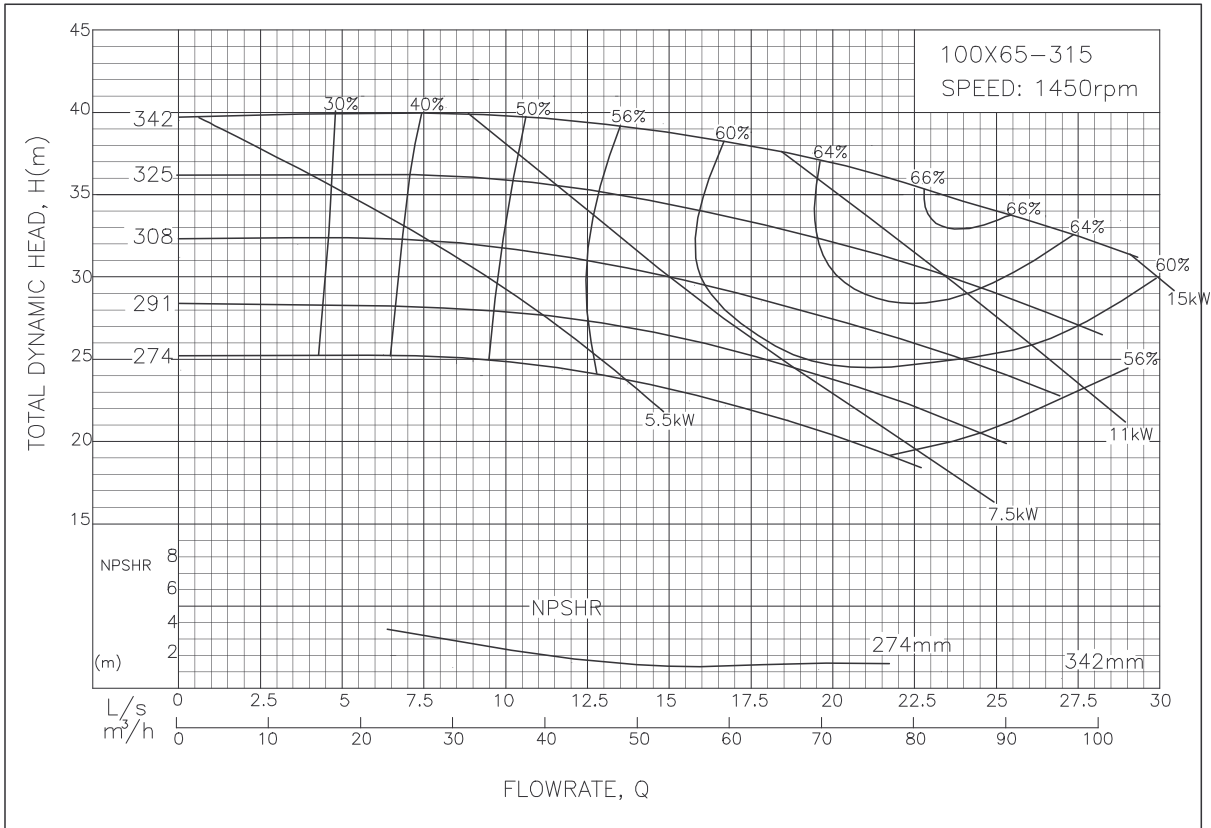

Above performance for standard construction. The efficiency correction for all stainless steel construction to be -4%.

ISO End Suction Centrifugal Pump - 100x80-160 Performance Curve

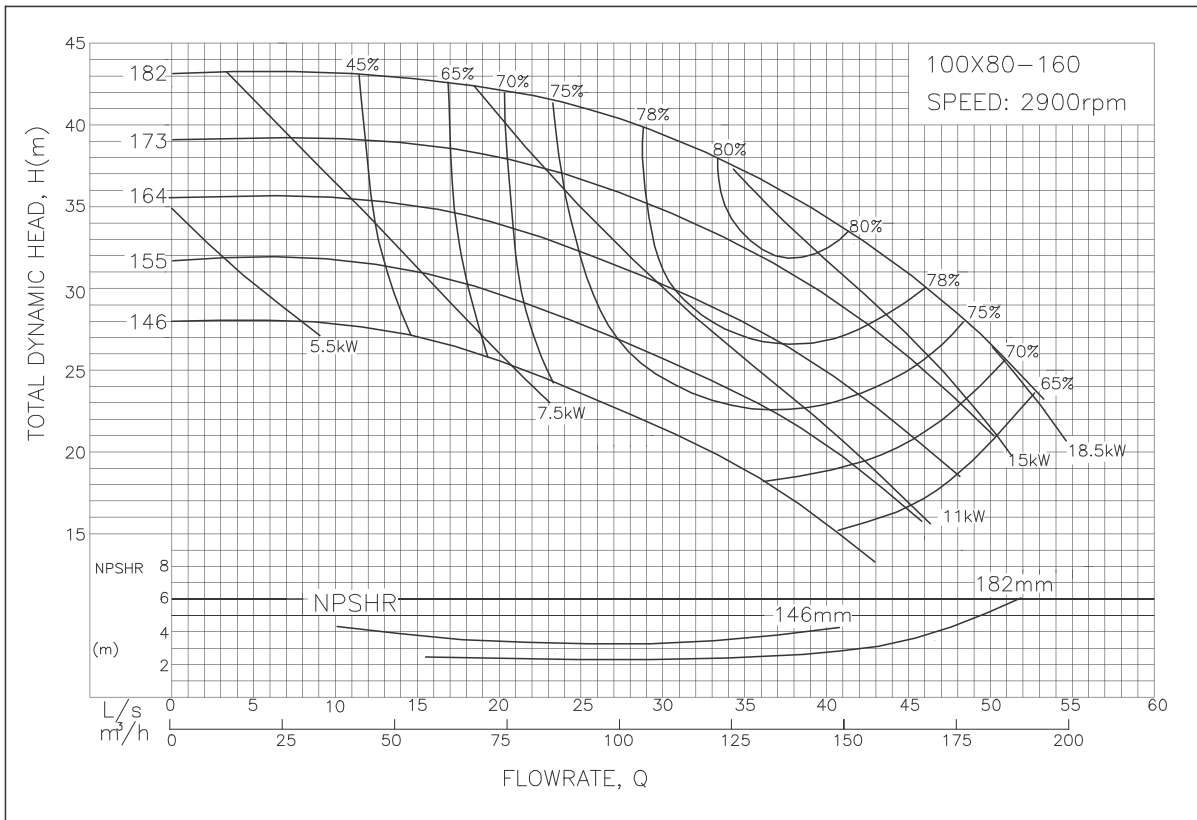
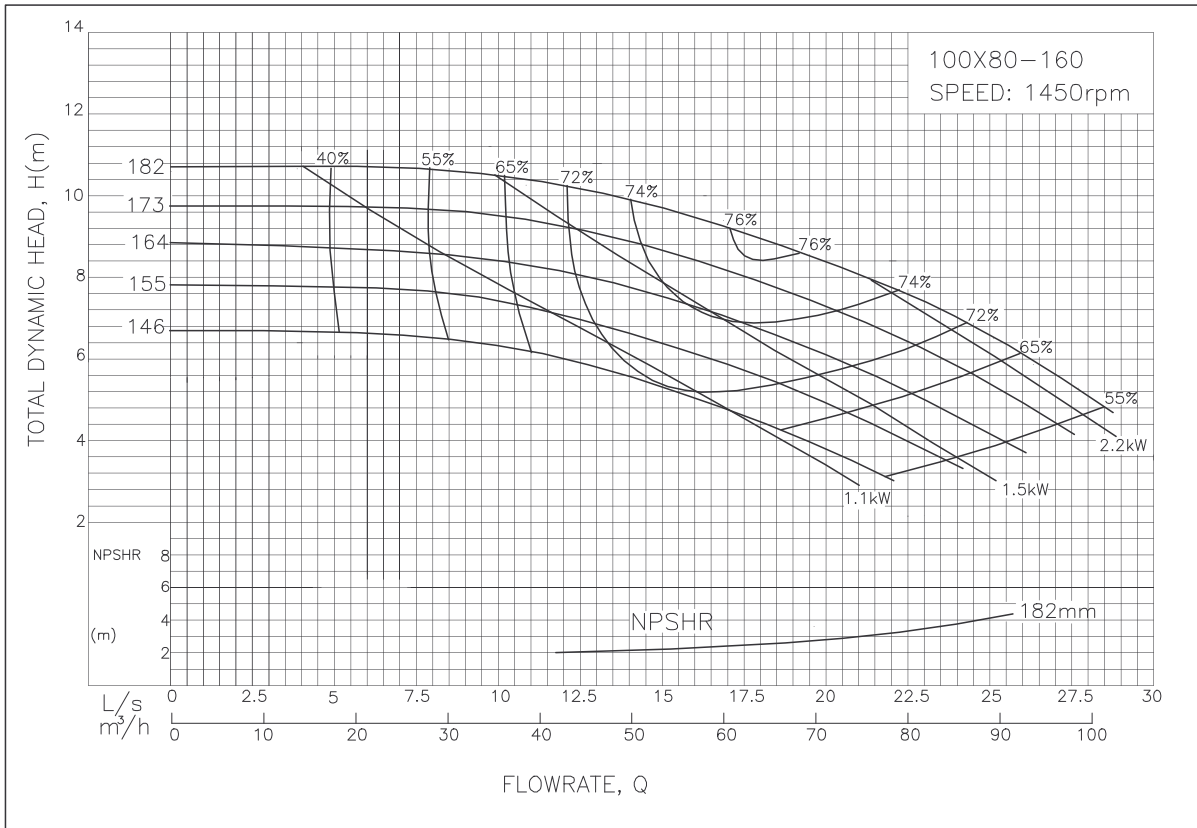

Above performance for standard construction. The efficiency correction for all stainless steel construction to be -4%.

ISO End Suction Centrifugal Pump - 125x80-400 Performance Curve (Not Available in 2900 RPM)

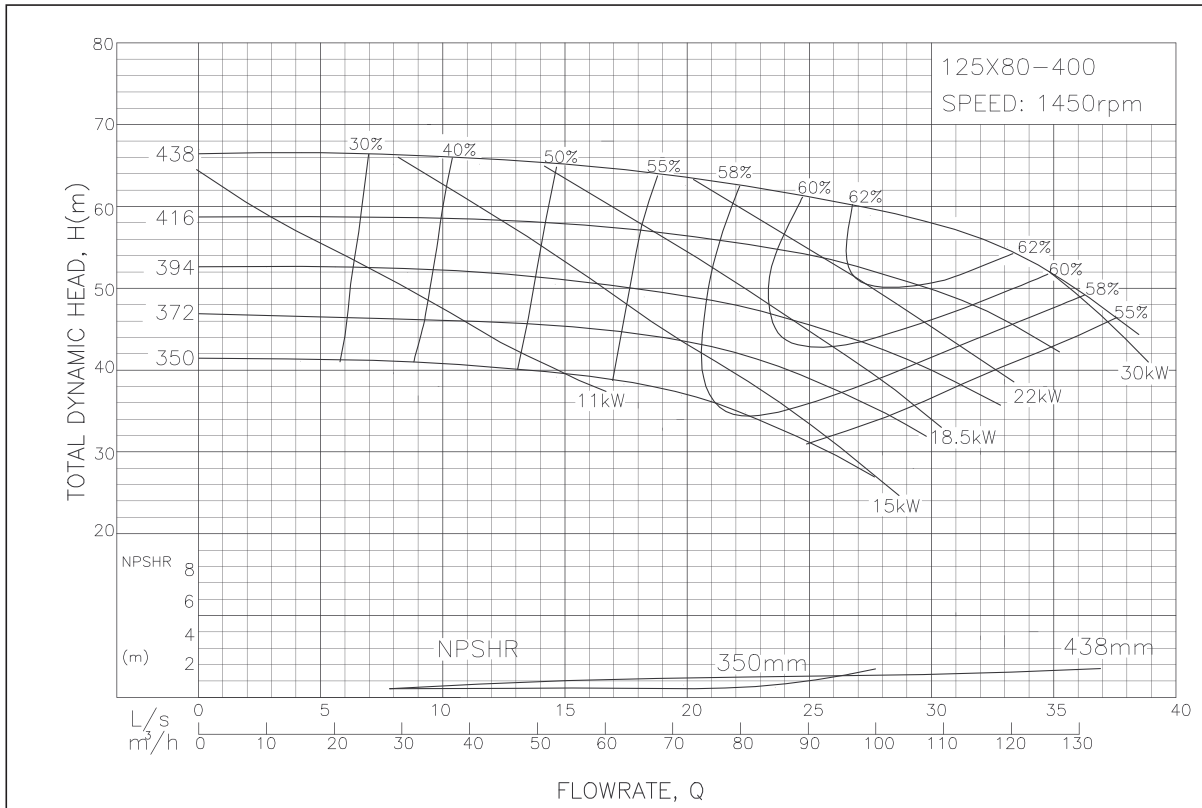

Above performance for standard construction. The efficiency correction for all stainless steel construction to be -4%.

ISO End Suction Centrifugal Pump - 125x100-200 Performance Curve

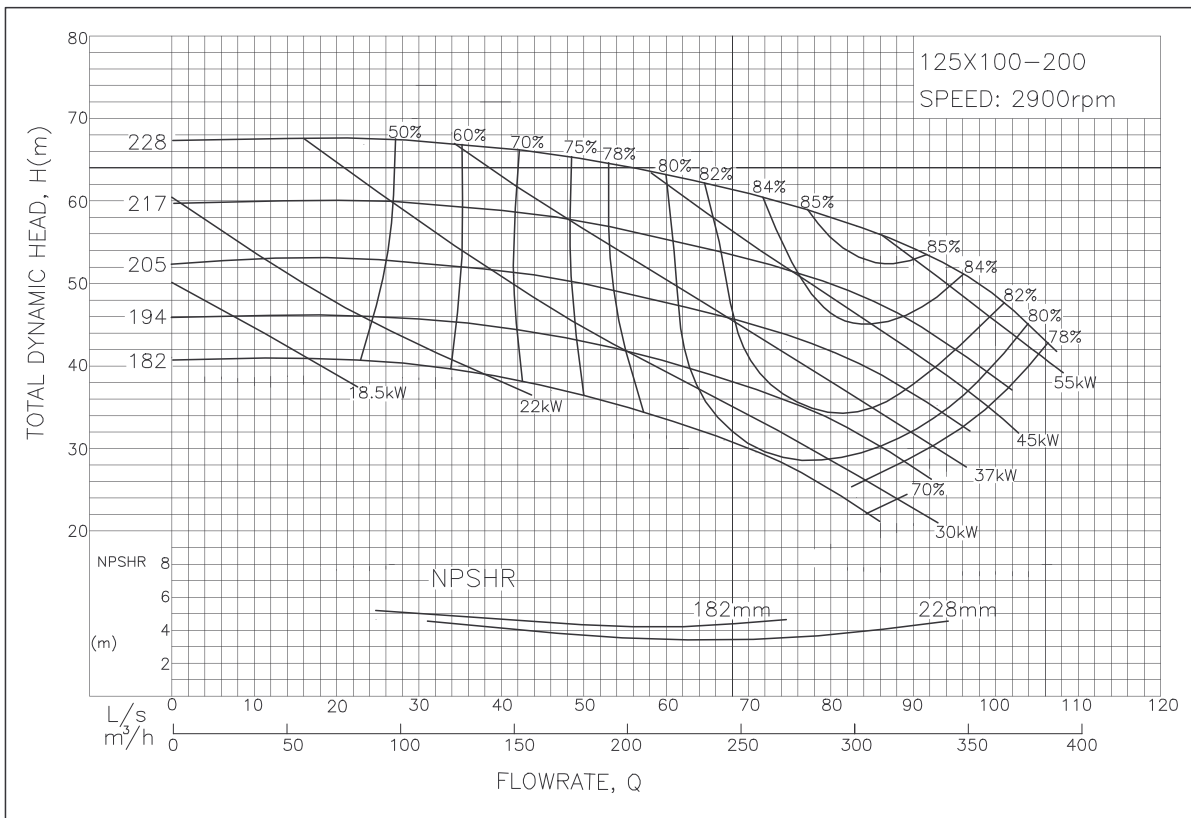
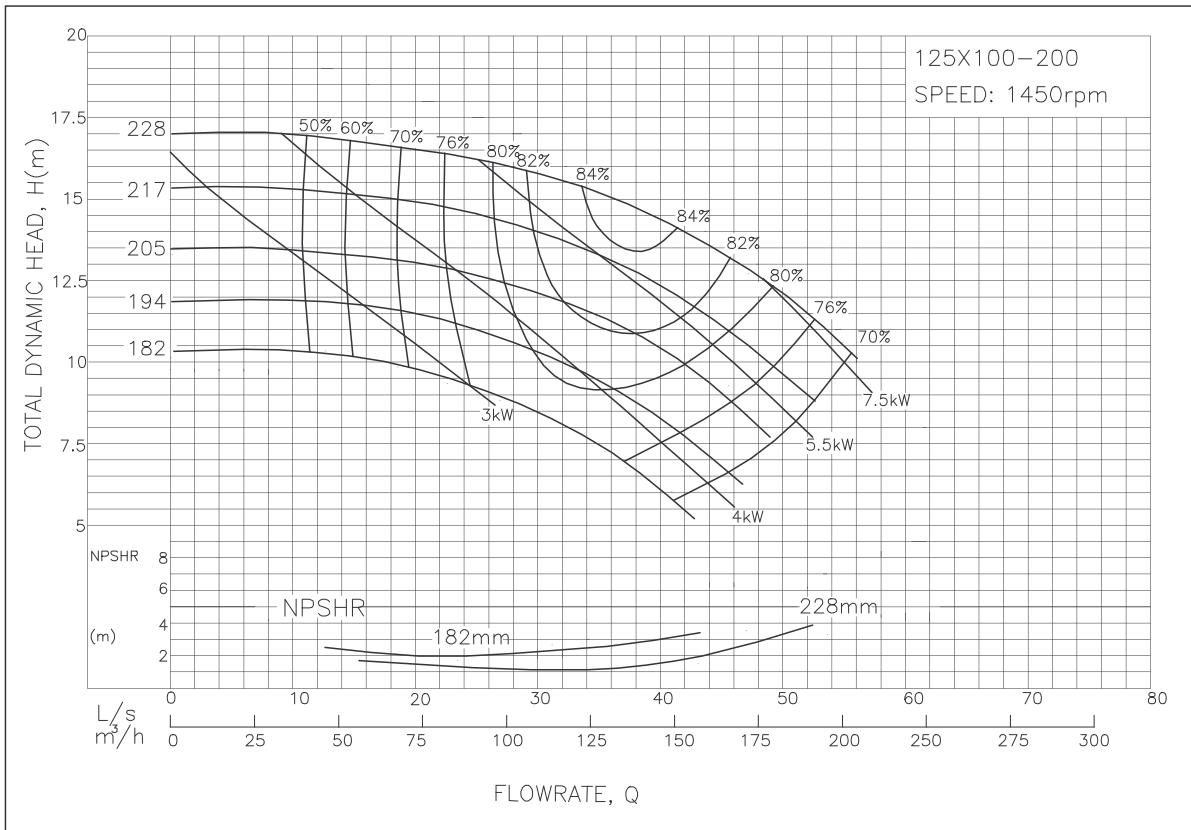

Above performance for standard construction. The efficiency correction for all stainless steel construction to be -4%.

ISO End Suction Centrifugal Pump - 125x100-250 Performance Curve

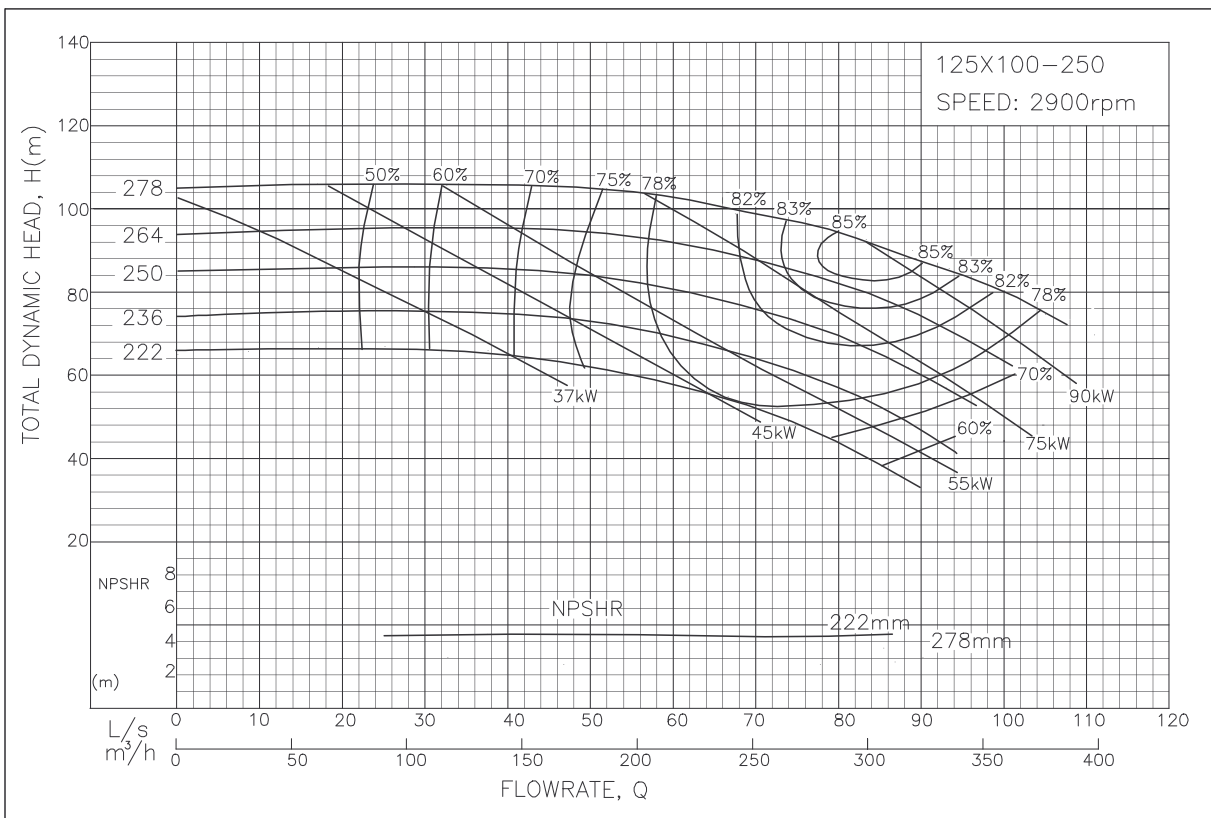
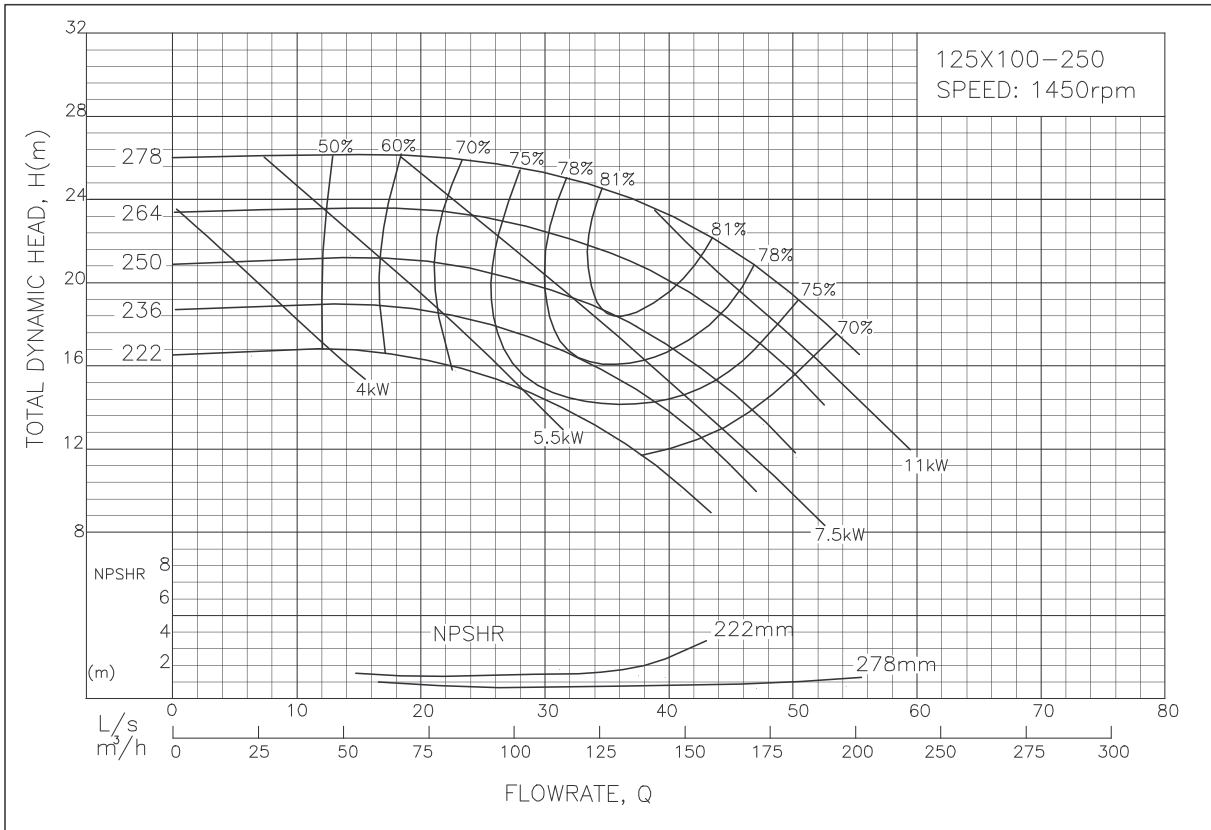

Above performance for standard construction. The efficiency correction for all stainless steel construction to be -4%.

ISO End Suction Centrifugal Pump - 125x100-315 Performance Curve

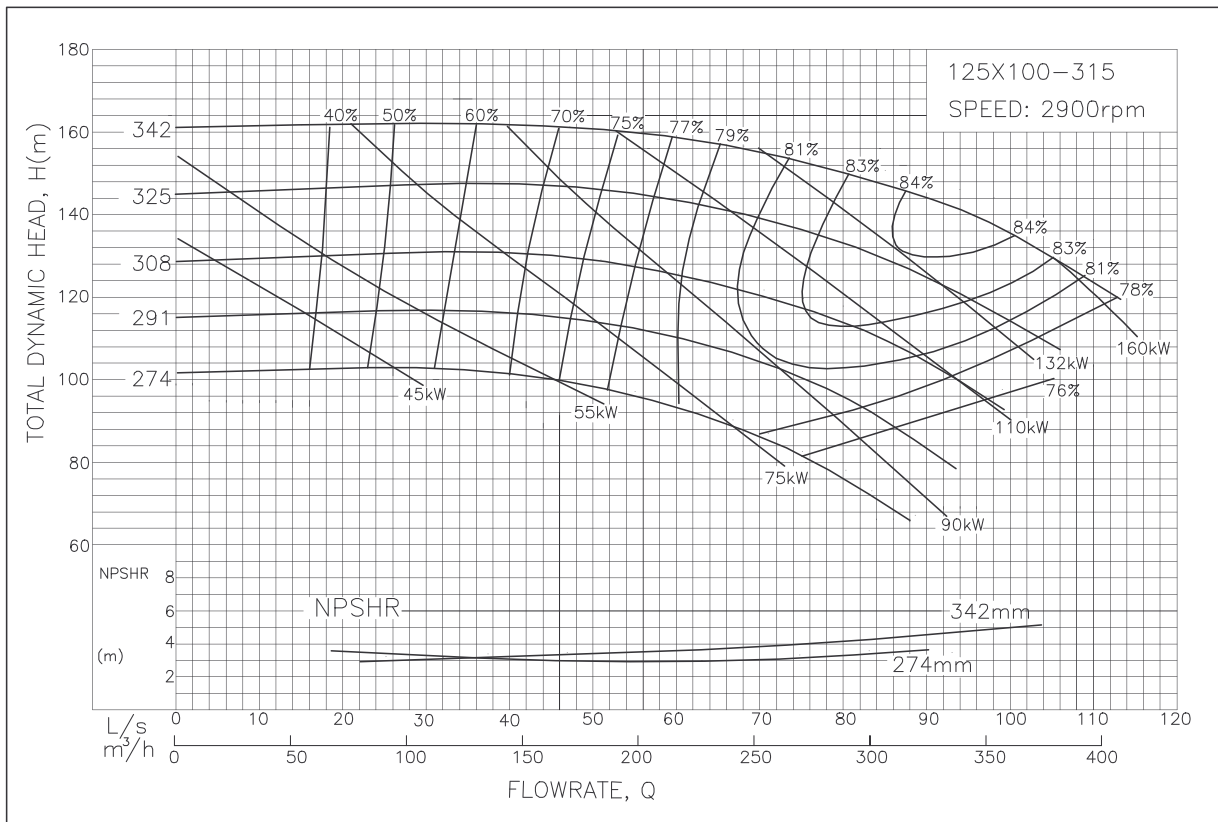
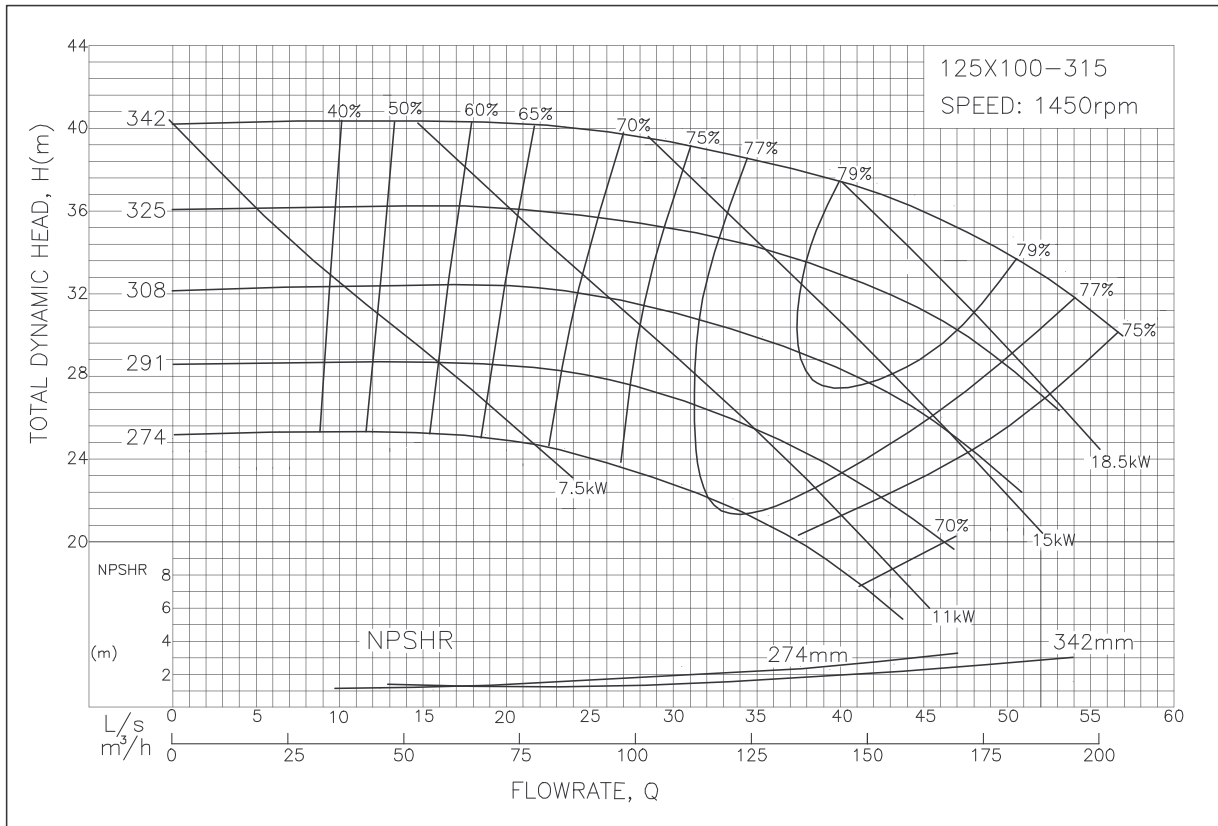

Above performance for standard construction. The efficiency correction for all stainless steel construction to be -4%.

ISO End Suction Centrifugal Pump - 125x100-400 Performance Curve

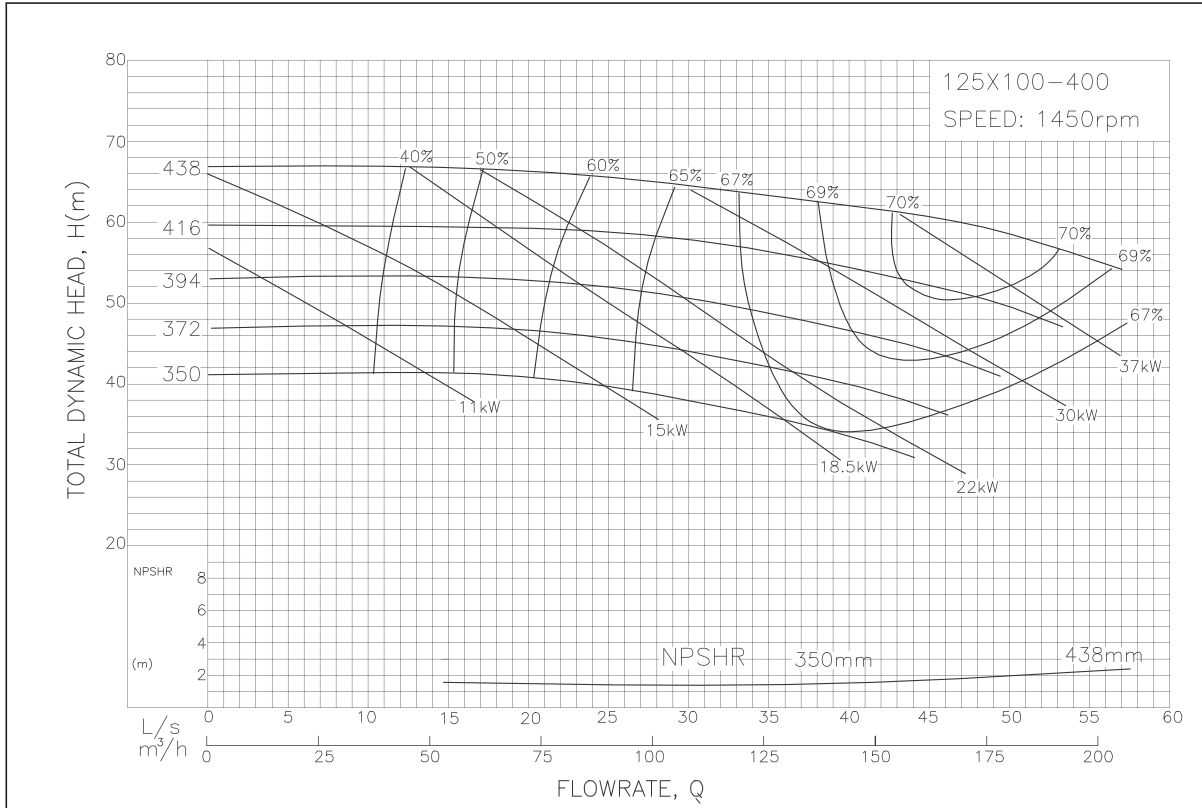

ISO End Suction Centrifugal Pump - 125x100-500 Performance Curve (Not Available in GIS)

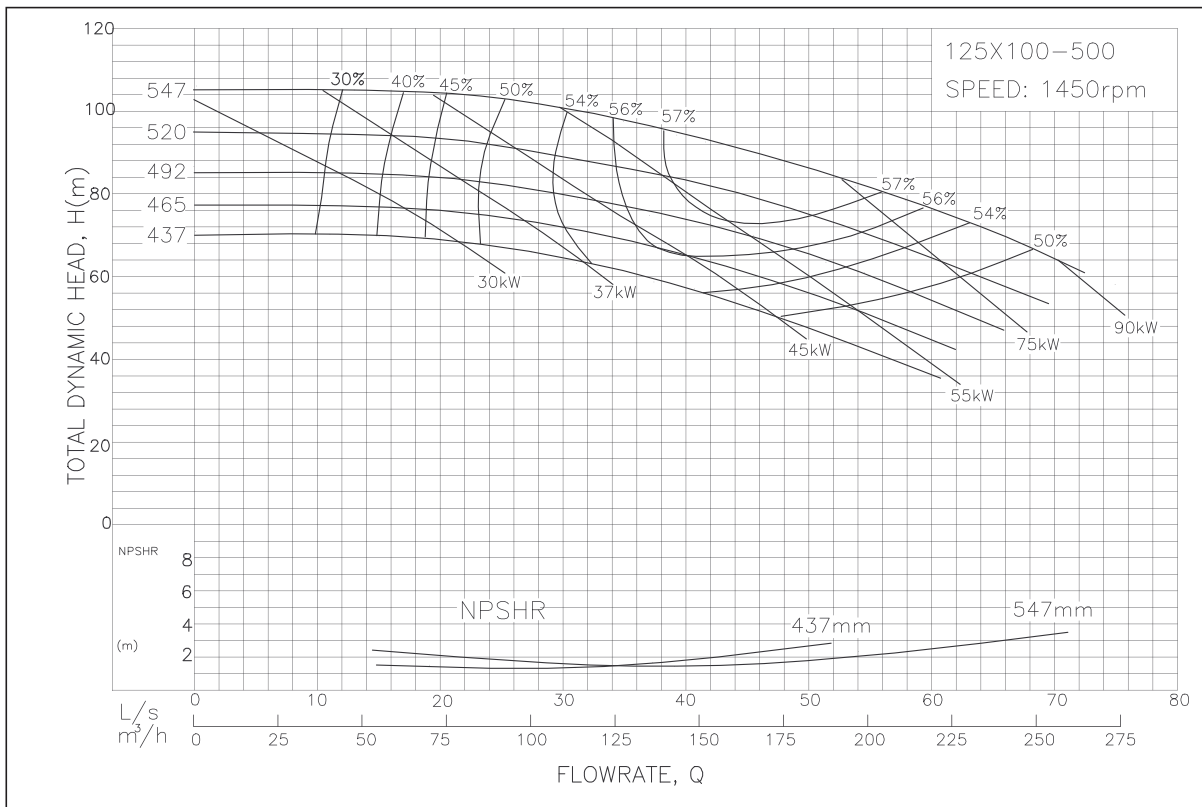

Above performance for standard construction. The efficiency correction for all stainless steel construction to be -4%.

ISO End Suction Centrifugal Pump - 150x125-250 Performance Curve

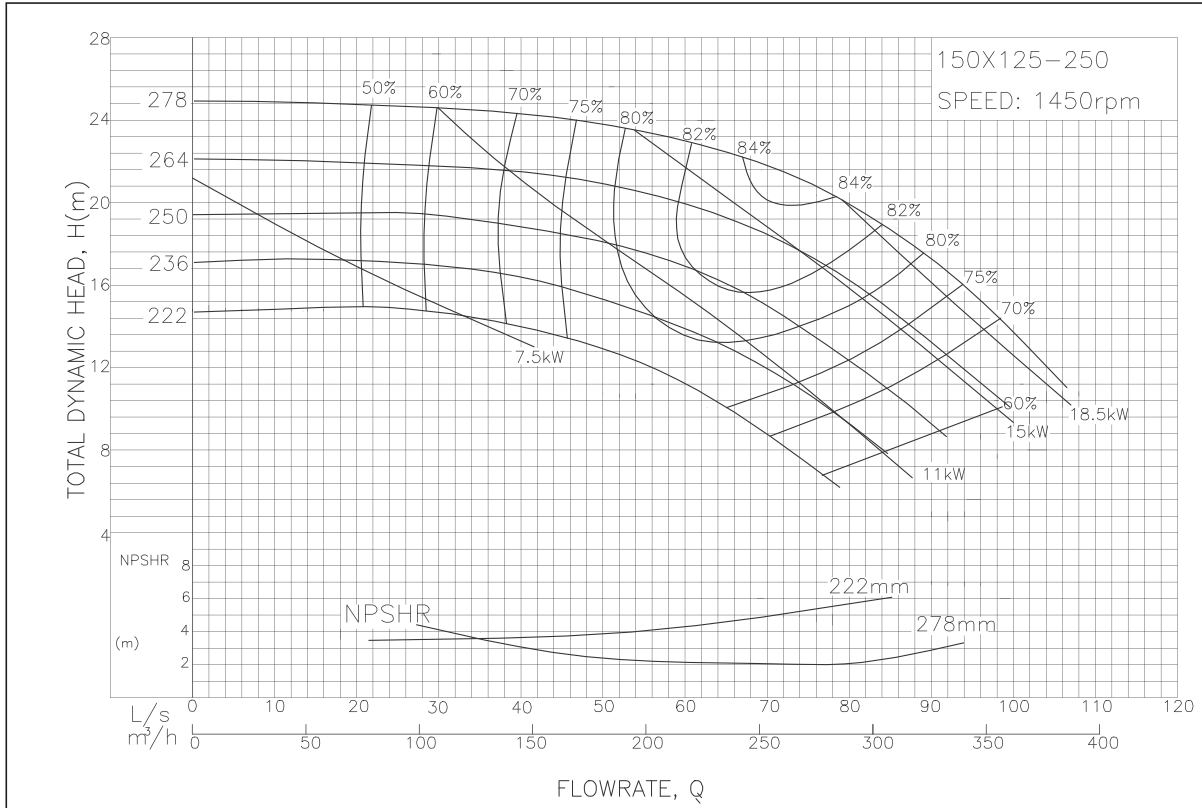

ISO End Suction Centrifugal Pump - 150x125-315 Performance Curve

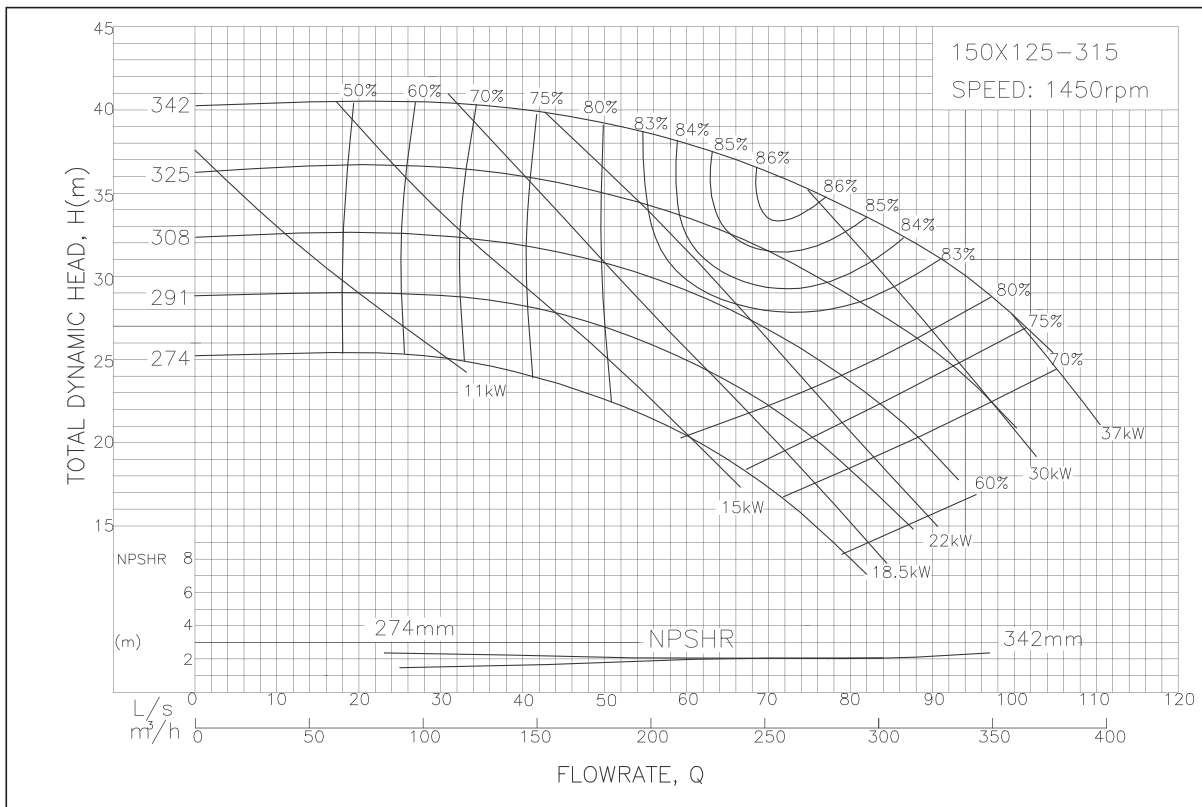

Above performance for standard construction. The efficiency correction for all stainless steel construction to be -4%.

ISO End Suction Centrifugal Pump - 150x125-400 Performance Curve (Not Available in GIS)

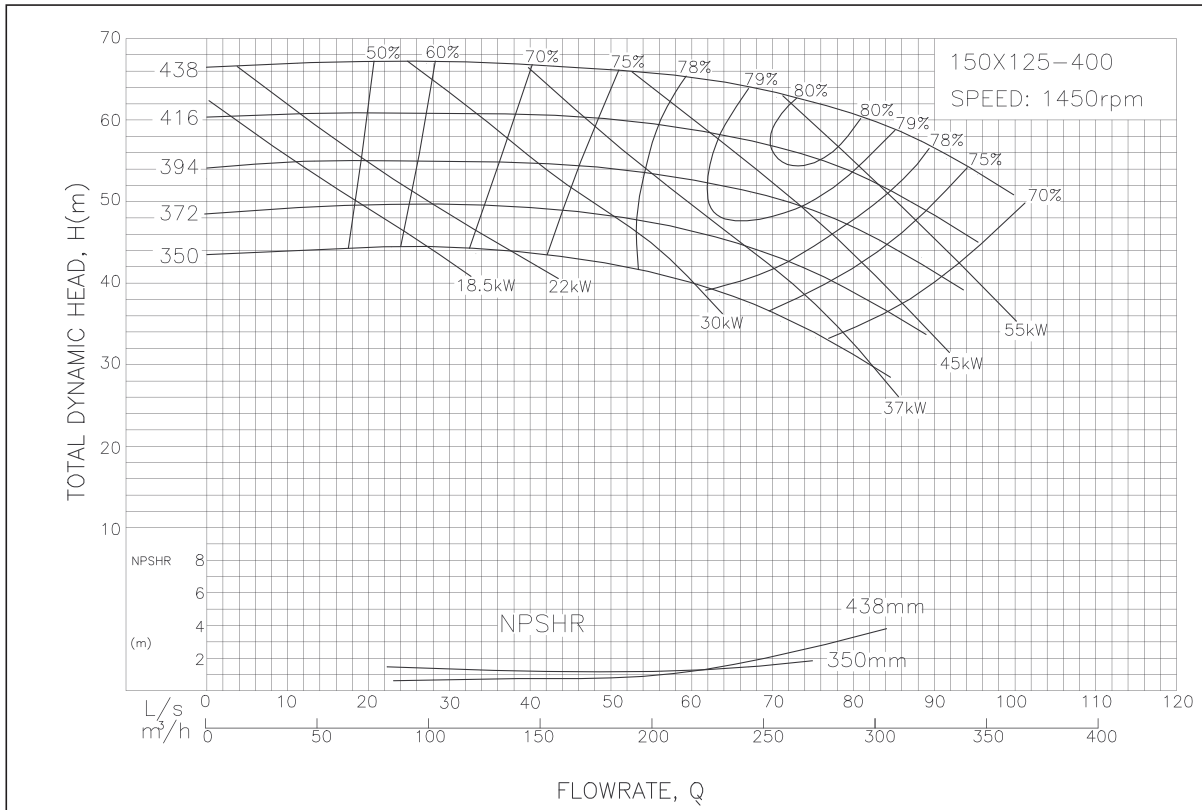

ISO End Suction Centrifugal Pump - 150x125-500 Performance Curve (Not Available in GIS)

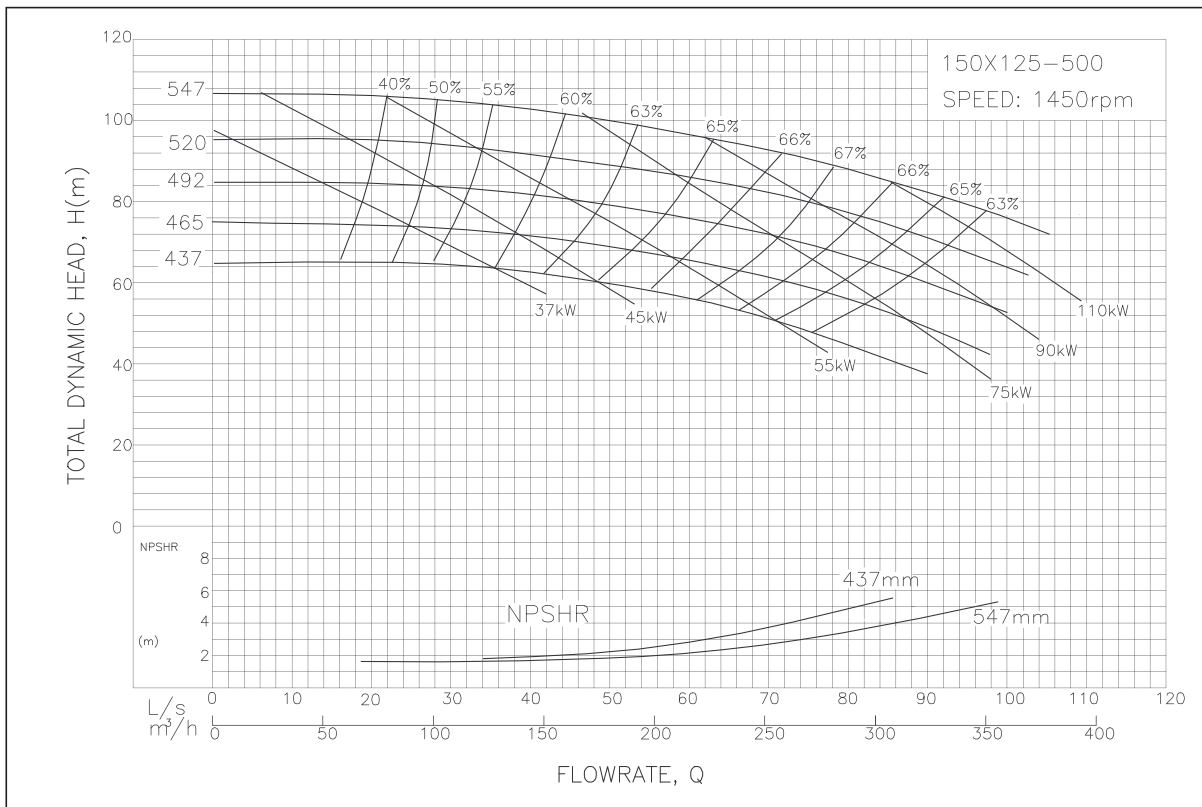

Above performance for standard construction. The efficiency correction for all stainless steel construction to be -4%.

ISO End Suction Centrifugal Pump - 200x150-315 Performance Curve (Not Available in GIS)

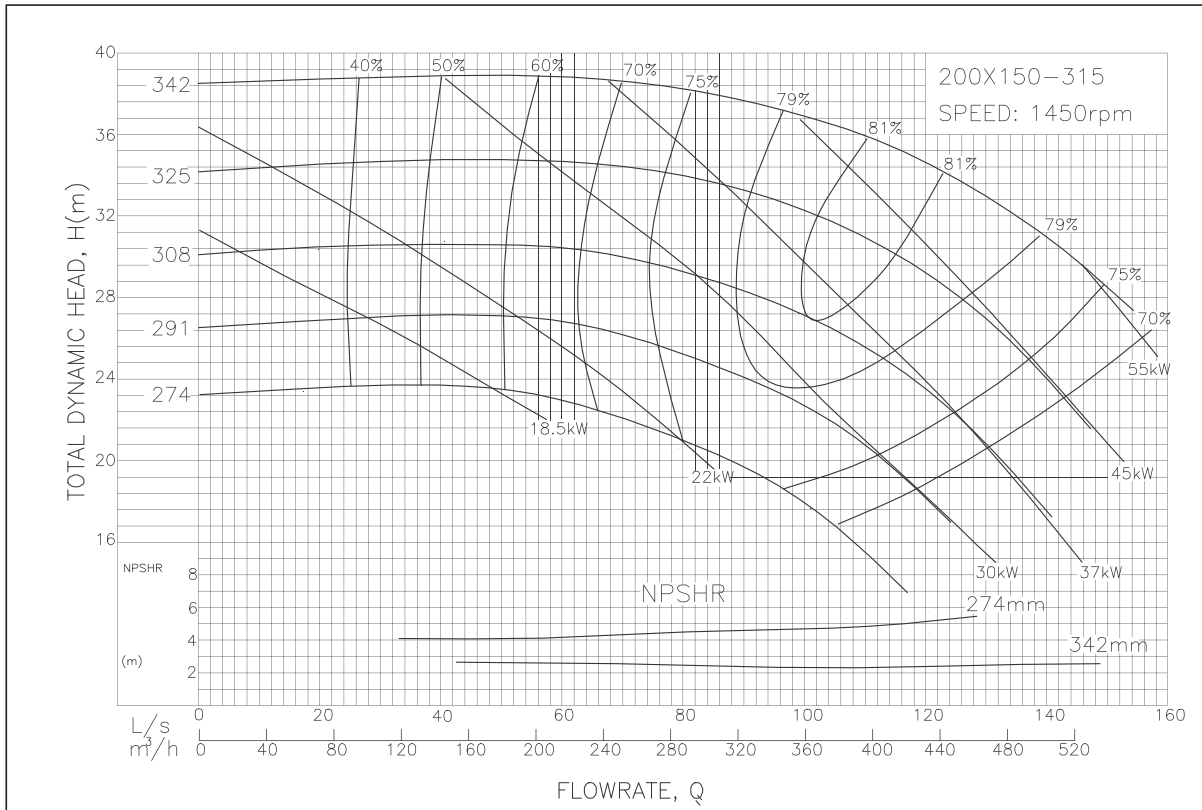

ISO End Suction Centrifugal Pump - 200x150-400 Performance Curve (Not Available in GIS)

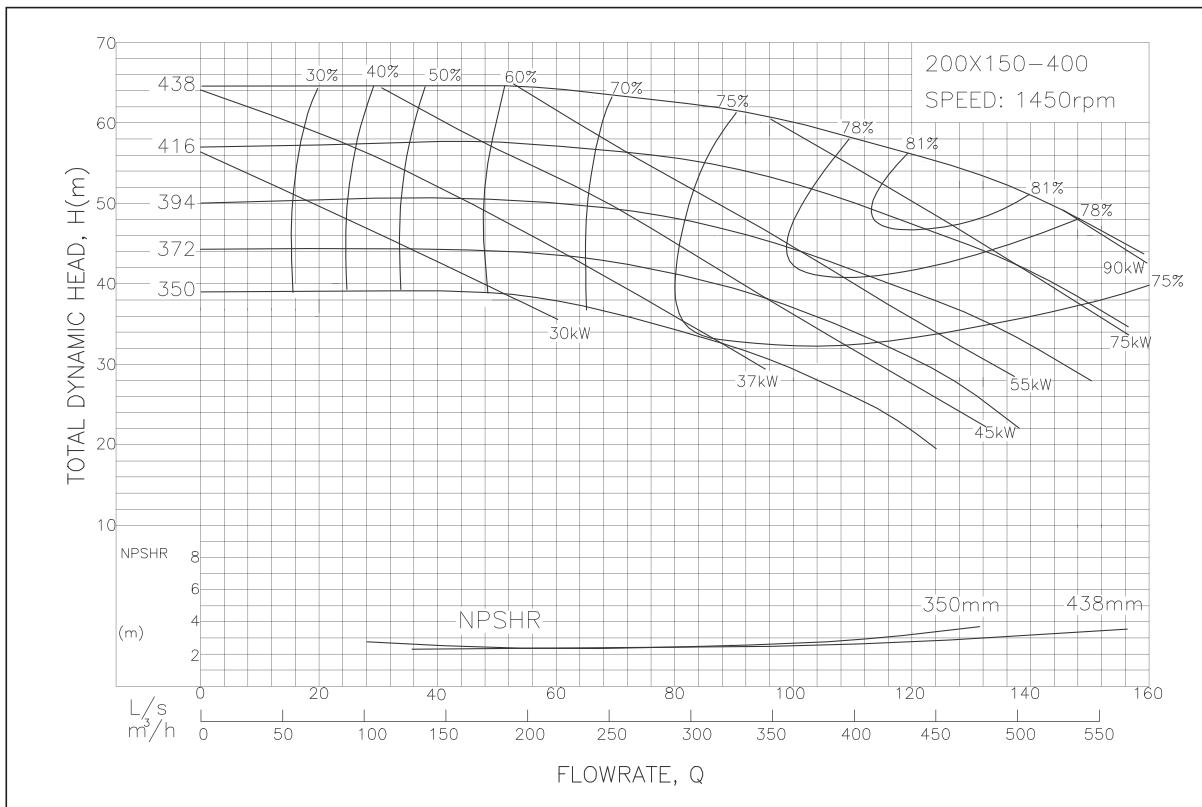

Above performance for standard construction. The efficiency correction for all stainless steel construction to be -4%.

ISO End Suction Centrifugal Pump - 200x150-500 Performance Curve (Not Available in GIS)

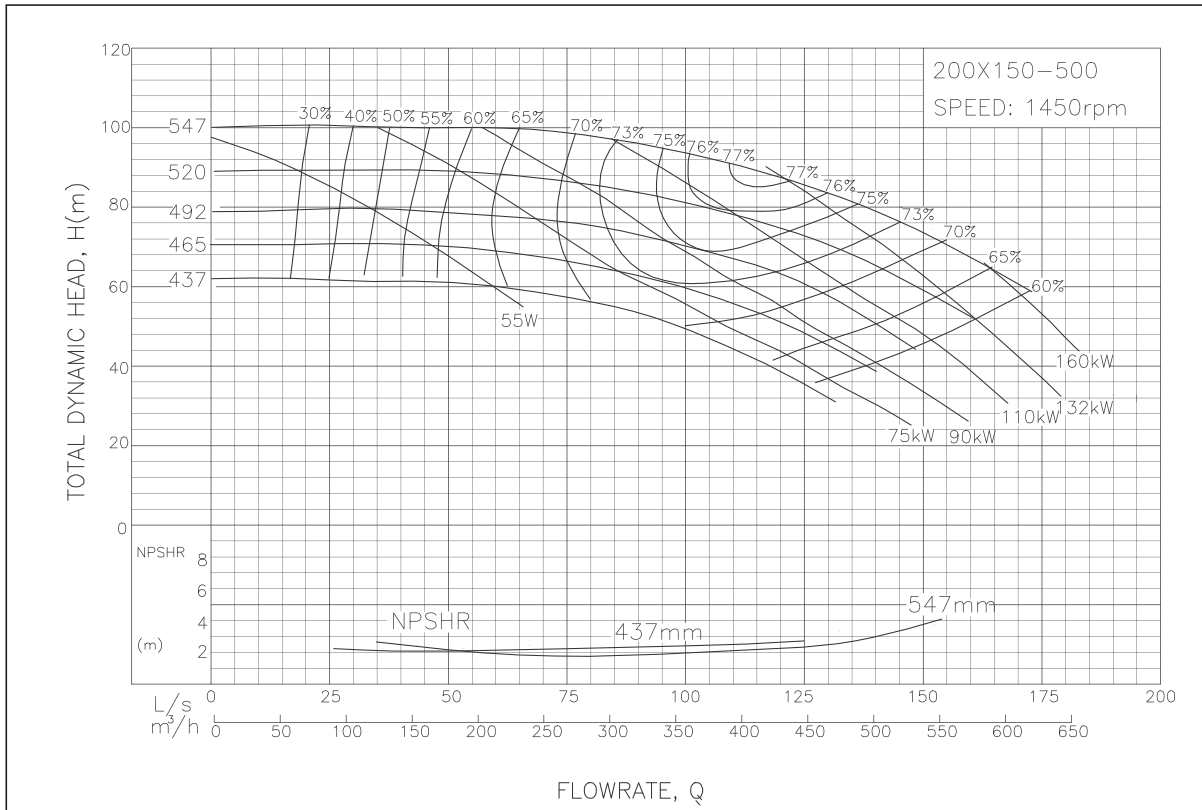

ISO End Suction Centrifugal Pump - 250x200-315 Performance Curve (Not Available in GIS)

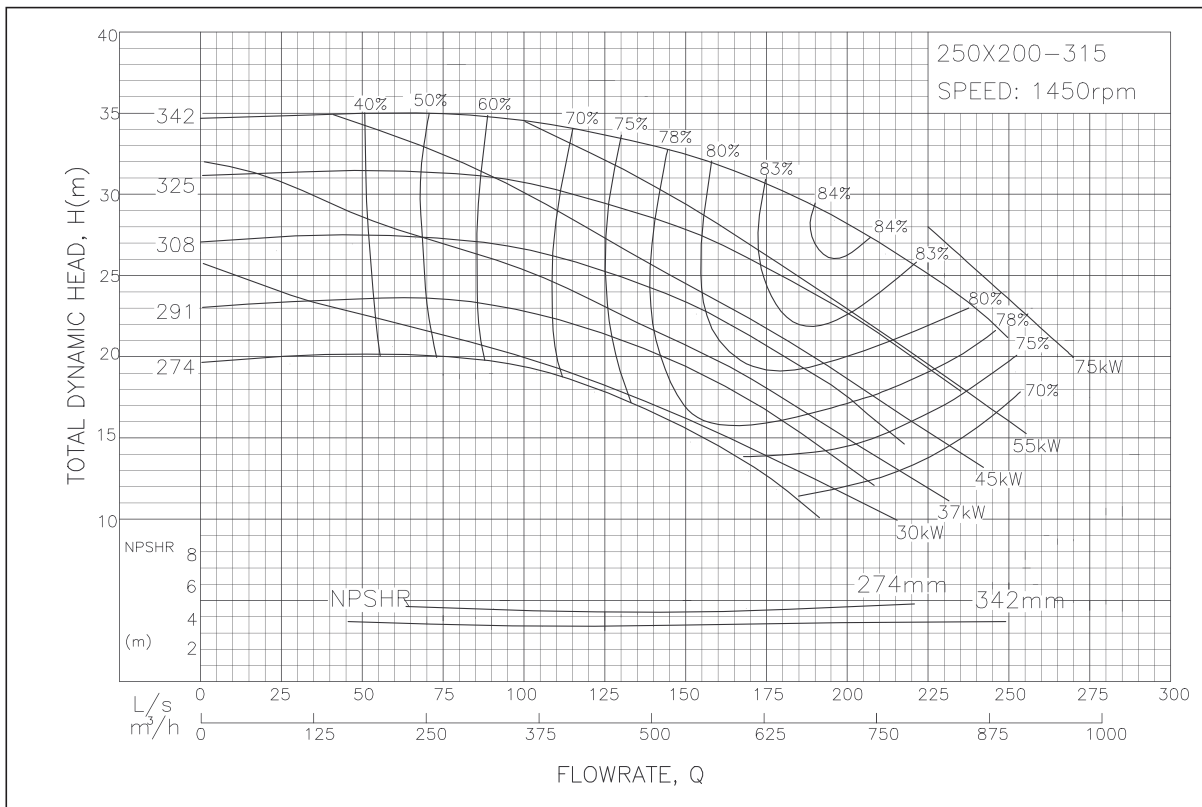

Above performance for standard construction. The efficiency correction for all stainless steel construction to be -4%.

ISO End Suction Centrifugal Pump - 250x200-400 Performance Curve (Not Available in GIS)

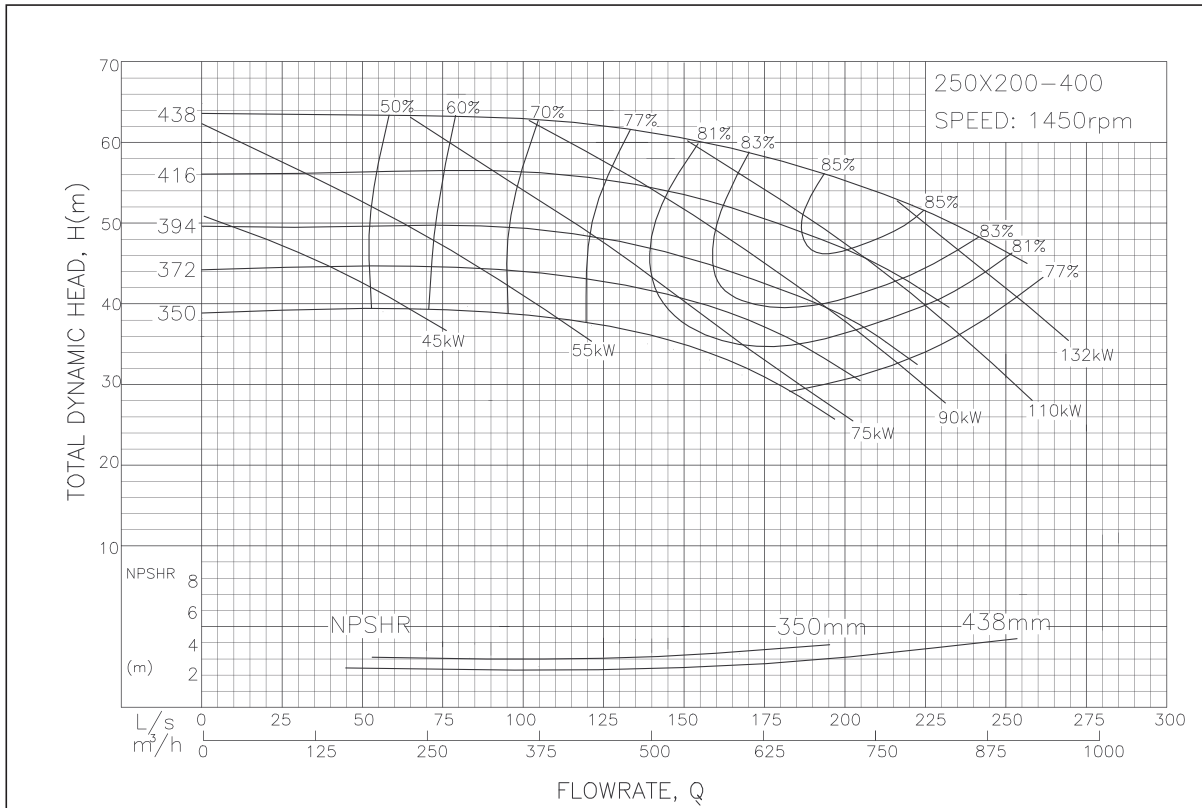

ISO End Suction Centrifugal Pump - 300x250-400 Performance Curve (Not Available in GIS)

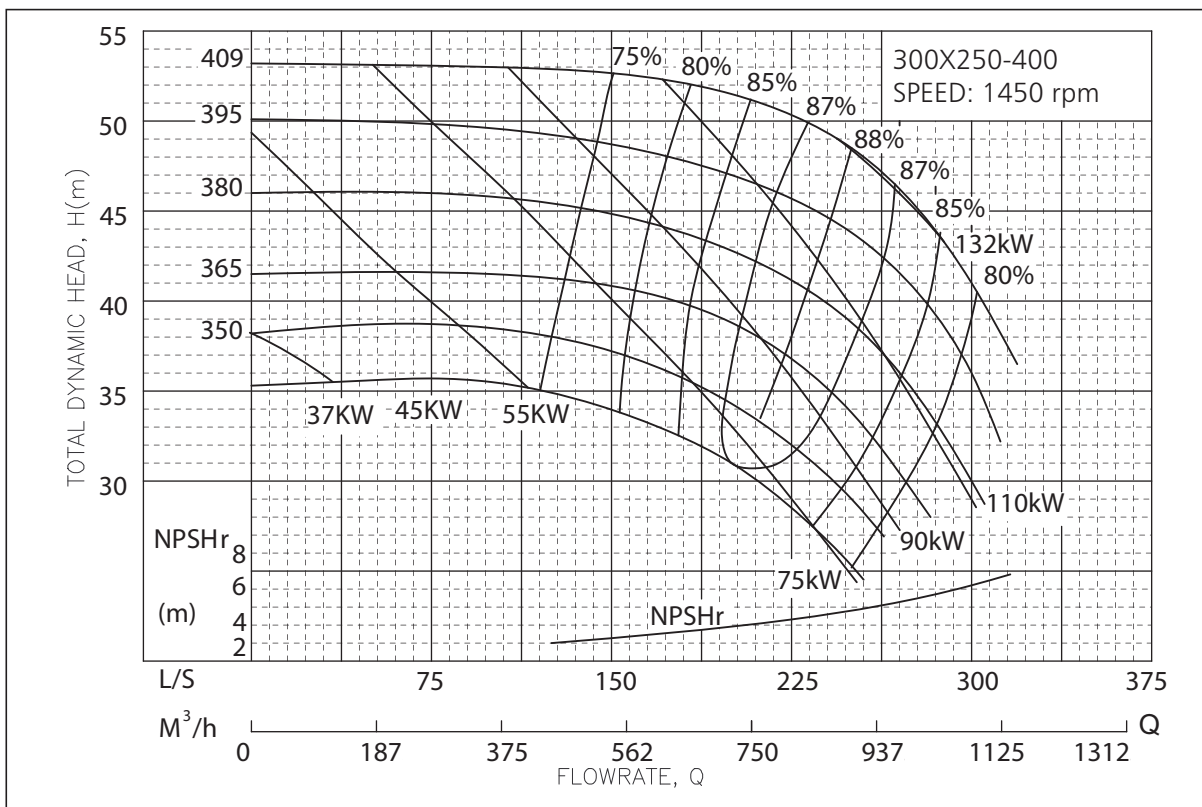

Above performance for standard construction. The efficiency correction for all stainless steel construction to be -4%.

ISO End Suction Centrifugal Pump - 300x250-315 Performance Curve (Not Available in GIS)

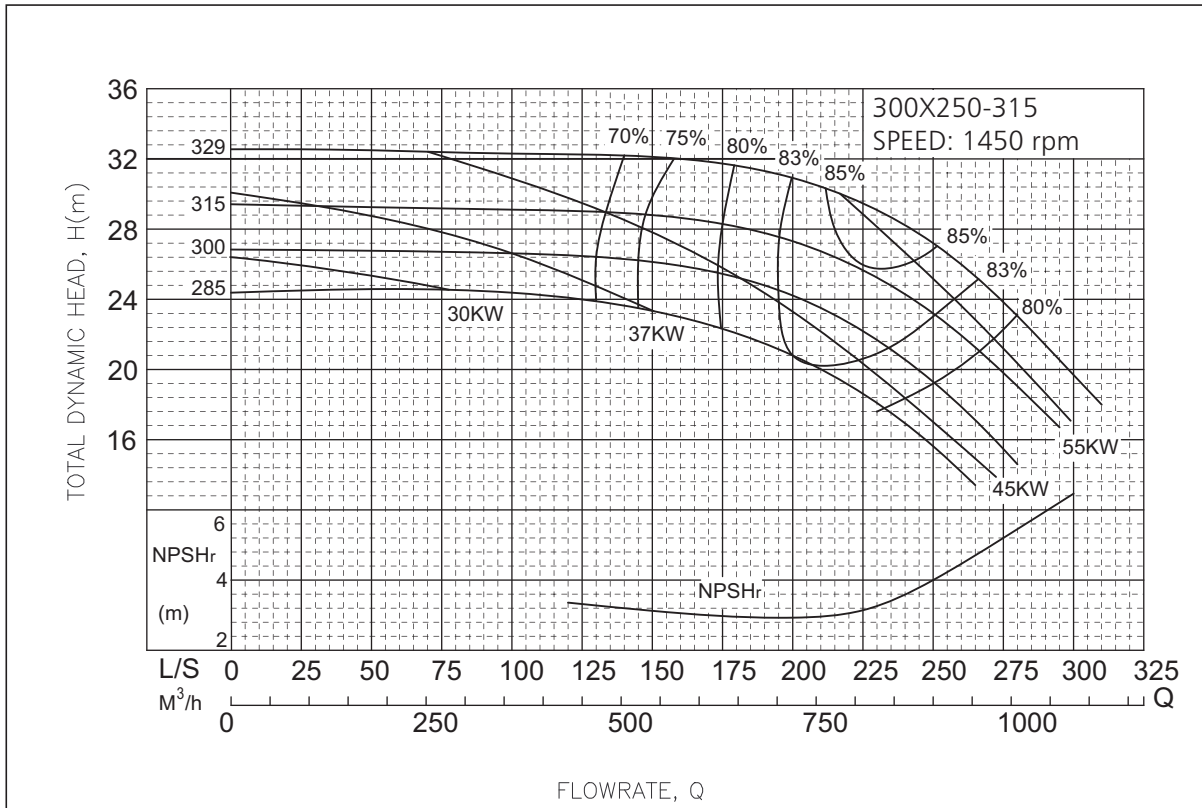

Above performance for standard construction. The efficiency correction for all stainless steel construction to be -4%.

ISO End Suction Centrifugal Pump - 400x300-460 Performance Curve (Not Available in GIS)

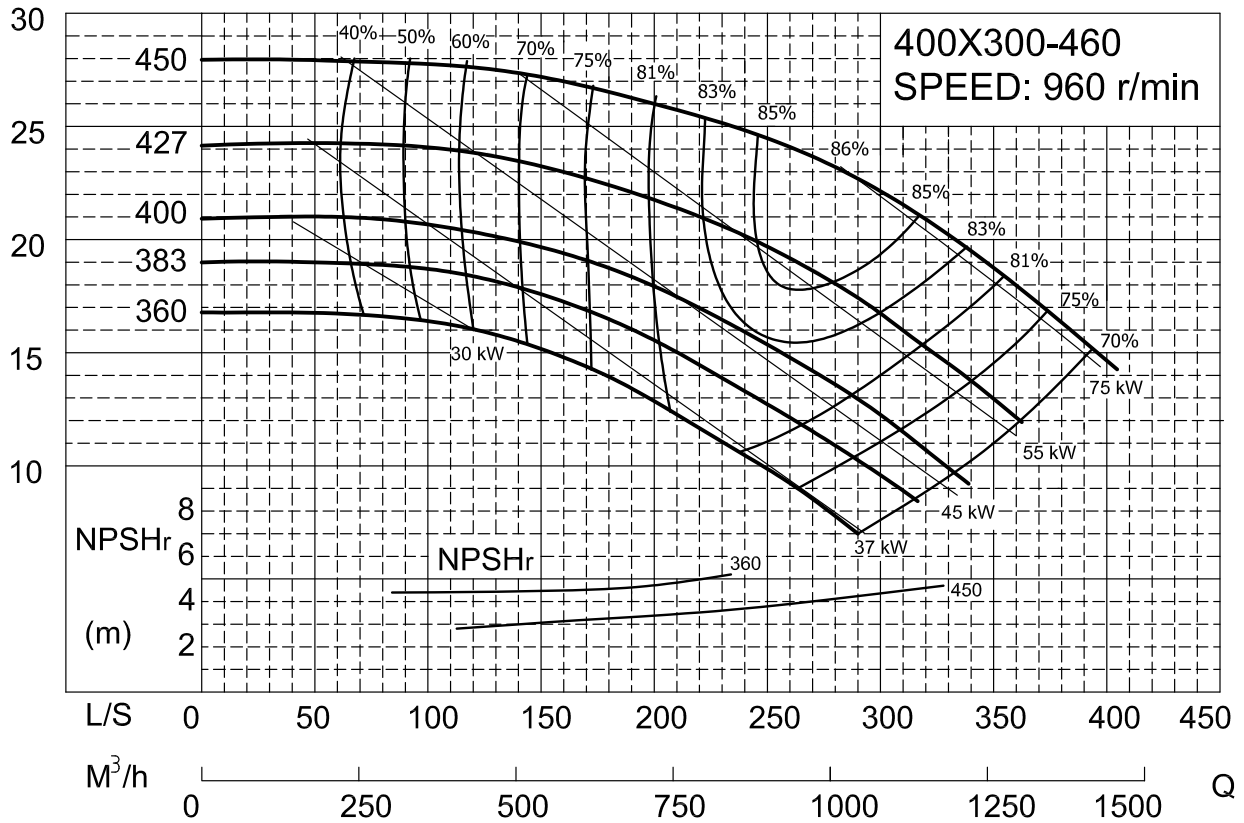

ISO End Suction Centrifugal Pump - 400x400-410 Performance Curve (Not Available in GIS)

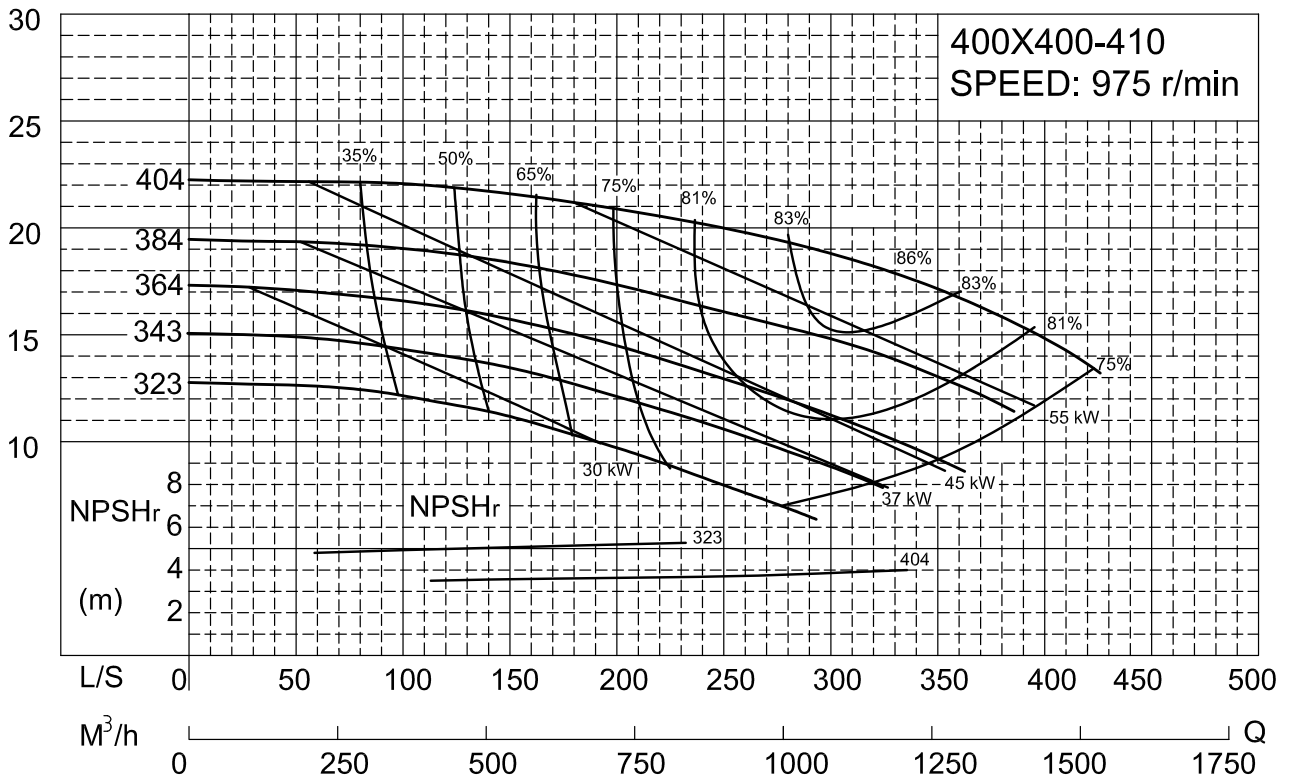

Above performance for standard construction. The efficiency correction for all stainless steel construction to be -4%.

ISO End Suction Centrifugal Pump - 400x350-480 Performance Curve (Not Available in GIS)

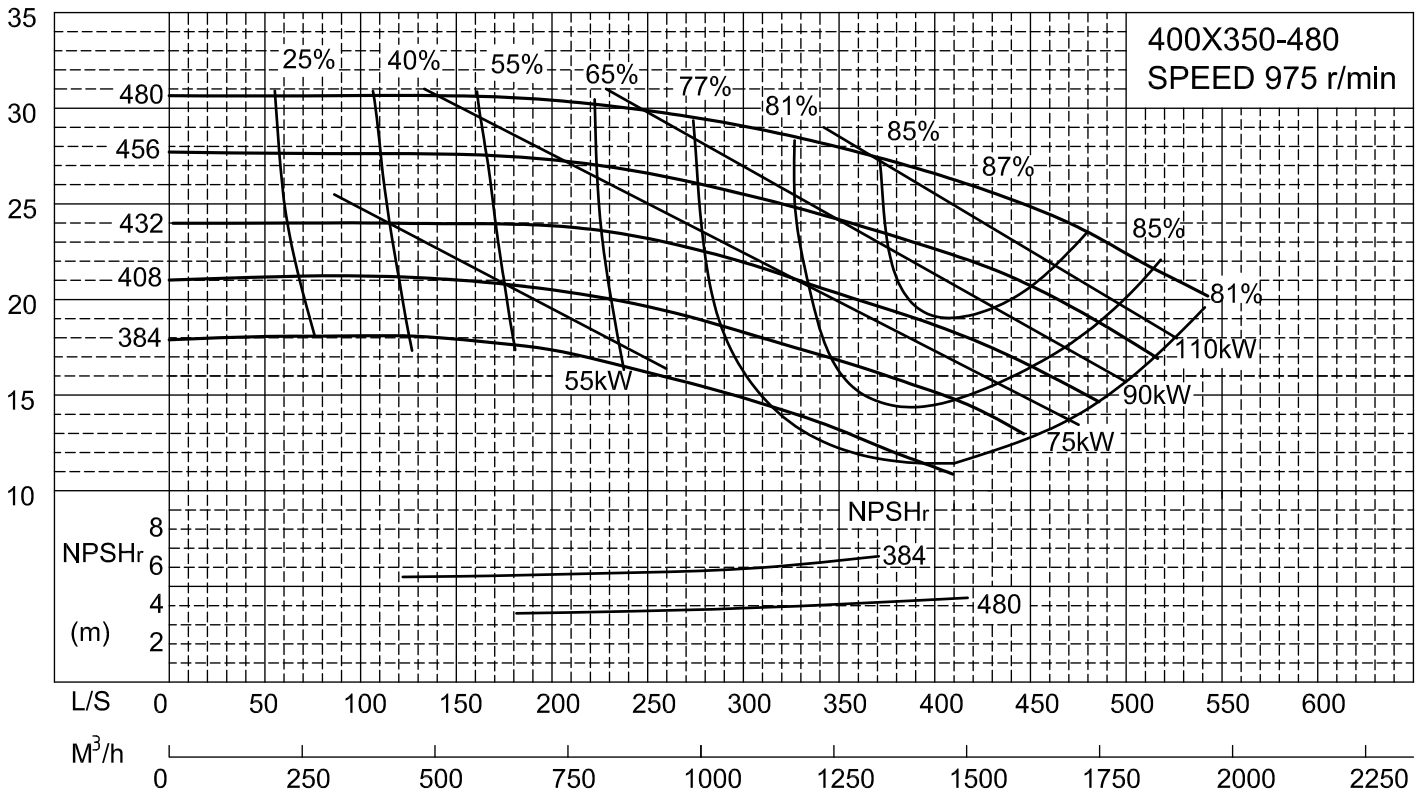

ISO End Suction Centrifugal Pump - 400x300-550 Performance Curve (Not Available in GIS)

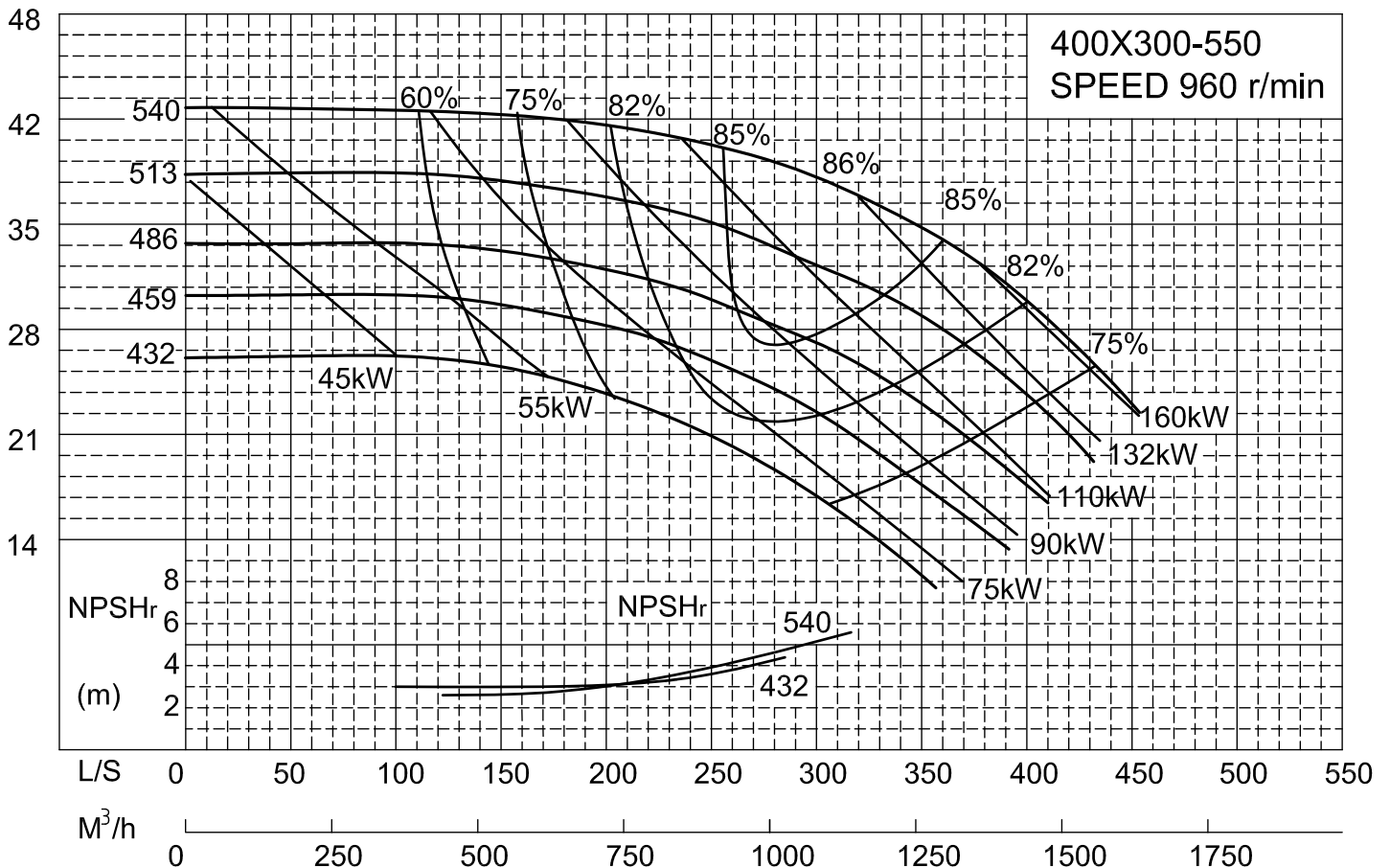

Above performance for standard construction. The efficiency correction for all stainless steel construction to be -4%.

ISO End Suction Centrifugal Pump - GISO Pump Dimensions (Bare Pump)

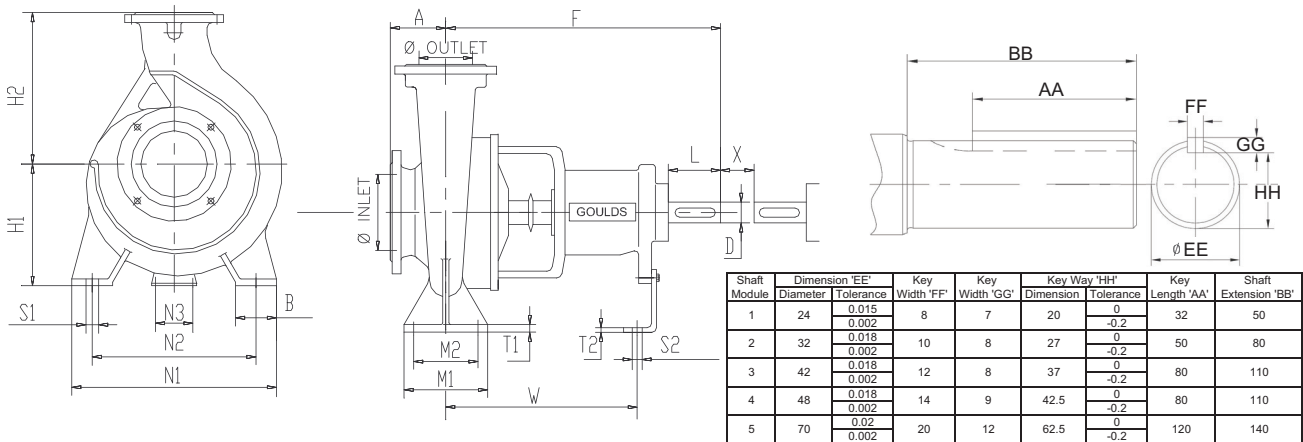

Pump			Shaft No.	Pump Dimension				Mounting Dimension							Bolt Holes		Shaft End			Gap	Weight Kg.	
Suction	Discharge	Impeller		A	F	H1	H2	B	M1	M2	N1	N2	N3	T1	T2	W	S1	S2	D			L
50	32	160	1	80	385	132	160	50	100	70	240	190	110	12	6	285	M12	M12	24	50	100	38
50	32	200	1	80	385	160	180	50	100	70	240	190	110	12	6	285	M12	M12	24	50	100	46
65	50	160	1	80	385	132	160	50	100	70	240	190	110	12	6	285	M12	M12	24	50	100	40
65	40	200	1	100	385	160	180	50	100	70	265	212	110	13	6	285	M12	M12	24	50	100	48
65	40	250	2	100	500	180	225	65	125	95	320	250	110	14	6	370	M12	M12	32	80	100	70
65	40	315	2	125	500	200	250	65	125	95	345	280	110	16	6	370	M12	M12	32	80	100	80
80	65	160	1	100	385	160	180	50	100	70	265	212	110	13	6	285	M12	M12	24	50	100	46
80	50	200	1	100	385	160	200	50	100	70	265	212	110	13	6	285	M12	M12	24	50	100	52
80	50	250	2	125	500	180	225	65	125	95	320	250	110	15	6	370	M12	M12	32	80	100	72
80	50	315	2	125	500	225	280	65	125	95	345	280	110	18	6	370	M12	M12	32	80	100	87
100	80	160	2	100	500	160	200	65	125	95	280	212	110	14	6	370	M12	M12	32	80	100	68
100	65	200	2	100	500	180	225	65	125	95	320	250	110	14	6	370	M12	M12	32	80	140	70
100	65	250	2	125	500	200	250	80	160	120	360	280	110	16	6	370	M16	M12	32	80	140	80
100	65	315	3	125	530	225	280	80	160	120	400	315	110	18	6	370	M16	M12	42	110	140	118
125	80	400	3	125	530	280	355	80	160	120	435	355	110	20	6	370	M16	M12	42	110	140	165
125	100	200	2	125	500	200	280	80	160	120	360	280	110	17	6	370	M16	M12	32	80	140	85
125	100	250	3	140	530	225	280	80	160	120	400	315	110	18	6	370	M16	M12	42	110	140	126
125	100	315	3	140	530	250	315	80	160	120	400	315	110	19	6	370	M16	M12	42	110	140	135
125	100	400	3	140	530	280	355	100	200	150	500	400	110	20	6	370	M20	M12	42	110	140	175
125	100	500	4	160	670	355	450	100	200	150	550	450	110	25	10	500	M20	M16	48	110	180	313
150	125	250	3	140	530	250	355	80	160	120	400	315	110	19	6	370	M16	M12	42	110	140	140
150	125	315	3	140	530	280	355	100	200	150	500	400	110	20	6	370	M20	M12	42	110	140	150
150	125	400	3	140	530	315	400	100	200	150	500	400	110	21	6	370	M20	M12	42	110	140	186
150	125	500	4	160	670	355	450	100	200	150	550	450	140	25	10	500	M20	M16	48	110	180	336
200	150	315	4	160	670	315	400	100	200	150	550	450	140	25	10	500	M20	M16	48	110	180	222
200	150	400	4	160	670	315	450	100	200	150	550	450	140	25	10	500	M20	M16	48	110	180	300
200	150	500	4	160	670	400	500	100	200	150	550	450	140	25	10	500	M20	M16	48	110	180	382
250	200	315	4	180	670	315	450	100	200	150	550	450	140	25	10	500	M20	M16	48	110	180	277
250	200	400	4	180	670	355	500	100	200	150	550	450	140	25	10	500	M20	M16	48	110	180	340
300	250	315	4	220	691	355	520	150	250	200	660	510	110	22	10	525	M24	M12	48	110	180	311
300	250	400	4	220	682	400	560	150	250	200	660	510	110	22	10	516	M24	M12	48	110	180	390
400	300	460	5	300	760	460	620	170	300	210	740	600	220	30	10	550	M24	M16	70	140	220	620
400	300	550	5	300	760	500	650	170	300	210	740	600	220	30	10	550	M24	M16	70	140	220	667
400	350	480	5	300	760	530	680	170	350	260	840	700	220	30	10	550	M24	M16	70	140	220	730
400	400	410	5	300	760	460	650	170	380	290	740	600	220	30	10	550	M24	M16	70	140	220	660

Remarks

- Standard flange drilling to AS 2129-1982 Table "E"
- Other drilling options available on request
- Dimensions in mm
- Gap 'x' is the minimum necessary for the withdrawal of bearing housing, back cover and impeller assembly towards drive end

ISO End Suction Centrifugal Pump - GISO Pump Dimensions (Pumpset)

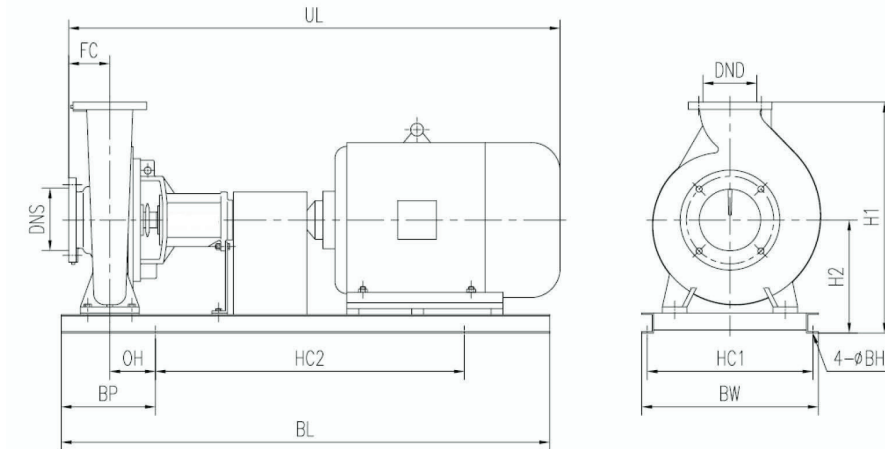

Model (2900RPM)	Motor (KW)	Motor Size	Measurement													Weight (KG)	
			H1	H2	HC1	HC2	BW	BL	BP	BH	OH	UL	FC	DNS	DND	With Motor	Without Motor
GISO 50-32-160	3.0	100L	369	209	310	450	350	750	150	14	93	863	80	50	32	118	82
	4.0	112M	369	209	310	450	350	760	155	14	99	883	80	50	32	127	83
	5.5	132S	369	209	310	500	350	810	155	14	98	960	80	50	32	144	79
GISO 50-32-200	5.5	132S	415	235	310	500	350	810	155	14	98	960	80	50	32	189	124
	7.5	132S	415	235	310	500	350	810	155	14	98	960	80	50	32	194	126
	11.0	160M	432	252	350	580	390	930	175	14	117	1094	80	50	32	246	128
GISO 65-40-200	7.5	132S	415	235	310	500	350	810	155	14	98	980	100	65	40	207	139
	11.0	160M	432	252	350	580	390	930	175	14	117	1114	100	65	40	258	140
	15.0	160M	432	252	350	580	390	930	175	14	117	1114	100	65	40	269	140
GISO 65-40-250	11.0	160M	520	295	400	750	440	1060	155	18	83	1229	100	65	40	276	158
	15.0	160M	520	295	400	750	440	1060	155	18	83	1229	100	65	40	287	158
	18.5	160L	520	295	400	750	440	1100	175	18	105	1274	100	65	40	308	161
	22.0	180M	520	295	400	750	440	1115	185	18	114	1229	100	65	40	337	151
	30.0	200L	560	335	400	780	450	1190	205	22	134	1401	100	65	40	405	163
GISO 65-40-315	22.0	180M	565	315	400	750	440	1115	185	18	114	1321	125	65	40	374	188
	30.0	200L	585	335	400	780	450	1190	205	22	134	1426	125	65	40	442	200
	37.0	200L	585	335	400	780	450	1190	205	22	134	1426	125	65	40	462	199
	45.0	225M	585	335	450	800	490	1225	215	22	143	1471	125	65	40	540	213
GISO 65-50-160	4.0	100L	369	209	310	450	350	760	155	14	99	883	80	65	50	93	49
	5.5	132S	369	209	310	500	350	810	155	14	98	960	80	65	50	110	45
	7.5	132S	369	209	310	500	350	810	155	14	98	960	80	65	50	116	48
GISO 80-50-200	11.0	160M	452	252	350	580	390	930	175	14	117	1114	100	80	50	272	154
	15.0	160M	452	252	350	580	390	930	175	14	117	1114	100	80	50	282	153
	18.5	160L	452	252	350	580	390	980	200	14	140	1159	100	80	50	303	156
	22.0	180M	475	275	350	580	390	990	205	14	145	1181	100	80	50	333	147
GISO 80-50-250	22.0	180M	520	295	400	750	440	1115	185	18	114	1321	125	80	50	354	168
	30.0	200L	560	335	400	780	450	1190	205	22	134	1426	125	80	50	422	180
	37.0	200L	560	335	400	780	450	1190	205	22	134	1426	125	80	50	442	179
	45.0	225M	585	360	450	800	490	1225	215	22	143	1471	125	80	50	520	193
GISO 80-50-315	30.0	200L	645	365	400	780	450	1190	205	22	134	1426	125	80	50	513	271
	37.0	200L	645	365	400	780	450	1190	205	22	134	1426	125	80	50	559	296
	45.0	225M	640	360	450	800	490	1225	215	22	143	1471	125	80	50	636	309
	55.0	250M	690	410	500	870	550	1320	225	28	154	1583	125	80	50	701	283
	75.0	280S	720	440	550	880	600	1370	245	28	173	1655	125	80	50	821	260

Remarks

1. Standard flange drilling to AS 2129-1982 Table "E"
2. Other drilling options available on request
3. Dimensions subject to change without notice. Do not use for construction purposes.
4. Motor dimensions and data may vary dependent on motor type

ISO End Suction Centrifugal Pump - GISO Pump Dimensions (Pumpset)

Model (2900RPM)	Motor (KW)	Motor Size	Measurement													Weight (KG)	
			H1	H2	HC1	HC2	BW	BL	BP	BH	OH	UL	FC	DNS	DND	With Motor	Without Motor
GISO 80-65-160	5.5	132S	415	235	310	500	350	810	155	14	98	980	100	80	65	168	103
	7.5	132S	415	235	310	500	350	810	155	14	98	980	100	80	65	173	105
	11.0	160M	432	252	350	580	390	930	175	14	117	1114	100	80	65	225	107
	15.0	160M	432	252	350	580	390	930	175	14	117	1114	100	80	65	235	106
GISO 100-65-200	18.5	160L	520	295	400	750	440	1100	175	18	105	1274	100	100	65	318	171
	22.0	180M	520	295	400	750	440	1115	185	18	114	1296	100	100	65	348	162
	30.0	200L	560	335	400	780	450	1190	205	22	134	1401	100	100	65	416	174
	37.0	200L	560	335	400	780	450	1190	205	22	134	1401	100	100	65	436	173
GISO 100-65-250	30.0	200L	585	335	400	780	450	1210	215	22	126	1426	125	100	65	433	191
	37.0	200L	585	335	400	780	450	1210	215	22	126	1426	125	100	65	453	190
	45.0	225M	610	360	450	800	490	1240	220	22	131	1471	125	100	65	530	203
	55.0	250M	660	410	500	870	550	1340	235	28	145	1583	125	100	65	595	177
	75.0	280S	690	440	550	880	600	1390	255	28	165	1655	125	100	65	715	154
GISO 100-65-315	55.0	250M	690	410	500	870	550	1370	250	28	159	1613	125	100	65	615	197
	75.0	280S	720	440	550	880	600	1470	295	28	205	1685	125	100	65	735	174
	90.0	280M	720	440	550	880	600	1470	295	28	205	1735	125	100	65	794	200
	110.0	315S	760	480	620	950	670	1510	280	28	187	1930	125	100	65	1161	149
GISO 100-80-160	11.0	160M	475	275	400	750	440	1060	155	18	83	1229	100	100	80	208	90
	15.0	160M	475	275	400	750	440	1060	155	18	83	1229	100	100	80	218	89
	18.5	160L	475	275	400	750	440	1100	175	18	105	1274	100	100	80	239	92
	22.0	180M	475	275	400	750	440	1115	185	18	114	1296	100	100	80	308	122
GISO 125-100-200	30.0	200L	615	335	400	780	450	1210	215	22	126	1426	125	125	100	432	190
	37.0	200L	615	335	400	780	450	1210	215	22	126	1426	125	125	100	452	189
	45.0	225M	640	360	450	800	490	1240	220	22	131	1471	125	125	100	529	202
	55.0	250M	690	410	500	870	550	1340	235	28	145	1583	125	125	100	594	176
	75.0	280S	720	440	550	880	600	1390	255	28	165	1655	125	125	100	714	153
GISO 125-100-250	55.0	250M	690	410	500	870	550	1370	250	28	159	1628	140	125	100	672	254
	75.0	280S	720	440	550	880	600	1470	295	28	205	1700	140	125	100	747	186
	90.0	280M	720	440	550	880	600	1470	295	28	205	1750	140	125	100	805	211
	110.0	315S	760	480	620	950	670	1510	280	28	187	1945	140	125	100	1176	164
GISO 125-100-315	90.0	280M	755	440	550	880	600	1470	295	28	205	1750	140	125	100	840	246
	110.0	315S	795	480	620	950	670	1510	280	28	187	1945	140	125	100	1208	196
	132.0	315M	795	480	620	950	670	1590	320	28	231	2015	140	125	100	1313	246
	160.0	315L	795	480	620	950	670	1610	330	28	244	2015	140	125	100	1376	188

Remarks

1. Standard flange drilling to AS 2129-1982 Table "E"
2. Other drilling options available on request
3. Dimensions subject to change without notice. Do not use for construction purposes.
4. Motor dimensions and data may vary dependent on motor type

ISO End Suction Centrifugal Pump - GISO Pump Dimensions (Pumpset)

Model (1450RPM)	Motor (KW)	Motor Size	Measurement													Weight (KG)	
			H1	H2	HC1	HC2	BW	BL	BP	BH	OH	UL	FC	DNS	DND	With Motor	Without Motor
GISO 125-80-400	15.0	160L	755	400	440	750	480	1150	200	18	112	1329	125	125	80	491	345
	18.5	180M	755	400	440	750	480	1200	225	18	135	1351	125	125	80	516	332
	22.0	180L	755	400	440	750	480	1200	225	18	135	1391	125	125	80	532	333
	30.0	200L	775	420	500	820	540	1240	210	22	120	1456	125	125	80	595	340
	37.0	225S	795	440	500	820	550	1280	230	28	140	1503	125	125	80	652	336
GISO 125-100-200	4.0	112M	575	295	350	580	390	910	165	14	76	1043	125	125	100	282	234
	5.5	132S	595	315	400	630	440	990	180	18	94	1120	125	125	100	298	231
	7.5	132M	595	315	400	630	440	990	180	18	94	1160	125	125	100	306	226
GISO 125-100-250	7.5	132M	620	340	400	630	440	1030	200	18	111	1205	140	125	100	294	214
	11.0	160M	620	340	400	750	440	1160	205	18	118	1299	140	125	100	339	215
	15.0	160L	620	340	400	750	440	1160	205	18	118	1344	140	125	100	361	215
GISO 125-100-315	11.0	160M	620	365	400	750	440	1160	205	18	118	1299	140	125	100	362	238
	15.0	160L	680	365	400	750	440	1160	205	18	118	1344	140	125	100	334	188
	18.5	180M	680	365	400	750	440	1200	225	18	137	1366	140	125	100	419	235
	22.0	180L	680	365	400	750	440	1200	225	18	137	1406	140	125	100	438	239
	30.0	200L	705	390	500	820	340	1240	210	22	120	1471	140	125	100	509	254
GISO 125-100-400	18.5	180M	775	420	500	820	340	1220	200	22	90	1366	140	125	100	510	326
	22.0	180L	775	420	500	820	340	1220	200	22	90	1406	140	125	100	523	324
	30.0	200L	775	420	500	820	340	1260	230	22	110	1471	140	125	100	593	338
	37.0	225S	795	440	500	820	330	1325	250	28	140	1518	140	125	100	646	330
	45.0	225M	795	440	500	820	330	1325	250	28	140	1543	140	125	100	683	329
GISO 125-100-500	45.0	225M	965	515	550	880	600	1465	300	28	190	1703	160	125	100	694	340
	55.0	250M	965	515	550	950	600	1530	290	28	180	1790	160	125	100	710	286
	75.0	280S	970	520	550	1050	600	1635	300	28	190	1865	160	125	100	798	237
	90.0	280M	970	520	550	1050	600	1635	300	28	190	1915	160	125	100	859	199
GISO 150-125-250	11.0	160M	720	365	400	750	440	1160	205	18	118	1299	140	150	125	331	207
	15.0	160L	720	365	400	750	440	1160	205	18	118	1344	140	150	125	373	227
	18.5	180M	720	365	400	750	440	1200	225	18	137	1366	140	150	125	407	223
	22.0	180L	720	365	400	750	440	1200	225	18	137	1406	140	150	125	426	227
GISO 150-125-315	18.5	180M	775	420	500	820	540	1220	200	22	90	1366	140	150	125	512	328
	22.0	180L	775	420	500	820	540	1220	200	22	90	1406	140	150	125	496	297
	30.0	200L	775	420	500	820	540	1260	220	22	110	1471	140	150	125	570	315
	37.0	225S	795	440	500	820	550	1325	230	28	140	1518	140	150	125	627	311
GISO 150-125-400	37.0	225S	875	475	500	820	550	1325	230	28	140	1518	140	150	125	687	371
	45	225M	875	475	500	820	550	1325	230	28	140	1543	140	150	125	715	361
	55	250M	875	475	500	870	600	1390	260	28	150	1628	140	150	125	785	361
	75	280S	875	475	550	880	600	1440	280	28	172	1705	140	150	125	939	378
GISO 150-125-500	75	280S	970	520	550	1050	600	1635	300	28	190	1865	160	150	125	954	393
	90	280M	970	520	550	1050	600	1635	300	28	190	1915	160	150	125	1015	355
	110	315S	965	515	630	1140	680	1705	285	28	175	2140	160	150	125	1170	147
	132	315L	965	515	630	1140	680	1790	325	28	215	2140	160	150	125	1475	364
GISO 200-150-315	30	200L	875	475	550	880	600	1400	260	28	150	1631	160	200	150	600	345
	37	225S	875	475	550	880	600	1465	300	28	190	1678	160	200	150	671	355
	45	225M	875	475	550	880	600	1465	300	28	190	1703	160	200	150	708	354
	55	250M	875	475	550	1080	600	1530	240	28	130	1790	160	200	150	789	365
	75	280S	875	475	550	1080	600	1635	300	28	190	1865	160	200	150	877	316

Remarks

1. Standard flange drilling to AS 2129-1982 Table "E"
2. Other drilling options available on request
3. Dimensions subject to change without notice. Do not use for construction purposes.
4. Motor dimensions and data may vary dependent on motor type

ISO End Suction Centrifugal Pump - GISO Pump Dimensions (Pumpset)

Model (1450RPM)	Motor (KW)	Motor Size	Measurement													Weight (KG)	
			H1	H2	HC1	HC2	BW	BL	BP	BH	OH	UL	FC	DNS	DND	With Motor	Without Motor
GISO 50-32-160	0.55	80M	367	207	270	430	310	675	125	14	67	771	80	50	32	97	79
	0.75	80M	367	207	270	430	310	675	125	14	67	771	80	50	32	98	80
GISO 50-32-200	0.55	80M	415	235	270	430	310	675	125	14	67	771	80	50	32	99	81
	0.75	80M	415	235	270	430	310	675	125	14	67	771	80	50	32	100	82
	1.1	90S	415	235	270	430	310	720	145	14	86	796	80	50	32	104	80
	1.5	90L	415	235	270	430	310	720	145	14	86	821	80	50	32	108	78
GISO 65-40-200	1.1	90S	415	235	270	430	310	720	145	14	86	816	100	7S	40	111	87
	1.5	90L	415	235	270	430	310	720	145	14	86	841	100	65	40	121	91
	2.2	100L	415	235	270	430	310	750	160	14	103	883	100	65	40	130	93
GISO 65-40-250	1.5	90L	480	255	310	500	350	850	175	14	102	956	100	65	40	118	88
	2.2	100L	500	275	350	580	390	880	150	14	79	998	100	65	40	124	87
	3.0	100L	500	275	350	580	390	880	150	14	79	998	100	65	40	142	103
	4.0	112M	500	275	350	580	390	890	155	14	85	1018	100	65	40	151	103
GISO 65-40-315	3.0	100L	545	295	350	580	390	880	150	14	79	1023	125	65	40	213	174
	4.0	112M	545	295	350	580	390	890	155	14	85	1043	125	65	40	223	175
	5.5	132S	565	315	400	630	440	940	155	18	85	1120	125	65	40	238	171
GISO 65-50-160	0.55	80M	367	207	270	430	310	675	125	14	67	771	80	65	50	103	85
	0.75	80M	367	207	270	430	310	675	125	14	67	771	80	65	50	106	88
	1.1	90S	367	207	270	430	310	690	130	14	73	796	80	65	50	108	84
GISO 80-50-200	1.5	90L	435	235	270	430	310	720	145	14	86	841	100	80	50	159	129
	2.2	100L	435	235	270	430	310	750	160	14	103	883	100	80	50	170	133
	3.0	100L	435	235	270	430	310	750	160	14	103	883	100	80	50	187	148
GISO 80-50-250	3.0	100L	500	275	350	580	390	880	150	14	79	1023	125	80	50	234	195
	4.0	112M	500	275	350	580	390	890	155	14	85	1043	125	80	50	243	195
	5.5	132S	520	295	400	630	440	940	155	18	85	1120	125	80	50	258	191
GISO 80-50-315	4.0	112M	600	320	350	580	390	890	155	14	85	1043	125	80	50	234	186
	5.5	132S	620	340	400	630	440	980	175	18	103	1120	125	80	50	246	179
	7.5	132M	620	340	400	630	440	980	175	18	103	1160	125	80	50	257	177
GISO 80-65-160	0.75	80M	415	235	270	430	310	675	125	14	125	791	100	80	65	145	127
	1.1	90S	415	235	270	430	310	720	145	14	86	816	100	80	65	149	125
	1.5	90L	415	235	270	430	310	720	145	14	86	841	100	80	65	153	123
GISO 100-65-200	3.0	100L	500	275	350	580	390	880	150	14	79	998	100	100	65	207	168
	4.0	112M	500	275	350	580	390	890	155	14	85	1018	100	100	65	216	168
	5.5	132S	520	295	400	630	440	940	155	18	85	1095	100	100	65	232	165
GISO 100-65-250	4.0	112M	545	295	350	580	390	910	165	14	76	1043	125	100	65	276	228
	5.5	132S	565	315	400	630	440	990	180	18	94	1120	125	100	65	292	225
	7.5	132M	565	315	400	630	440	990	180	18	94	1160	125	100	65	306	226
GISO 100-65-315	7.5	132M	620	340	400	630	440	1030	200	18	111	1190	125	100	65	282	202
	11.0	160M	620	340	400	750	440	1160	205	18	118	1284	125	100	65	3288	3164
	15.0	160L	620	340	400	750	440	1160	205	18	118	1329	125	100	65	350	204
GISO 100-80-160	1.5	90L	435	235	310	500	350	850	175	14	102	956	100	100	80	294	264
	2.2	100L	455	255	350	580	390	880	150	14	79	998	100	100	80	301	264
	3.0	100L	455	255	350	580	390	880	150	14	79	998	100	100	80	306	267

Remarks

1. Standard flange drilling to AS 2129-1982 Table "E"
2. Other drilling options available on request
3. Dimensions subject to change without notice. Do not use for construction purposes.
4. Motor dimensions and data may vary dependent on motor type

ISO End Suction Centrifugal Pump - GISO Pump Dimensions (Pumpset)

Model (1450RPM)	Motor (KW)	Motor Size	Measurement													Weight (KG)	
			H1	H2	HC1	HC2	BW	BL	BP	BH	OH	UL	FC	DNS	DND	With Motor	Without Motor
GISO 200-150-400	45.0	225M	925	475	550	880	600	1465	300	28	190	1703	160	200	150	851	497
	55.0	250M	925	475	550	1060	600	1530	240	28	130	1790	160	200	150	866	442
	75.0	280S	925	475	550	1060	600	1635	300	28	190	1855	160	200	150	998	437
	90.0	280M	925	475	550	1060	600	1635	300	28	190	1915	160	200	150	1013	353
	110.0	315S	930	480	630	1140	680	1705	285	28	175	2140	160	200	150	1368	345
GISO 200-150-500	75.0	280S	1060	550	550	1060	600	1635	300	28	190	1855	160	200	150	1019	458
	90.0	280M	1060	550	550	1060	600	1635	300	28	190	1915	160	200	150	1034	374
	110.0	315S	1060	550	630	1140	680	1706	285	28	175	2140	160	200	150	1389	366
	132.0	315M	1060	550	630	1140	680	1790	325	28	215	2140	160	200	150	1494	383
	160.0	315L	1060	550	630	1140	680	1830	340	28	230	2215	160	200	150	1515	338
GISO 250-200-315	30.0	200L	925	475	550	880	600	1400	260	28	150	1651	180	250	200	755	500
	37.0	225S	925	475	550	880	600	1465	300	28	190	1698	180	250	200	812	496
	45.0	225M	925	475	550	880	600	1465	300	28	190	1723	180	250	200	840	486
	55.0	250M	925	475	550	1050	600	1530	240	28	130	1810	180	250	200	919	495
	75.0	280S	925	475	550	1050	600	1635	300	28	190	1885	180	250	200	1050	489
GISO 250-200-400	75.0	280S	1020	520	550	1050	600	1635	300	28	190	1885	180	250	200	1134	573
	90.0	280M	1020	520	550	1050	600	1635	300	28	190	1935	180	250	200	1150	490
	110.0	315S	1015	515	630	1140	680	1705	285	28	175	2160	180	250	200	1475	452
	132.0	315M	1015	515	630	1140	680	1790	325	28	215	2160	180	250	200	1533	422
	160.0	315L	1015	515	630	1140	680	1820	340	28	230	2235	180	250	200	1722	545
GISO 300-250-400	90.0	280M	1125	565	620	1040	670	1675	320	28	171	1965	220	300	250	1240	580
	110.0	315S	1125	565	620	1140	670	1780	320	28	180	2162	220	300	250	1550	527
	132.0	315M	1125	565	620	1140	670	1780	360	28	220	2277	220	300	250	1550	439
	160.0	315L	1125	565	620	1140	670	1780	360	28	220	2277	220	300	250	1740	563
GISO 300-250-315	55.0	250M	1040	520	620	1040	670	1675	320	28	180	1845	220	300	250	998	574
	75.0	280S	1040	520	620	1040	670	1675	320	28	180	1915	220	300	250	1123	562
	90.0	280M	1040	520	620	1040	670	1675	320	28	180	1955	220	300	250	1138	478
	110.0	315S	1040	520	620	1140	670	1780	320	28	180	2171	220	300	250	1471	448
	132.0	315M	1040	520	620	1140	670	1865	360	28	220	2285	220	300	250	1551	440
	160.0	315L	1040	520	620	1140	670	1865	360	28	220	2285	220	300	250	1641	464

Remarks

1. Standard flange drilling to AS 2129-1982 Table "E"
2. Other drilling options available on request
3. Dimensions subject to change without notice. Do not use for construction purposes.
4. Motor dimensions and data may vary dependent on motor type

ISO End Suction Centrifugal Pump - GISO Pump Dimensions (Pumpset)

Model (960RPM)	Motor (KW)	Motor Size	Measurement													Weight (KG)	
			H1	H2	HC1	HC2	BW	BL	BP	BH	OH	UL	FC	DNS	DND	With Motor	Without Motor
GISO 400-300-460	45.0	280S	1305	685	740	1285	800	1935	315	28	155	2285	300	400	300	1378	866
	55.0	280M	1305	685	740	1330	800	1980	315	28	155	2336	300	400	300	1460	866
	75.0	315S	1305	685	740	1380	800	2030	315	28	155	2495	300	400	300	1450	503
	90.0	315M	1305	685	740	1480	800	2140	315	28	155	2605	300	400	300	1908	874
GISO 400-300-550	45.0	280S	1375	725	740	1275	800	1935	330	28	170	2285	300	400	300	1425	913
	55.0	280M	1375	725	740	1320	800	1980	330	28	170	2336	300	400	300	1506	912
	75.0	315S	1375	725	740	1380	800	2040	330	28	170	2495	300	400	300	1498	551
	90.0	315M	1375	725	740	1480	800	2140	330	28	170	2605	300	400	300	1955	921
	110.0	315L	1375	725	740	1475	800	2135	330	28	170	2605	300	400	300	2141	931
	132.0	355M	1375	725	740	1475	800	2135	330	28	170	2605	300	400	300	2206	913
GISO 400-350-480	45.0	280S	1435	755	840	1275	900	1965	345	28	160	2285	300	400	350	1528	1016
	55.0	280M	1435	755	840	1310	900	2000	345	28	160	2336	300	400	350	1609	1015
	75.0	315S	1435	755	840	1380	900	2070	345	28	160	2495	300	400	350	1609	662
	90.0	315M	1435	755	840	1480	900	2170	345	28	160	2605	300	400	350	2050	1016
	110.0	315L	1435	755	840	1475	900	2165	345	28	160	2605	300	400	350	2241	1031
	132.0	355M	1435	755	840	1475	900	2165	345	28	160	2605	300	400	350	2306	1013
GISO 400-400-410	45.0	280S	1335	685	740	1285	800	1985	335	28	135	2285	300	400	400	1452	940
	55.0	280M	1335	685	740	1330	800	2030	335	28	135	2336	300	400	400	1540	946
	75.0	315S	1335	685	740	1380	800	2080	335	28	135	2495	300	400	400	1540	593
	90.0	315M	1335	685	740	1480	800	2180	335	28	135	2605	300	400	400	1990	956

Remarks

1. Standard flange drilling to AS 2129-1982 Table "E"
2. Other drilling options available on request
3. Dimensions subject to change without notice. Do not use for construction purposes.
4. Motor dimensions and data may vary dependent on motor type

ISO End Suction Centrifugal Pump - GISO Pump Grease-Lubricated Sectional Drawing

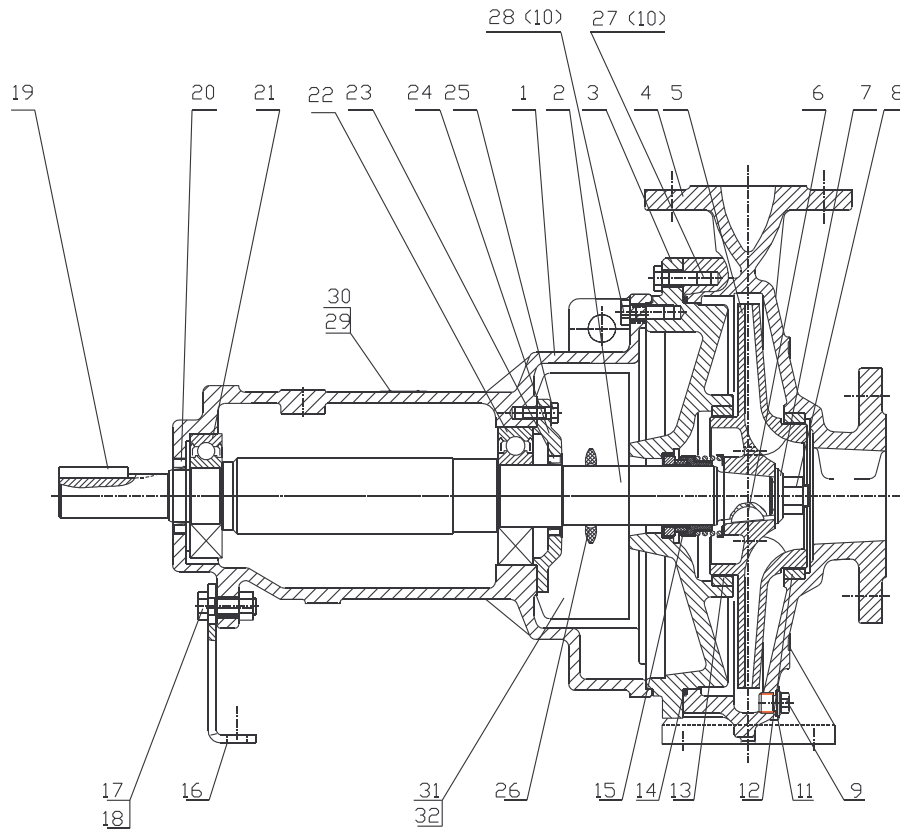

Item	Description	Item	Description
1	Bearing Box	17	Connection Bolt - Supporting Leg & Bearing Box
2	Shaft	18	Connection Nut - Supporting Leg & Bearing Box
3	Rear Cover Plate	19	Connection Key
4	Pump Casing	20	Oil Seal - Drive End
5	Impeller	21	Bearing - Drive End
6	Impeller Connection Key	22	Bearing - Impeller End
7	Impeller Washer	23	Oil Seal - Impeller End
8	Impeller Locking Nut	24	Bearing Gland
9	Venting Plug	25	Connection Bolt - Bearing Gland & Bearing Box
10	Connection Bolt - Bearing Box & Pump Casing	26	Water Proof Ring
11	Washer	27	Connection Bolt - Rear Cover Plate & Pump Casing
12	Front Friction Ring	28	Connection Bolt - Bearing Box & Rear Cover Plate
13	Rear Friction Ring	29	Rivet
14	O Ring - Pump Casing	30	Nameplate
15	Mechanical Seal	31	Protective Sleeve
16	Supporting Leg	32	Connection Bolt - Protective Sleeve

ISO End Suction Centrifugal Pump - GISO Pump Component Interchangeability Module #1

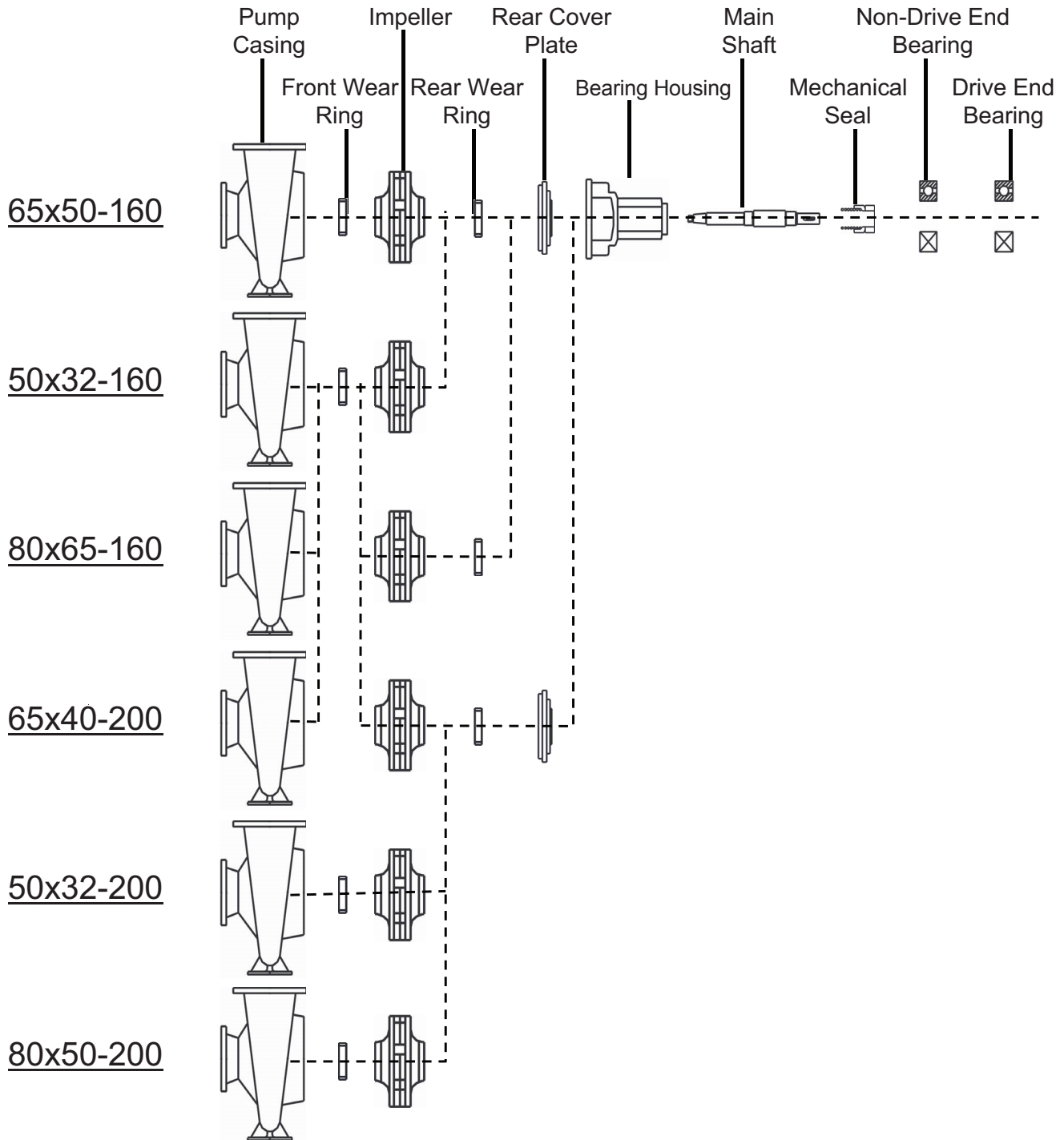

ISO End Suction Centrifugal Pump - GISO Pump Component Interchangeability Module #2

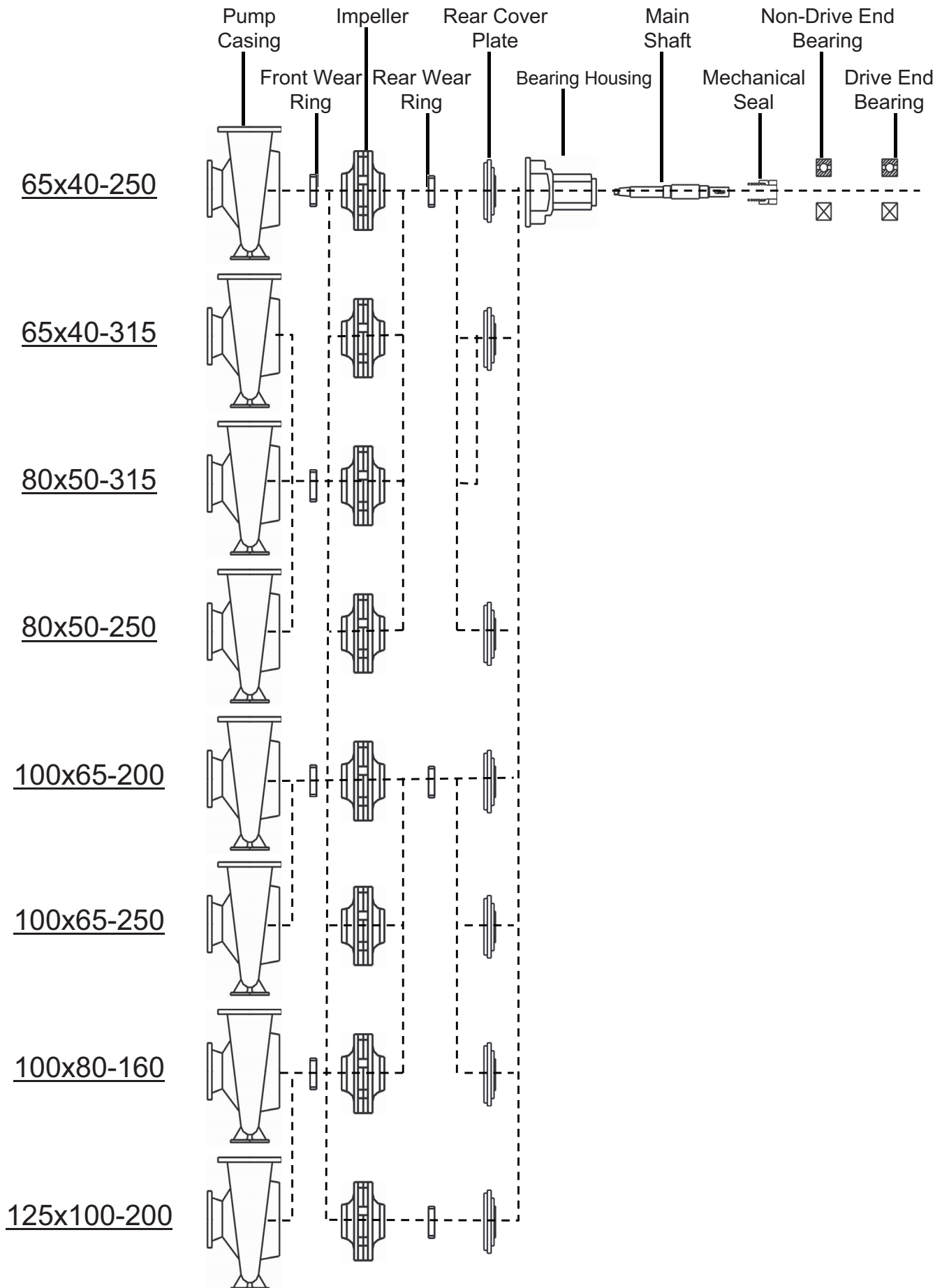

ISO End Suction Centrifugal Pump - GISO Pump Component Interchangeability Module #3

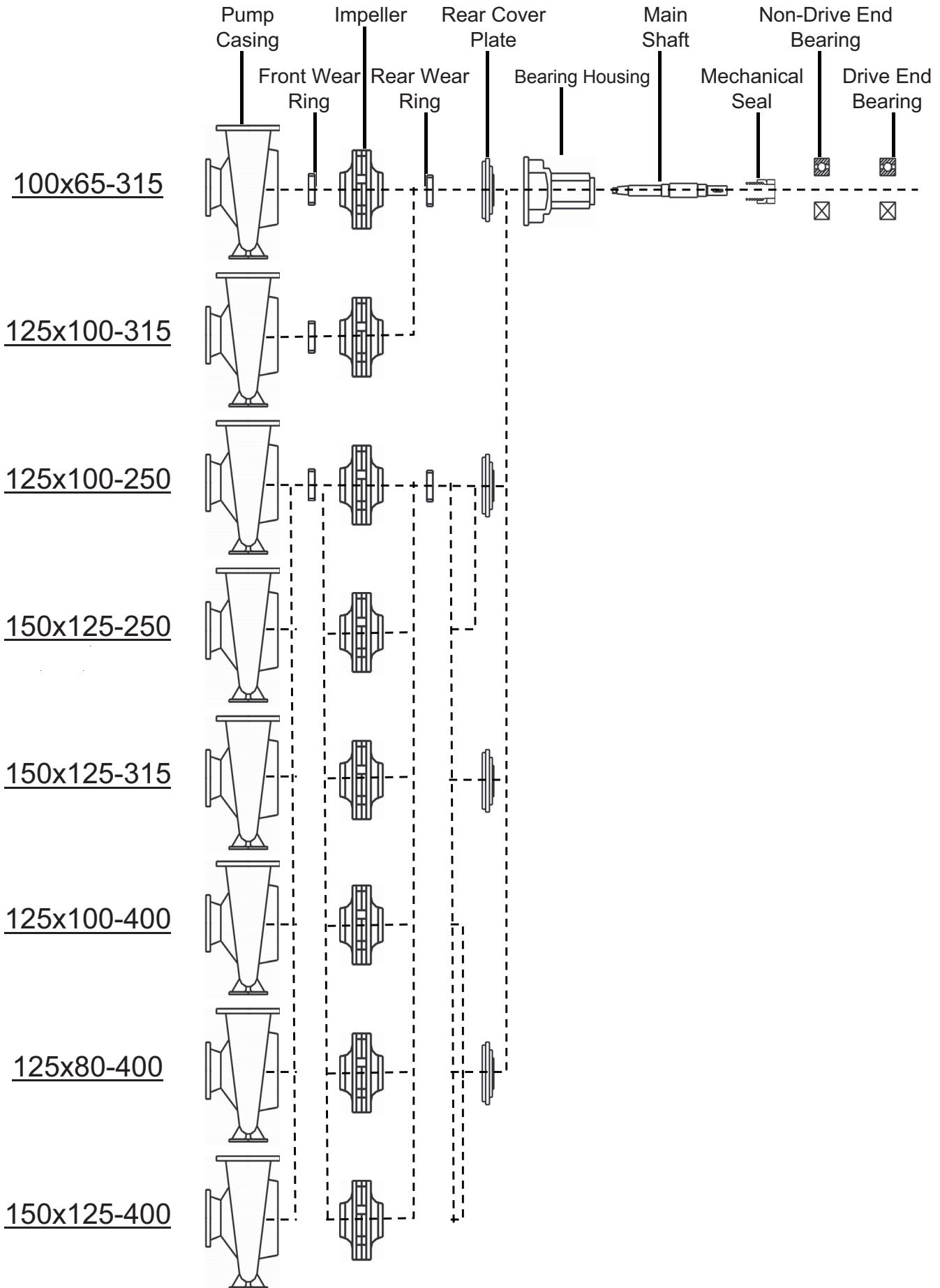

ISO End Suction Centrifugal Pump - GISO Pump Component Interchangeability Module #4

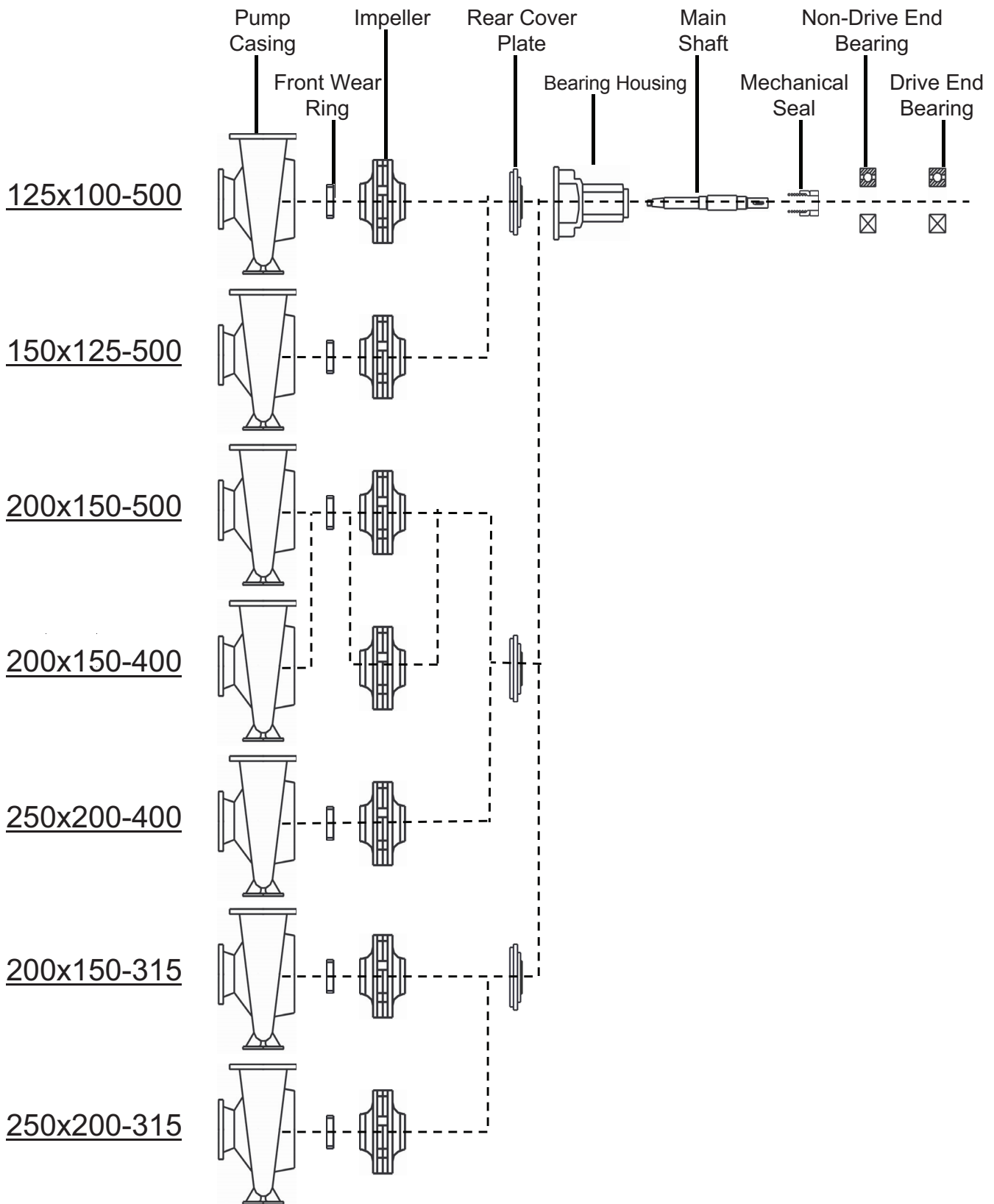

ISO End Suction Centrifugal Pump - GISO Pump Component Interchangeability Module #5

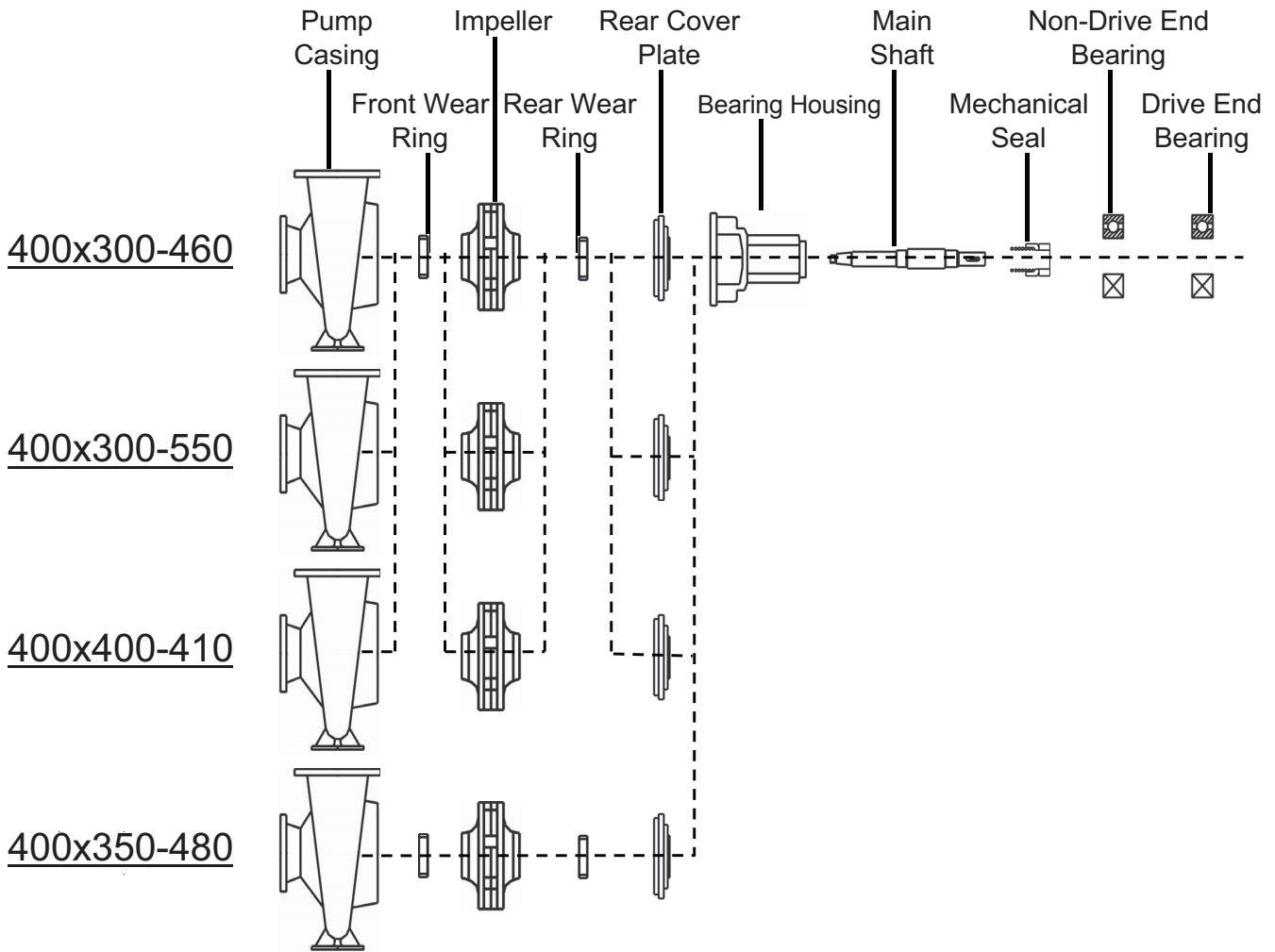

ISO End Suction Centrifugal Pump - GIS Pump Dimensions (Pumpset - 2 Pole)

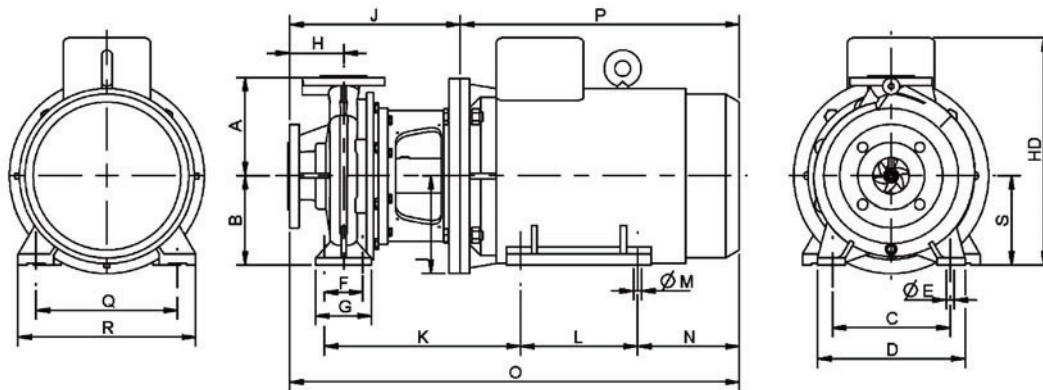

Model (2900RPM)	Measurement								Motor (KW)	Motor Size	Measurement										Weight (KG)			
	A	B	C	D	E	F	G	H			I	J	K	L	N	M	O	P	Q	R	S	HD	With Motor	Without Motor
GIS 50-32-160	160	132	190	240	14	70	100	80	3.0	100L	125	227	245	140	106	12	536	309	160	205	100	269	81	45
	160	132	190	240	14	70	100	80	4.0	112M	125	227	252	140	128	12	565	338	190	205	112	302	94	50
	160	132	190	240	14	70	100	80	5.5	132S	150	256	300	140	153	12	638	382	216	270	132	342	119	54
GIS 50-32-200	180	160	190	240	14	70	100	80	5.5	132S	150	256	300	140	153	12	638	382	216	270	132	342	138	73
	180	160	190	240	14	70	100	80	7.5	132S	150	256	300	140	153	12	638	382	216	270	132	342	144	76
	180	160	190	240	14	70	100	80	11.0	160M	175	290	353	210	183	15	791	501	254	320	160	408	206	88
GIS 65-50-160	160	132	190	240	14	70	100	80	4.0	112M	125	227	252	140	128	12	565	338	190	205	112	302	105	61
	160	132	190	240	14	70	100	80	5.5	132S	150	256	300	140	153	12	638	382	216	270	132	342	130	65
	160	132	190	240	14	70	100	80	7.5	132S	150	256	300	140	153	12	638	382	216	270	132	342	136	68
GIS 65-40-200	180	160	212	265	14	70	100	100	7.5	132S	150	276	300	140	153	12	658	382	216	270	132	342	144	76
	180	160	212	265	14	70	100	100	11.0	160M	175	310	353	210	183	15	811	501	254	320	160	408	206	88
	180	160	212	265	14	70	100	100	15.0	160M	175	310	353	210	183	15	811	501	254	320	160	408	215	86
GIS 80-65-160	180	160	212	265	14	70	100	100	5.5	132S	150	276	300	140	153	12	658	382	216	270	132	342	137	72
	180	160	212	265	14	70	100	100	7.5	132S	150	276	300	140	153	12	658	382	216	270	132	342	143	75
	180	160	212	265	14	70	100	100	11.0	160M	175	310	353	210	183	15	811	501	254	320	160	408	205	87
	180	160	212	265	14	70	100	100	15.0	160M	175	310	353	210	183	15	811	501	254	320	160	408	213	84
GIS 80-50-200	200	160	212	265	14	70	100	100	11.0	160M	175	310	353	210	183	15	811	501	254	320	160	408	210	92
	200	160	212	265	14	70	100	100	15.0	160M	175	310	353	210	183	15	811	501	254	320	160	408	218	89
	200	160	212	265	14	70	100	100	18.5	160L	175	310	353	254	183	15	855	545	254	320	160	408	242	95
	200	160	212	265	14	70	100	100	22.0	180M	175	310	366	241	218	15	890	580	279	355	180	448	283	97
GIS 65-40-250	225	180	250	320	14	95	125	100	11.0	160M	175	310	365	210	183	15	811	501	254	320	160	408	239	121
	225	180	250	320	14	95	125	100	15.0	160M	175	310	365	210	183	15	811	501	254	320	160	408	247	118
	225	180	250	320	14	95	125	100	18.5	160L	175	310	365	254	183	15	855	545	254	320	160	408	274	127
	225	180	250	320	14	95	125	100	22.0	180M	175	310	378	241	218	15	890	580	279	355	180	448	300	114
	225	180	250	320	14	95	125	100	30.0	200L	200	318	398	305	234	19	990	672	318	395	200	504	385	143
GIS 65-40-315	250	200	280	345	14	95	125	125	22.0	180M	175	335	378	241	218	15	915	580	279	355	180	448	326	140
	250	200	280	345	14	95	125	125	30.0	200L	200	343	398	305	234	19	1015	672	318	395	200	504	397	155
	250	200	280	345	14	95	125	125	37.0	200L	200	343	398	305	234	19	1015	672	318	395	200	504	412	149
	250	200	280	345	14	95	125	125	45.0	225M	225	343	414	311	249	19	1052	709	356	435	225	553	475	148

Remarks

1. Standard flange drilling to AS 2129-1982 Table "E"
2. Other drilling options available on request
3. Dimensions subject to change without notice. Do not use for construction purposes.
4. Motor dimensions and data may vary dependent on motor type

ISO End Suction Centrifugal Pump - GIS Pump Dimensions (Pumpset - 2 Pole)

Model (2900RPM)	Measurement								Motor (KW)	Motor Size	Measurement											Weight (KG)		
	A	B	C	D	E	F	G	H			I	J	K	L	N	M	O	P	Q	R	S	HD	With Motor	Without Motor
GIS 80-50-250	225	180	250	320	14	95	125	125	18.5	160L	175	335	365	254	183	15	880	545	254	320	160	408	278	131
	225	180	250	320	14	95	125	125	22.0	180M	175	335	378	241	218	15	915	580	279	355	180	448	305	119
	225	180	250	320	14	95	125	125	30.0	200L	200	343	398	305	234	19	1015	672	318	395	200	504	390	148
	225	180	250	320	14	95	125	125	37.0	200L	200	343	398	305	234	19	1015	672	318	395	200	504	406	143
	225	180	250	320	14	95	125	125	45.0	225M	225	343	414	311	249	19	1052	709	356	435	225	553	472	145
GIS 80-50-315	280	225	280	345	14	95	125	125	30.0	200L	200	343	398	305	234	19	1015	672	318	395	200	504	410	168
	280	225	280	345	14	95	125	125	37.0	200L	200	343	398	305	234	19	1015	672	318	395	200	504	426	163
	280	225	280	345	14	95	125	125	45.0	225M	225	343	414	311	249	19	1052	709	356	435	225	553	489	162
	280	225	280	345	14	95	125	125	55.0	250M	275	380	470	349	274	24	1171	791	406	490	250	609	602	184
	280	225	280	345	14	95	125	125	75.0	280S	275	380	492	368	284	24	1221	842	457	550	280	668	759	198
GIS 100-80-160	200	160	212	280	14	95	125	100	11.0	160M	175	310	365	210	183	15	811	501	254	320	160	408	225	107
	200	160	212	280	14	95	125	100	15.0	160M	175	310	365	210	183	15	811	501	254	320	160	408	233	104
	200	160	212	280	14	95	125	100	18.5	160L	175	310	365	254	183	15	855	545	254	320	160	408	258	111
	200	160	212	280	14	95	125	100	22.0	180M	175	310	378	241	218	15	890	580	279	355	180	448	302	116
GIS 100-65-200	225	180	250	320	14	95	125	100	15.0	160M	175	310	365	210	183	15	811	501	254	320	160	408	247	118
	225	180	250	320	14	95	125	100	18.5	160L	175	310	365	254	183	15	855	545	254	320	160	408	273	126
	225	180	250	320	14	95	125	100	22.0	180M	175	310	378	241	218	15	890	580	279	355	180	448	300	114
	225	180	250	320	14	95	125	100	30.0	200L	200	318	398	305	234	19	990	672	318	395	200	504	385	143
	225	180	250	320	14	95	125	100	37.0	200L	200	318	398	305	234	19	990	672	318	395	200	504	401	138
GIS 100-65-250	250	200	280	360	18	120	160	125	30.0	200L	200	343	411	305	234	19	1015	672	318	395	200	504	394	152
	250	200	280	360	18	120	160	125	37.0	200L	200	343	411	305	234	19	1015	672	318	395	200	504	410	147
	250	200	280	360	18	120	160	125	45.0	225M	225	343	427	311	249	19	1052	709	356	435	225	553	482	155
	250	200	280	360	18	120	160	125	55.0	250M	275	380	483	349	274	24	1171	791	406	490	250	609	593	175
	250	200	280	360	18	120	160	125	75.0	280S	275	380	505	368	284	24	1221	842	457	550	280	668	750	189
GIS 125-100-200	280	200	280	360	18	120	160	125	22.0	180M	175	335	391	241	218	15	915	580	279	355	180	448	327	141
	280	200	280	360	18	120	160	125	30.0	200L	200	343	411	305	234	19	1015	672	318	395	200	504	399	157
	280	200	280	360	18	120	160	125	37.0	200L	200	343	411	305	234	19	1015	672	318	395	200	504	415	152
	280	200	280	360	18	120	160	125	45.0	225M	225	343	427	311	249	19	1052	709	356	435	225	553	487	160
	280	200	280	360	18	120	160	125	55.0	250M	275	380	483	349	274	24	1171	791	406	490	250	609	597	179
	280	200	280	360	18	120	160	125	75.0	280S	275	380	505	368	284	24	1221	842	457	550	280	668	754	193
GIS 100-65-315	280	225	315	400	18	120	160	125	55.0	250M	275	387	490	349	274	24	1178	791	406	490	250	609	642	224
	280	225	315	400	18	120	160	125	75.0	280S	275	387	512	368	284	24	1229	842	457	550	280	668	798	237
	280	225	315	400	18	120	160	125	90.0	280M	275	387	512	419	284	24	1280	893	457	550	280	668	883	289
GIS 125-100-250	280	225	315	400	18	120	160	140	55.0	250M	275	402	490	349	274	24	1193	791	406	490	250	609	656	238
	280	225	315	400	18	120	160	140	75.0	280S	275	402	512	368	284	24	1244	842	457	550	280	668	812	251
	280	225	315	400	18	120	160	140	90.0	280M	275	402	512	419	284	24	1295	893	457	550	280	668	897	303
	280	225	315	400	18	120	160	140	110.0	315S	330	402	538	406	423	28	1447	1045	508	635	315	875	1319	307
GIS 125-100-315	315	250	315	400	18	120	160	140	90.0	280M	275	402	512	419	284	24	1295	893	457	550	280	668	910	316
	315	250	315	400	18	120	160	140	110.0	315S	330	402	538	406	423	28	1447	1045	508	635	315	875	1334	322

Remarks

1. Standard flange drilling to AS 2129-1982 Table "E"
2. Other drilling options available on request
3. Dimensions subject to change without notice. Do not use for construction purposes.
4. Motor dimensions and data may vary dependent on motor type

ISO End Suction Centrifugal Pump - GIS Pump Dimensions (Pumpset - 4 Pole)

Model (1450RPM)	Measurement								Motor (KW)	Motor Size	Measurement											Weight (KG)		
	A	B	C	D	E	F	G	H			I	J	K	L	N	M	O	P	Q	R	S	HD	With Motor	Without Motor
GIS 50-32-160	160	132	190	240	14	70	100	80	0.75	80M	100	215	220	100	165	94	459	244	125	165	80	225	62	44
GIS 50-32-200	180	160	190	240	14	70	100	80	0.75	80M	100	215	220	100	165	94	459	244	125	165	80	225	78	60
	180	160	190	240	14	70	100	80	1.1	90S	100	215	226	100	165	113	484	269	140	180	90	245	83	59
	180	160	190	240	14	70	100	80	2.2	100L	125	227	245	140	215	106	536	309	160	205	100	269	100	63
GIS 65-50-160	160	132	190	240	14	70	100	80	0.75	80M	100	215	220	100	165	94	459	244	125	165	80	225	73	55
	160	132	190	240	14	70	100	80	1.1	90S	100	215	226	100	165	113	484	269	140	180	90	245	75	51
GIS 65-40-200	180	160	212	265	14	70	100	100	1.1	90S	100	235	226	100	165	113	504	269	140	180	90	245	84	60
	180	160	212	265	14	70	100	100	1.5	90L	100	235	226	125	165	113	529	294	140	180	90	245	90	60
	180	160	212	265	14	70	100	100	2.2	100L	125	247	245	140	215	106	556	309	160	205	100	269	101	64
GIS 80-65-160	180	160	212	265	14	70	100	100	1.1	90S	100	235	226	100	165	113	504	269	140	180	90	245	83	59
	180	160	212	265	14	70	100	100	1.5	90L	100	235	226	125	165	113	529	294	140	180	90	245	88	58
GIS 80-50-200	200	160	212	265	14	70	100	100	1.5	90L	100	235	226	125	165	113	529	294	140	180	90	245	93	63
	200	160	212	265	14	70	100	100	2.2	100L	125	247	245	140	215	106	556	309	160	205	100	269	105	68
	200	160	212	265	14	70	100	100	3.0	100L	125	247	245	140	215	106	556	309	160	205	100	269	109	70
GIS 65-40-250	225	180	250	320	14	95	125	100	1.1	90S	100	234	237	100	165	113	503	269	140	180	90	245	104	80
	225	180	250	320	14	95	125	100	1.5	90L	100	234	237	125	165	113	528	294	140	180	90	245	111	81
	225	180	250	320	14	95	125	100	2.2	100L	125	244	254	140	215	106	553	309	160	205	100	269	123	86
	225	180	250	320	14	95	125	100	3.0	100L	125	244	254	140	215	106	553	309	160	205	100	269	127	88
	225	180	250	320	14	95	125	100	4.0	112M	125	244	261	140	215	128	582	338	190	230	112	302	136	88
GIS 65-40-315	250	200	280	345	14	95	125	125	2.2	100L	125	269	254	140	215	106	578	309	160	205	100	269	142	105
	250	200	280	345	14	95	125	125	3.0	100L	125	269	254	140	215	106	578	309	160	205	100	269	146	107
	250	200	280	345	14	95	125	125	4.0	112M	125	269	261	140	215	128	607	338	190	230	112	302	153	105
	250	200	280	345	14	95	125	125	5.5	132S	150	298	309	140	265	153	680	382	216	270	132	342	189	122
	250	200	280	345	14	95	125	125	7.5	132M	150	298	309	178	265	153	718	420	216	270	132	342	207	127
GIS 80-50-250	225	180	250	320	14	95	125	125	3.0	100L	125	269	254	140	215	106	578	309	160	205	100	269	132	93
	225	180	250	320	14	95	125	125	4.0	112M	125	269	261	140	215	128	607	338	190	230	112	302	141	93
	225	180	250	320	14	95	125	125	5.5	132S	150	298	309	140	265	153	680	382	216	270	132	342	176	109
GIS 80-50-315	280	225	280	345	14	95	125	125	4.0	112M	125	269	261	140	215	128	607	338	190	230	112	302	163	115
	280	225	280	345	14	95	125	125	5.5	132S	150	298	309	140	265	153	680	382	216	270	132	342	204	137
	280	225	280	345	14	95	125	125	7.5	132M	150	298	309	178	265	153	718	420	216	270	132	342	221	141
	280	225	280	345	14	95	125	125	11.0	160M	175	335	365	210	300	183	836	501	254	320	160	408	271	147
GIS 100-80-160	200	160	212	280	14	95	125	100	1.1	90S	100	234	237	100	165	113	503	269	140	180	90	245	98	74
	200	160	212	280	14	95	125	100	1.5	90L	100	234	237	125	165	113	528	294	140	180	90	245	104	74
	200	160	212	280	14	95	125	100	2.2	100L	125	244	254	140	215	106	553	309	160	205	100	269	119	82
	200	160	212	280	14	95	125	100	3.0	100L	125	244	254	140	215	106	553	309	160	205	100	269	123	84
	200	160	212	280	14	95	125	100	4.0	112M	125	244	261	140	215	128	582	338	190	230	112	302	128	80
GIS 100-65-200	225	180	250	320	14	95	125	100	2.2	100L	125	244	254	140	215	106	553	309	160	205	100	269	122	85
	225	180	250	320	14	95	125	100	3.0	100L	125	244	254	140	215	106	553	309	160	205	100	269	127	88
	225	180	250	320	14	95	125	100	4.0	112M	125	244	261	140	215	128	582	338	190	230	112	302	136	88
	225	180	250	320	14	95	125	100	5.5	132S	150	273	309	140	265	153	655	382	216	270	132	342	171	104

Remarks

1. Standard flange drilling to AS 2129-1982 Table "E"
2. Other drilling options available on request
3. Dimensions subject to change without notice. Do not use for construction purposes.
4. Motor dimensions and data may vary dependent on motor type

ISO End Suction Centrifugal Pump - GIS Pump Dimensions (Pumpset - 4 Pole)

Model (1450RPM)	Measurement								Motor (KW)	Motor Size	Measurement											Weight (KG)		
	A	B	C	D	E	F	G	H			I	J	K	L	N	M	O	P	Q	R	S	HD	With Motor	Without Motor
GIS 100-65-250	250	200	280	360	18	120	160	125	3.0	100L	125	269	267	140	215	106	578	309	160	205	100	269	142	103
	250	200	280	360	18	120	160	125	4.0	112M	125	269	274	140	215	128	607	338	190	230	112	302	150	102
	250	200	280	360	18	120	160	125	5.5	132S	150	298	322	140	265	153	680	382	216	270	132	342	187	120
	250	200	280	360	18	120	160	125	7.5	132M	150	298	322	178	265	153	718	420	216	270	132	342	204	124
GIS 125-100-200	280	200	280	360	18	120	160	125	3.0	100L	125	269	267	140	215	106	578	309	160	205	100	269	147	108
	280	200	280	360	18	120	160	125	4.0	112M	125	269	274	140	215	128	607	338	190	230	112	302	155	107
	280	200	280	360	18	120	160	125	5.5	132S	150	298	322	140	265	153	680	382	216	270	132	342	192	125
	280	200	280	360	18	120	160	125	7.5	132M	150	298	322	178	265	153	718	420	216	270	132	342	208	128
GIS 100-65-315	280	225	315	400	18	120	160	125	5.5	132S	150	305	329	140	265	153	687	382	216	270	132	342	217	150
	280	225	315	400	18	120	160	125	7.5	132M	150	305	329	178	265	153	725	420	216	270	132	342	236	156
	280	225	315	400	18	120	160	125	11.0	160M	175	341	384	210	300	183	842	501	254	320	160	408	284	160
	280	225	315	400	18	120	160	125	15.0	160L	175	341	384	254	300	183	886	545	254	320	160	408	309	163
GIS 125-100-250	280	225	315	400	18	120	160	140	11.0	160M	175	356	384	210	300	183	857	501	254	320	160	408	298	174
	280	225	315	400	18	120	160	140	15.0	160L	175	356	384	254	300	183	901	545	254	320	160	408	323	177
	280	225	315	400	18	120	160	140	18.5	180M	175	356	397	241	300	218	936	580	279	355	180	448	360	176
	280	225	315	400	18	120	160	140	22.0	180L	175	356	397	279	300	218	974	618	279	355	180	448	372	173
	280	225	315	400	18	120	160	140	30.0	200L	200	365	418	305	350	234	1037	672	318	395	200	504	467	212
GIS 125-100-315	315	250	315	400	18	120	160	140	11.0	160M	175	356	384	210	300	183	857	501	254	320	160	408	320	196
	315	250	315	400	18	120	160	140	15.0	160L	175	356	384	254	300	183	901	545	254	320	160	408	346	200
	315	250	315	400	18	120	160	140	18.5	180M	175	356	397	241	300	218	936	580	279	355	180	448	383	199
	315	250	315	400	18	120	160	140	22.0	180L	175	356	397	279	300	218	974	618	279	355	180	448	395	196
	315	250	315	400	18	120	160	140	30.0	200L	200	365	418	305	350	234	1037	672	318	395	200	504	495	240
GIS 125-80-400	355	280	355	435	18	120	160	125	11.0	160M	175	341	384	210	300	183	842	501	254	320	160	408	344	220
	355	280	355	435	18	120	160	125	15.0	160L	175	341	384	254	300	183	886	545	254	320	160	408	370	224
	355	280	355	435	18	120	160	125	18.5	180M	175	341	397	241	300	218	921	580	279	355	180	448	408	224
	355	280	355	435	18	120	160	125	22.0	180L	175	341	397	279	300	218	959	618	279	355	180	448	420	221
	355	280	355	435	18	120	160	125	30.0	200L	200	350	418	305	350	234	1022	672	318	395	200	504	529	274
GIS 125-100-400	355	280	400	500	22	150	200	140	18.5	180M	175	356	412	241	300	218	936	580	279	355	180	448	445	261
	355	280	400	500	22	150	200	140	22.0	180L	175	356	412	279	300	218	974	618	279	355	180	448	457	258
	355	280	400	500	22	150	200	140	30.0	200L	200	365	433	305	350	234	1037	672	318	395	200	504	547	292
	355	280	400	500	22	150	200	140	37.0	225S	225	400	484	286	400	249	1084	684	356	435	225	553	580	264
	355	280	400	500	22	150	200	140	45.0	225M	225	400	484	311	400	249	1109	709	356	435	225	553	620	266
GIS 150-125-250	355	250	315	400	18	120	160	140	11.0	160M	175	356	384	210	300	183	857	501	254	320	160	408	316	192
	355	250	315	400	18	120	160	140	15.0	160L	175	356	384	254	300	183	901	545	254	320	160	408	342	196
	355	250	315	400	18	120	160	140	18.5	180M	175	356	397	241	300	218	936	580	279	355	180	448	379	195
	355	250	315	400	18	120	160	140	22.0	180L	175	356	397	279	300	218	974	618	279	355	180	448	391	192
	355	250	315	400	18	120	160	140	30.0	200L	200	365	418	305	350	234	1037	672	318	395	200	504	491	236
GIS 150-125-315	355	280	400	500	22	150	200	140	18.5	180M	175	356	412	241	300	218	936	580	279	355	180	448	417	233
	355	280	400	500	22	150	200	140	22.0	180L	175	356	412	279	300	218	974	618	279	355	180	448	430	231
	355	280	400	500	22	150	200	140	30.0	200L	200	365	433	305	350	234	1037	672	318	395	200	504	520	265
	355	280	400	500	22	150	200	140	37.0	225S	225	400	484	286	400	249	1084	684	356	435	225	553	549	233
	355	280	400	500	22	150	200	140	45.0	225M	225	400	484	311	400	249	1109	709	356	435	225	553	593	239
GIS 150-125-400	400	315	400	500	22	150	200	140	30.0	200L	200	365	433	305	350	234	1037	672	318	395	200	504	561	306
	400	315	400	500	22	150	200	140	37.0	225S	225	400	484	286	400	249	1084	684	356	435	225	553	599	283
	400	315	400	500	22	150	200	140	45.0	225M	225	400	484	311	400	249	1109	709	356	435	225	553	640	286

Remarks

1. Standard flange drilling to AS 2129-1982 Table "E"
2. Other drilling options available on request
3. Dimensions subject to change without notice. Do not use for construction purposes.
4. Motor dimensions and data may vary dependent on motor type

ISO End Suction Centrifugal Pump - GIS Pump Sectional Drawing (Pumpset)

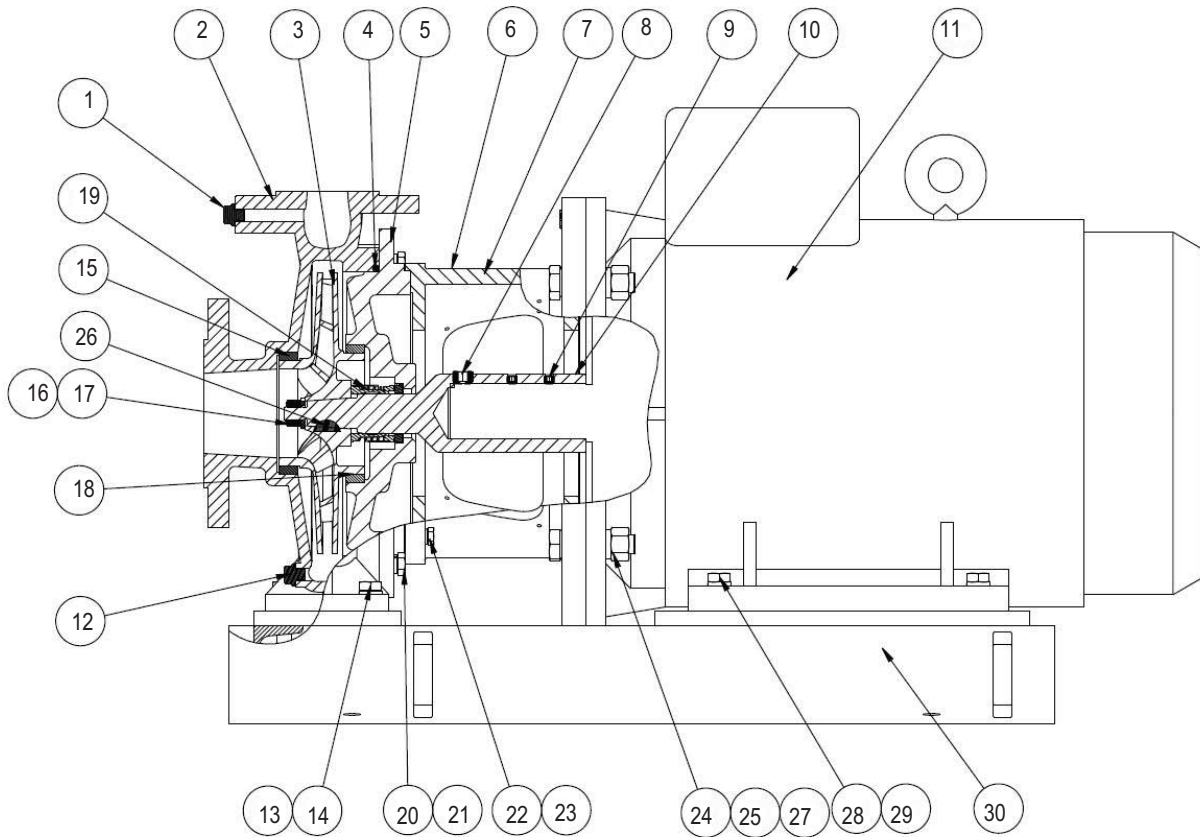

Item	Description	Item	Description
1	Plug-on Flange	16	Impeller Nut
2	Casing	17	Impeller Gasket
3	Impeller	18	Wearing Ring-Motor End
4	O-Ring	19	Mechanical Seal
5	Cover	20	Bolt-On Casing and Cover
6	Nameplate	21	Spring Ring-On Casing and Cover
7	Adaptor	22	Bolt-On Adaptor Impeller End
8	Plug-on Shaft	23	Spring Ring-On Adaptor Impeller End
9	Plug-on Shaft	24	Bolt-On Adaptor Motor End
10	Stub Shaft	25	Spring Ring-On Adaptor Motor End
11	Motor	26	Impeller Key
12	Drain Plug-On Casing	27	Nut-On Adaptor Motor End
13	Bolt-On Baseplate Pump Side	28	Bolt-On Baseplate Motor End
14	Spring Ring-On Baseplate Pump Side	29	Spring Ring-On Baseplate Motor End
15	Wearing Ring-Suction End	30	Baseplate

ISO End Suction Centrifugal Pump - GIS Pump Component Interchangeability Module #1

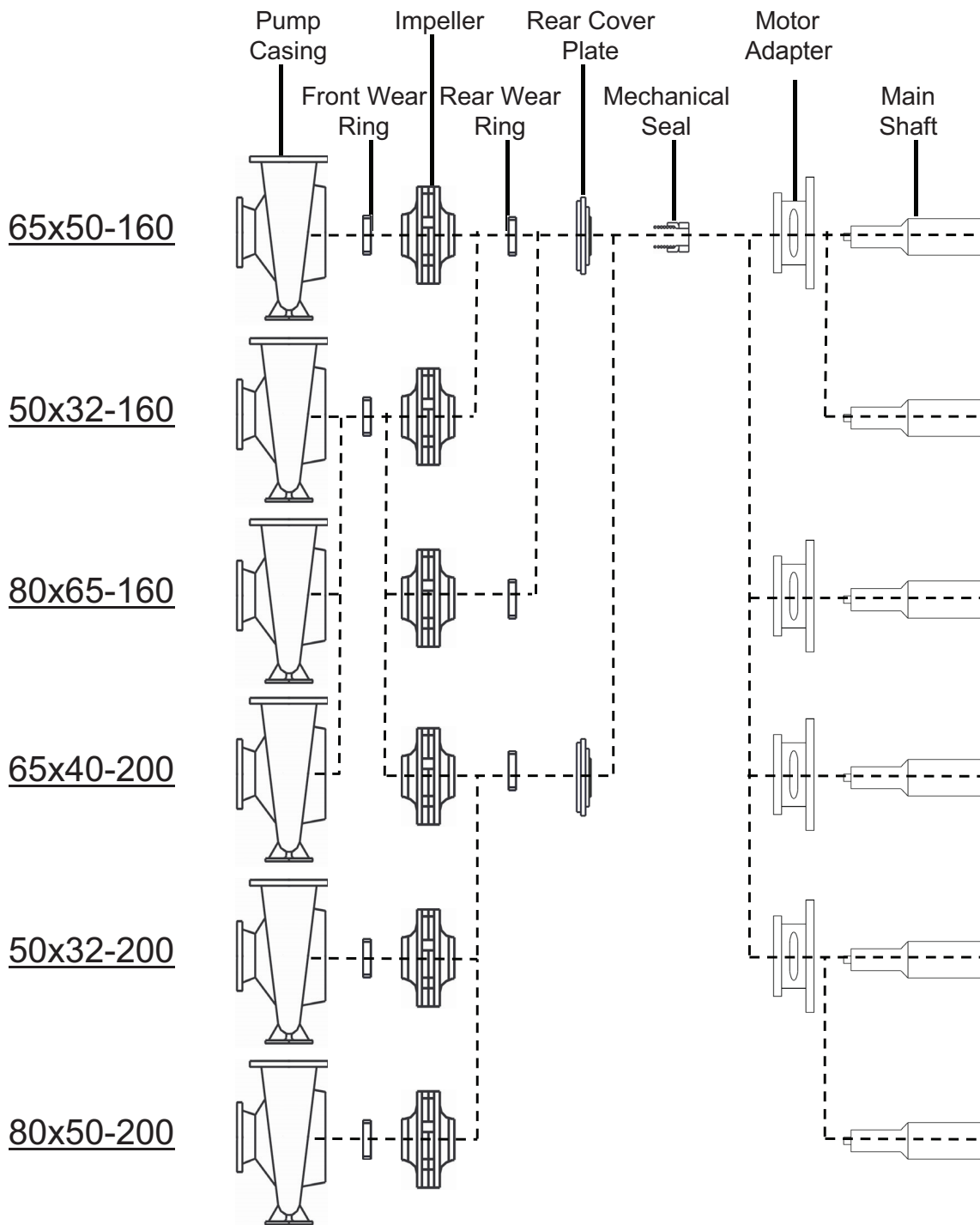

ISO End Suction Centrifugal Pump - GIS Pump Component Interchangeability Module #2

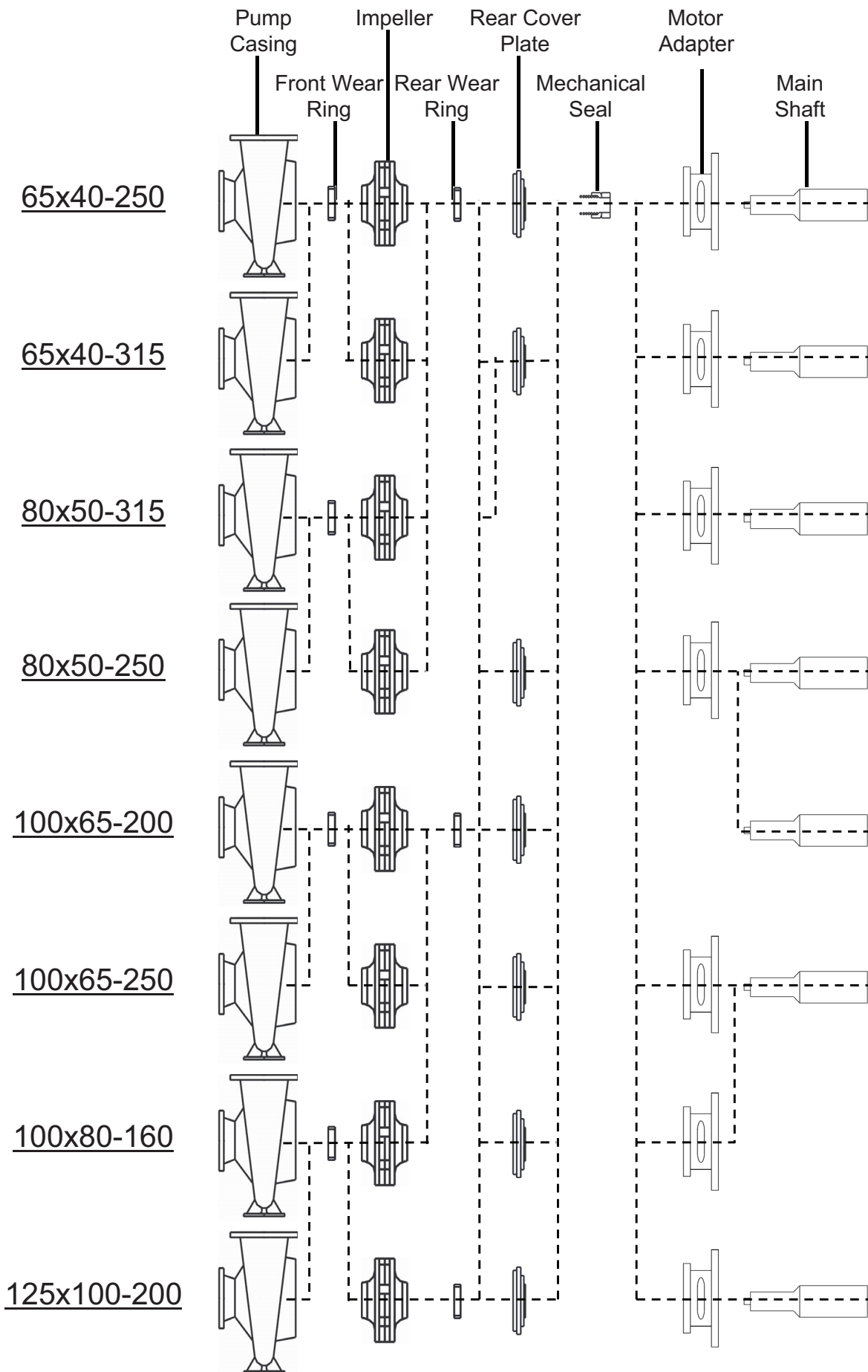

ISO End Suction Centrifugal Pump - GIS Pump Component Interchangeability Module #3

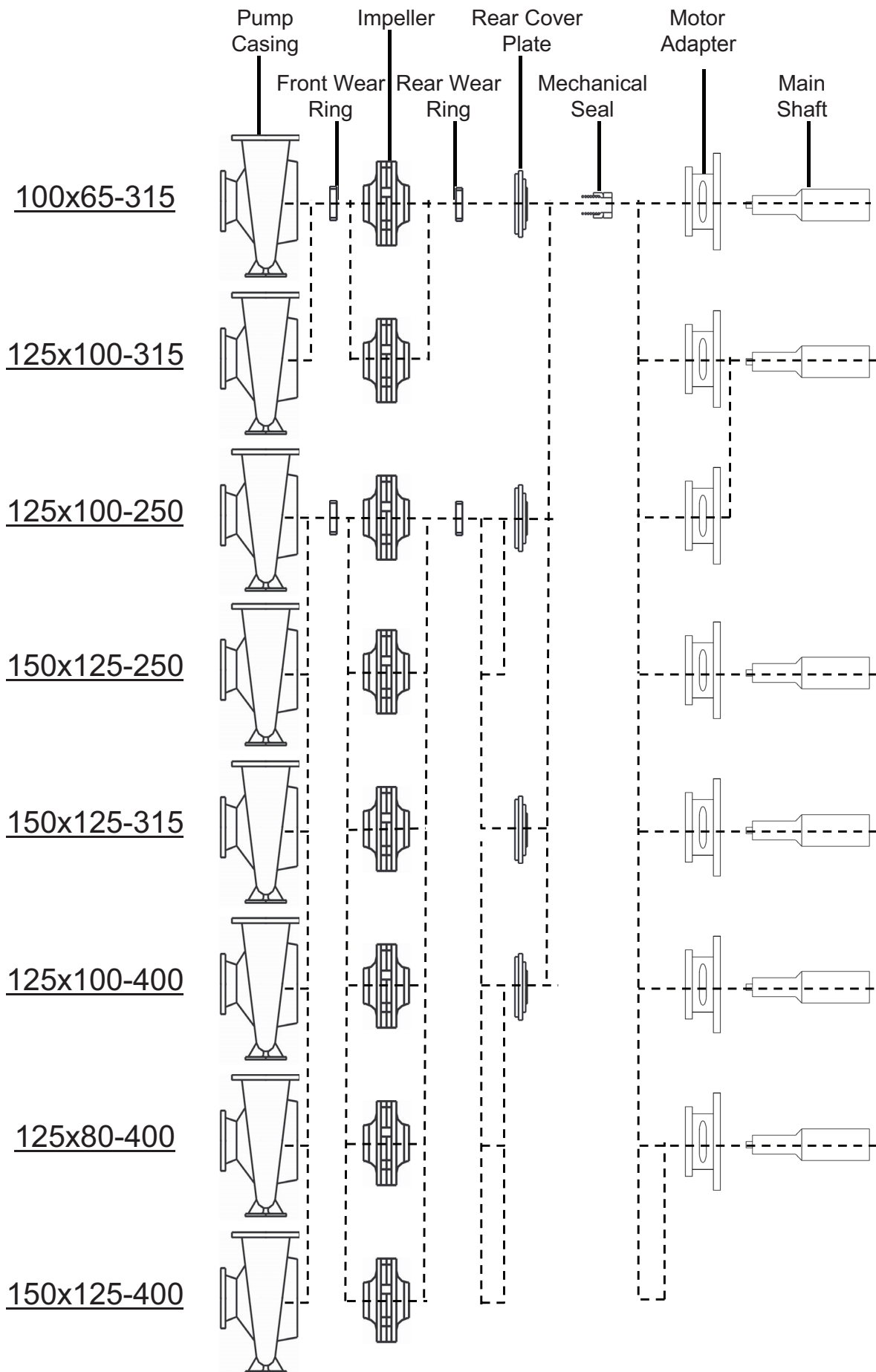

ISO End Suction Centrifugal Pump - GISO (Long Coupled) Pump Material Configuration

Standard Material

Pump Casing	Pump Cover	Motor Adapter	Impeller	Shaft	Wear Ring	Impeller Key	Impeller Nut
EN-GJL-250	EN-GJL-250	-	EN 1.4301 / AISI 304	EN 1.4021 / AISI 420	EN 1.4301 / AISI 304	EN 1.4021 / AISI 420	EN 1.4301 / AISI 304

Optional Material

Pump Casing	Pump Cover	Motor Adapter	Impeller	Shaft	Wear Ring	Impeller Key	Impeller Nut
EN-GJL-250	EN-GJL-250	-	CuSn10	EN 1.4021 / AISI 420	CuSn10	EN 1.4021 / AISI 420	EN 1.4301 / AISI 304
EN-GJL-250	EN-GJL-250	-	EN-GJL-250	EN 1.4021 / AISI 420	EN 1.4301 / AISI 304	EN 1.4021 / AISI 420	EN 1.4301 / AISI 304
EN-GJL-250	EN-GJL-250	-	CuSn10	EN 1.4021 / AISI 420	CuSn10	EN 1.4021 / AISI 420	EN 1.4301 / AISI 304
EN 1.4301 / AISI 304	EN 1.4301 / AISI 304	-	EN 1.4301 / AISI 304	EN 1.4301 / AISI 304	EN 1.4301 / AISI 304	EN 1.4301 / AISI 304	EN 1.4301 / AISI 304
EN 1.4401 / AISI 316	EN 1.4401 / AISI 316	-	EN 1.4401 / AISI 316	EN 1.4401 / AISI 316	EN 1.4401 / AISI 316	EN 1.4401 / AISI 316	EN 1.4401 / AISI 316

ISO End Suction Centrifugal Pump - GIS (Close Coupled) Pump Material Configuration

Standard Material

Pump Casing	Pump Cover	Motor Adapter	Impeller	Shaft	Wear Ring	Impeller Key	Impeller Nut
EN-GJL-250	EN-GJL-250	EN-GJL-250	EN 1.4301 / AISI 304	EN 1.4021 / AISI 420	EN 1.4301 / AISI 304	EN 1.4021 / AISI 420	EN 1.4301 / AISI 304

Optional Material

Pump Casing	Pump Cover	Motor Adapter	Impeller	Shaft	Wear Ring	Impeller Key	Impeller Nut
EN-GJL-250	EN-GJL-250	EN-GJL-250	EN-GJL-250	EN 1.4021 / AISI 420	EN 1.4301 / AISI 304	EN 1.4021 / AISI 420	EN 1.4301 / AISI 304
EN-GJS-450-10	EN-GJS-450-10	EN-GJL-250	EN-GJL-250	EN 1.4021 / AISI 420	EN 1.4301 / AISI 304	EN 1.4021 / AISI 420	EN 1.4301 / AISI 304
EN-GJL-250	EN-GJL-250	EN-GJL-250	CuSn10	EN 1.4021 / AISI 420	CuSn10	EN 1.4021 / AISI 420	EN 1.4301 / AISI 304
EN 1.4301 / AISI 304	EN 1.4301 / AISI 304	EN-GJL-250	EN 1.4301 / AISI 304	EN 1.4301 / AISI 304	EN 1.4301 / AISI 304	EN 1.4301 / AISI 304	EN 1.4301 / AISI 304
EN 1.4401 / AISI 316	EN 1.4401 / AISI 316	EN-GJL-250	EN 1.4401 / AISI 316	EN 1.4401 / AISI 316	EN 1.4401 / AISI 316	EN 1.4401 / AISI 316	EN 1.4401 / AISI 316
EN 1.4462 / UNS S32205	EN 1.4462 / UNS S32205	EN-GJL-250	EN 1.4462 / UNS S32205	EN 1.4462 / UNS S32205	EN 1.4462 / UNS S32205	EN 1.4462 / UNS S32205	EN 1.4462 / UNS S32205

ISO End Suction Centrifugal Pump - Technical Data (Standard Construction)

A. Pump	Unit	50-32-160	50-32-200	65-50-160	65-40-200
1. Water outlet	mm	32	32	50	40
2. Water inlet	mm	50	50	65	65
3. Flange hole		AS2129-1982 Table "E" PN16 standard			
4. Impeller structure		Single-suction double-seal-ring type			
5. Mean thickness of pump casing	mm	8	8	8	8
6. Pole number of pump		1	1	1	1
7. Pump casing structure		Radial-split back-pulling type			
8. Weight of pump head	Kg	38	46	40	48
9. Total delivery quantity	m ³	0.0326	0.038	0.0326	0.0437
10. Bearing type		1	1	1	1

B. Impeller and motor	Unit	50-32-160	50-32-200	65-50-160	65-40-200
1. Max. impeller diameter	mm	182	228	182	228
2. Weight of impeller (Bronze)	Kg	5.5	6.5	5.4	8.4
Weight of impeller (SS304)	Kg	5.1	6.0	5.0	7.8
3. Weight of bearing	Kg	0.464	0.464	0.464	0.464
4. Max. redundancy of friction ring	mm	0.3054	0.3054	0.3054	0.3054
Min. redundancy of friction ring	mm	0.3	0.3	0.3	0.3
5. Inner diameter of friction ring	mm	92	92	92	92
6. Square ring	mm	57	60	70	69
7. Area of square ring	cm ²	25.52	28.27	38.48	37.39
8. Max. rotation inertia (Bronze)	Kg.m ²	0.0149	0.0292	0.0166	0.0325
Max. rotation inertia (SS304)	Kg.m ²	0.0131	0.0258	0.0146	0.0287

Shaft and bearing	Unit	50-32-160	50-32-200	65-50-160	65-40-200
1. Shaft diameter (at impeller)	mm	25	25	25	25
2. Shaft diameter (at coupling)	mm	24	24	24	24
3. Bearing center distance	mm	154	154	154	154
4. The 1st critical rotation speed	RPM	8.76 x 10 ²	8.28 x 10 ²	8.53 x 10 ²	8.04 x 10 ²
5. Bearing type (drive end)		6306ZZ (30x72x19)			
6. Bearing type (pump head end)		6307ZZ (35x80x21)			

Mechanical seal	Unit	50-32-160	50-32-200	65-50-160	65-40-200
1. Material of mechanical seal		Graphite / ceramic / fluorine rubber (dynamic / static ring / rubber)			
2. Specification of mechanical seal	mm	32			

Operation limits	Unit	50-32-160	50-32-200	65-50-160	65-40-200
1. Max. operating pressure	Bar	16	16	16	16
2. Max. water flow pressure	Bar	24	24	24	24
3. Max. intake water pressure	Bar	7.5	6	7.5	6
4. Service life of bearing (calculated)	Hours	44385	43125	44000	42560
5. Max. temperature of mechanical seal	Deg C	100	100	100	100
6. Max. speed (drive end)	RPM	3600	3600	3600	3600
7. Max. speed (transmission end)	RPM	2900	2900	2900	2900

ISO End Suction Centrifugal Pump - Technical Data (Standard Construction)

A. Pump	Unit	65-40-250	65-40-315	80-65-160	80-65-200
1. Water outlet	mm	40	40	65	50
2. Water inlet	mm	65	65	80	80
3. Flange hole		AS2129-1982 Table "E" PN16 standard			
4. Impeller structure		Single-suction double-seal-ring type			
5. Mean thickness of pump casing	mm	9	10	9	9
6. Pole number of pump		1	1	1	1
7. Pump casing structure		Radial-split back-pulling type			
8. Weight of pump head	Kg	70	80	46	52
9. Total delivery quantity	m ³	0.0778	0.0971	0.0437	0.0463
10. Bearing type		2	2	1	1

B. Impeller and motor	Unit	65-40-250	65-40-315	80-65-160	80-65-200
1. Max. impeller diameter	mm	278	342	162	228
2. Weight of impeller (Bronze)	Kg	9.8	18	5.4	8.4
Weight of impeller (SS304)	Kg	9.0	16.6	5.0	7.8
3. Weight of bearing	Kg	0.829	0.829	0.464	0.464
4. Max. redundancy of friction ring	mm	0.3054	0.3054	0.3054	0.3054
Min. redundancy of friction ring	mm	0.3	0.3	0.3	0.3
5. Inner diameter of friction ring	mm	105	105	105	105
6. Square ring	mm	77	74	88	87
7. Area of square ring	cm ²	46.57	43	60.82	59.45
8. Max. rotation inertia (Bronze)	Kg.m ²	0.0725	0.1901	0.0149	0.0325
Max. rotation inertia (SS304)	Kg.m ²	0.0639	0.1677	0.0131	0.0287

Shaft and bearing	Unit	50-32-160	50-32-200	65-50-160	65-40-200
1. Shaft diameter (at impeller)	mm	35	35	35	35
2. Shaft diameter (at coupling)	mm	32	32	32	32
3. Bearing center distance	mm	224	224	154	154
4. The 1st critical rotation speed	RPM	5.07×10^4	4.35×10^4	8.75×10^4	8.04×10^4
5. Bearing type (drive end)		6308ZZ (40x90x23)		6306ZZ (30x72x19)	
6. Bearing type (pump head end)		6309VVC3NS7 (40x100x25)		6307ZZ (35x80x21)	

Mechanical seal	Unit	65-40-250	65-40-315	80-65-160	80-65-200
1. Material of mechanical seal		Graphite / ceramic / fluorine rubber (dynamic / static ring / rubber)			
2. Specification of mechanical seal	mm	43		32	

Operation limits	Unit	65-40-250	65-40-315	80-65-160	80-65-200
1. Max. operating pressure	Bar	16	16	16	16
2. Max. water flow pressure	Bar	24	24	24	24
3. Max. intake water pressure	Bar	3.5	2	7.5	6
4. Service life of bearing (calculated)	Hours	39285	35670	41550	39684
5. Max. temperature of mechanical seal	Deg C	100	100	100	100
6. Max. speed (drive end)	RPM	3600	3000	3600	3600
7. Max. speed (transmission end)	RPM	2480	1600	2900	2900

ISO End Suction Centrifugal Pump - Technical Data (Standard Construction)

A. Pump	Unit	80-50-250	80-50-315	100-80-160	100-65-200
1. Water outlet	mm	50	50	60	65
2. Water inlet	mm	80	80	100	100
3. Flange hole		AS2129-1982 Table "E" PN16 standard			
4. Impeller structure		Single-suction double-seal-ring type			
5. Mean thickness of pump casing	mm	9	12	9	9
6. Pole number of pump		1	1	1	1
7. Pump casing structure		Radial-split back-pulling type			
8. Weight of pump head	Kg	72	67	68	70
9. Total delivery quantity	m ³	0.061	0.1089	0.0605	0.0778
10. Bearing type		2	2	2	2

B. Impeller and motor	Unit	80-50-250	80-50-315	100-80-160	100-65-200
1. Max. impeller diameter	mm	278	342	182	228
2. Weight of impeller (Bronze)	Kg	12.5	14	7.2	10.5
Weight of impeller (SS304)	Kg	11.5	12.9	6.6	9.7
3. Weight of bearing	Kg	0.829	0.829	0.829	0.829
4. Max. redundancy of friction ring	mm	0.404	0.404	0.413	0.413
Min. redundancy of friction ring	mm	0.35	0.35	0.35	0.35
5. Inner diameter of friction ring	mm	115	115	132	132
6. Square ring	mm	66	90	112	112
7. Area of square ring	cm ²	58.09	63.62	98.52	98.52
8. Max. rotation inertia (Bronze)	Kg.m ²	0.0734	0.1842	0.0232	0.0448
Max. rotation inertia (SS304)	Kg.m ²	0.0647	0.1625	0.0205	0.0395

Shaft and bearing	Unit	80-50-250	80-50-315	100-80-160	100-65-200
1. Shaft diameter (at impeller)	mm	35	35	35	35
2. Shaft diameter (at coupling)	mm	32	32	32	32
3. Bearing center distance	mm	224	224	224	224
4. The 1st critical rotation speed	RPM	5.05×10^4	4.39×10^4	5.42×10^4	5.17×10^4
5. Bearing type (drive end)		6308ZZ (40x90x23)			
6. Bearing type (pump head end)		6309ZZ (45x100x25)			

Mechanical seal	Unit	80-50-250	80-50-315	100-80-160	100-65-200
1. Material of mechanical seal		Graphite / ceramic / fluorine rubber (dynamic / static ring / rubber)			
2. Specification of mechanical seal	mm	43			

Operation limits	Unit	80-50-250	80-50-315	100-80-160	100-65-200
1. Max. operating pressure	Bar	16	16	16	16
2. Max. water flow pressure	Bar	24	24	24	24
3. Max. intake water pressure	Bar	3.5	2	7.5	6
4. Service life of bearing (calculated)	Hours	36578	30867	43056	38057
5. Max. temperature of mechanical seal	Deg C	100	100	100	100
6. Max. speed (drive end)	RPM	3600	3000	3600	3600
7. Max. speed (transmission end)	RPM	2050	2800	2850	2250

ISO End Suction Centrifugal Pump - Technical Data (Standard Construction)

A. Pump	Unit	100×65-250	100×65-315	125×80-400	125×100-200
1. Water outlet	mm	65	65	80	100
2. Water inlet	mm	100	100	125	125
3. Flange hole		AS2129-1982 Table "E" PN16 standard			
4. Impeller structure		Single-suction double-seal-ring type			
5. Mean thickness of pump casing	mm	10	12	15	12
6. Pole number of pump		1	1	1	1
7. Pump casing structure		Radial-split back-pulling type			
8. Weight of pump head	Kg	80	118	165	85
9. Total delivery quantity	m ³	0.1013	0.1324	0.181	0.106
10. Bearing type		2	3	3	2

B. Impeller and motor	Unit	100×65-250	100×65-315	125×80-400	125×100-200
1. Max. impeller diameter	mm	278	342	438	228
2. Weight of impeller (Bronze)	Kg	10.2	16.6	28	9.2
Weight of impeller (SS304)	Kg	9.4	15.3	25.8	8.5
3. Weight of bearing	Kg	0.829	1.37	1.37	0.829
4. Max. redundancy of friction ring	mm	0.413	0.463	0.522	0.463
Min. redundancy of friction ring	mm	0.35	0.4	0.45	0.4
5. Inner diameter of friction ring	mm	132	160	186	160
6. Square ring	mm	108	125	127	133
7. Area of square ring	cm ²	91.61	122.72	126.68	138.93
8. Max. rotation inertia (Bronze)	Kg.m ²	0.0734	0.2047	0.6235	0.0533
Max. rotation inertia (SS304)	Kg.m ²	0.0647	0.1806	0.5499	0.0470

Shaft and bearing	Unit	100×65-250	100×65-315	125×80-400	125×100-200
1. Shaft diameter (at impeller)	mm	35	45	45	35
2. Shaft diameter (at coupling)	mm	32	42	42	32
3. Bearing center distance	mm	224	192	192	224
4. The 1st critical rotation speed	RPM	5.05×10^4	7.51×10^4	8.24×10^4	4.96×10^4
5. Bearing type (drive end)		6308ZZ (40x90x23)		6310ZZ (50x110x27)	6308ZZ (40x90x23)
6. Bearing type (pump head end)		6309ZZ (45x100x25)		6311ZZ (55x120x28)	6309ZZ (45x100x25)

Mechanical seal	Unit	100-65-250	100-65-315	125-80-400	125-100-200
1. Material of mechanical seal		Graphite / ceramic / fluorine rubber (dynamic / static ring / rubber)			
2. Specification of mechanical seal	mm	43		53	43

Operation limits	Unit	100-65-250	100-65-315	125-80-400	125-100-200
1. Max. operating pressure	Bar	16	16	16	16
2. Max. water flow pressure	Bar	24	24	24	24
3. Max. intake water pressure	Bar	3.5	2	7	6
4. Service life of bearing (calculated)	Hours	28557	18000	38150	28345
5. Max. temperature of mechanical seal	Deg C	100	100	100	100
6. Max. speed (drive end)	RPM	3600	3000	2350	3600
7. Max. speed (transmission end)	RPM	2190	1450	1450	2060

ISO End Suction Centrifugal Pump - Technical Data (Standard Construction)

A. Pump	Unit	125-100-250	125-100-315	125-100-400	125-100-500
1. Water outlet	mm	100	100	100	100
2. Water inlet	mm	125	125	125	125
3. Flange hole		AS2129-1982 Table "E" PN16 standard			
4. Impeller structure		Single-suction double-seal-ring type			
5. Mean thickness of pump casing	mm	11	15	15	19
6. Pole number of pump		1	1	1	1
7. Pump casing structure		Radial-split back-pulling type			
8. Weight of pump head	Kg	126	135	175	313
9. Total delivery quantity	m ³	0.1354	0.1515	0.2128	0.3875
10. Bearing type		3	3	3	4

B. Impeller and motor	Unit	125-100-250	125-100-315	125-100-400	125-100-500
1. Max. impeller diameter	mm	278	274	438	438
2. Weight of impeller (Bronze)	Kg	15.2	19.8	28	39.5
Weight of impeller (SS304)	Kg	14.0	18.3	25.8	36.5
3. Weight of bearing	Kg	1.37	1.37	1.37	2.11
4. Max. redundancy of friction ring	mm	0.522	0.463	0.522	0.463
Min. redundancy of friction ring	mm	0.45	0.4	0.45	0.4
5. Inner diameter of friction ring	mm	186	160	186	170
6. Square ring	mm	138	137	140	158
7. Area of square ring	cm ²	148.57	147.41	153.94	198.07
8. Max. rotation inertia (Bronze)	Kg.m ²	0.1256	0.1314	0.5995	0.8633
Max. rotation inertia (SS304)	Kg.m ²	0.1108	0.1159	0.5288	0.7615

Shaft and bearing	Unit	125-100-250	125-100-315	125-100-400	125-100-500
1. Shaft diameter (at impeller)	mm	45	45	45	53
2. Shaft diameter (at coupling)	mm	42	42	42	48
3. Bearing center distance	mm	192	192	192	258
4. The 1st critical rotation speed	RPM	7.65×10^4	7.51×10^4	6.32×10^4	4.26×10^4
5. Bearing type (drive end)		6310ZZ (50x120x27)		6313ZZ (65x140x33)	
6. Bearing type (pump head end)		6311ZZ (55x120x29)		6313ZZ (65x140x33)	

Mechanical seal	Unit	125-100-250	125-100-315	125-100-400	125-100-500
1. Material of mechanical seal		Graphite / ceramic / fluorine rubber (dynamic / static ring / rubber)			
2. Specification of mechanical seal	mm	53		60	

Operation limits	Unit	125-100-250	125-100-315	125-100-400	125-100-500
1. Max. operating pressure	Bar	16	16	16	16
2. Max. water flow pressure	Bar	24	24	24	24
3. Max. intake water pressure	Bar	3.5	2	7	4.5
4. Service life of bearing (calculated)	Hours	18122	17500	35450	29450
5. Max. temperature of mechanical seal	Deg C	100	100	100	100
6. Max. speed (drive end)	RPM	3000	3000	2350	1800
7. Max. speed (transmission end)	RPM	1620	1380	1240	1240

ISO End Suction Centrifugal Pump - Technical Data (Standard Construction)

A. Pump	Unit	150-125-250	150-125-315	150-125-400	150-125-500
1. Water outlet	mm	125	125	115	125
2. Water inlet	mm	150	150	150	150
3. Flange hole		AS2129-1982 Table "E" PN16 standard			
4. Impeller structure		Single-suction double-seal-ring type			
5. Mean thickness of pump casing	mm	14	15	16	20
6. Pole number of pump		1	1	1	1
7. Pump casing structure		Radial-split back-pulling type			
8. Weight of pump head	Kg	140	150	196	336
9. Total delivery quantity	m ³	0.1622	0.2128	0.2396	0.3675
10. Bearing type		3	3	3	4

B. Impeller and motor	Unit	150-125-250	150-125-315	150-125-400	150-125-500
1. Max. impeller diameter	mm	278	342	438	438
2. Weight of impeller (Bronze)	Kg	15.2	20.2	28.5	42.5
Weight of impeller (SS304)	Kg	14.0	18.6	26.3	39.2
3. Weight of bearing	Kg	1.37	1.37	1.37	2.11
4. Max. redundancy of friction ring	mm	0.522	0.522	0.522	0.522
Min. redundancy of friction ring	mm	0.45	0.45	0.45	0.45
5. Inner diameter of friction ring	mm	186	186	186	200
6. Square ring	mm	154	160	170	175
7. Area of square ring	cm ²	186.27	201.06	226.98	240.53
8. Max. rotation inertia (Bronze)	Kg.m ²	0.1159	0.2396	0.5516	0.9592
Max. rotation inertia (SS304)	Kg.m ²	0.1022	0.2113	0.4865	0.8460

Shaft and bearing	Unit	150-125-250	150-125-315	150-125-400	150-125-500
1. Shaft diameter (at impeller)	mm	45	45	45	53
2. Shaft diameter (at coupling)	mm	42	42	42	48
3. Bearing center distance	mm	192	192	192	258
4. The 1st critical rotation speed	RPM	7.81×10^4	7.19×10^4	8.5×10^4	4.11×10^4
5. Bearing type (drive end)		6310ZZ (50x110x27)		6313ZZ (65x140x33)	
6. Bearing type (pump head end)		6311ZZ (55x120x29)		6313ZZ (65x140x33)	

Mechanical seal	Unit	150-125-250	150-125-315	150-125-400	150-125-500
1. Material of mechanical seal		Graphite / ceramic / fluorine rubber (dynamic / static ring / rubber)			
2. Specification of mechanical seal	mm	53		60	

Operation limits	Unit	150-125-250	150-125-315	150-125-400	150-125-500
1. Max. operating pressure	Bar	16	16	16	16
2. Max. water flow pressure	Bar	24	24	24	24
3. Max. intake water pressure	Bar	3.5	2	7	4.5
4. Service life of bearing (calculated)	Hours	42000	39235	32000	24538
5. Max. temperature of mechanical seal	Deg C	100	100	100	100
6. Max. speed (drive end)	RPM	2350	2350	2350	1800
7. Max. speed (transmission end)	RPM	1440	1240	1060	1060

ISO End Suction Centrifugal Pump - Technical Data (Standard Construction)

A. Pump	Unit	200-150-315	200-150-400	200-150-500	250-200-315	250-200-400
1. Water outlet	mm	150	150	150	200	200
2. Water inlet	mm	200	200	200	250	250
3. Flange hole		AS2129-1982 Table "E" PN16 standard				
4. Impeller structure		Single-suction double-seal-ring type				
5. Mean thickness of pump casing	mm	16	18	22	17	19
6. Pole number of pump		1	1	1	1	1
7. Pump casing structure		Radial-split back-pulling type				
8. Weight of pump head	Kg	222	300	382	277	340
9. Total delivery quantity	m ³	0.3264	0.3493	0.4109	0.3577	0.3998
10. Bearing type		4	4	4	4	4

B. Impeller and motor	Unit	200-150-315	200-150-400	200-150-500	250-200-315	250-200-400
1. Max. impeller diameter	mm	342	438	547	342	438
2. Weight of impeller (Bronze)	Kg	23.2	42	51.6	34.6	37.6
Weight of impeller (SS304)	Kg	21.4	38.8	47.6	31.9	34.7
3. Weight of bearing	Kg	2.11	2.11	2.11	2.11	2.11
4. Max. redundancy of friction ring	mm	0.572	0.572	0.572	0.581	0.581
Min. redundancy of friction ring	mm	0.5	0.5	0.5	0.5	0.5
5. Inner diameter of friction ring	mm	235	235	235	265	265
6. Square ring	mm	210	206	212	232	232
7. Area of square ring	cm ²	346.36	333.29	352.99	422.73	422.73
8. Max. rotation inertia (Bronze)	Kg.m ²	0.2924	0.7434	1.533	0.3655	0.7554
Max. rotation inertia (SS304)	Kg.m ²	0.2579	0.6557	1.3521	0.3224	0.6663

Shaft and bearing	Unit	200-150-315	200-150-400	200-150-500	250-200-315	250-200-400
1. Shaft diameter (at impeller)	mm	53	53	53	53	53
2. Shaft diameter (at coupling)	mm	48	48	48	48	48
3. Bearing center distance	mm	258	258	258	258	258
4. The 1st critical rotation speed	RPM	5.01 x 10 ⁴	4.45 x 10 ⁴	4.08 x 10 ⁴	4.74 x 10 ⁴	4.43 x 10 ⁴
5. Bearing type (drive end)		6313 ZZ (65x140x33)				
6. Bearing type (pump head end)		6313 ZZ (65x140x33)				

Mechanical seal	Unit	200-150-315	200-150-400	200-150-500	250-200-315	250-200-400
1. Material of mechanical seal		Graphite / ceramic / fluorine rubber (dynamic / static ring / rubber)				
2. Specification of mechanical seal	mm	60				

Operation limits	Unit	200-150-315	200-150-400	200-150-500	250-200-315	250-200-400
1. Max. operating pressure	Bar	16	16	16	16	16
2. Max. water flow pressure	Bar	24	24	24	24	24
3. Max. intake water pressure	Bar	2	7	4.5	2	7
4. Service life of bearing (calculated)	Hours	28588	28676	21559	27689	23120
5. Max. temperature of mechanical seal	Deg C	100	100	100	100	100
6. Max. speed (drive end)	RPM	1800	1800	1800	1800	1800
7. Max. speed (transmission end)	RPM	1150	920	920	920	920

ISO End Suction Centrifugal Pump - Technical Data (Standard Construction)

A. Pump	Unit	400-300-460	400-300-550	400-350-480	400-400-410
1. Water outlet	mm	400	400	400	400
2. Water inlet	mm	300	300	350	400
3. Flange hole		AS2129-1982 Table "E" PN16 standard			
4. Impeller structure		Single-suction double-seal-ring type			
5. Mean thickness of pump casing	mm	20	20	20	20
6. Pole number of pump		1	1	1	1
7. Pump casing structure		Radial-split back-pulling type			
8. Weight of pump head	Kg	620	700	730	660
9. Total delivery quantity	m ³	0.973	1.073	1.218	1
10. Bearing type		5	5	5	5

B. Impeller and motor	Unit	400-300-460	400-300-550	400-350-480	400×400-410
1. Max. impeller diameter	mm	450	540	480	404
2. Weight of impeller (Bronze)	Kg	44	62	56	40
Weight of impeller (SS304)	Kg	40.6	57.2	51.7	36.9
3. Weight of bearing	Kg	3.05	3.05	3.05	3.06
4. Max. redundancy of friction ring	mm	0.389	0.389	0.489	0.389
Min. redundancy of friction ring	mm	0.3	0.3	0.4	0.3
5. Inner diameter of friction ring	mm	322	322	365	322
6. Square ring	mm	322	322	365	322
7. Area of square ring	cm ²	252.9	252.9	344	252.9
8. Max. rotation inertia (Bronze)	Kg.m ²	1.5188	2.8431	2.0736	1.1767
Max. rotation inertia (SS304)	Kg.m ²	1.3396	2.5077	1.8290	1.0379

Shaft and bearing	Unit	400-300-460	400-300-550	400-350-480	400-400-410
1. Shaft diameter (at impeller)	mm	60	60	60	60
2. Shaft diameter (at coupling)	mm	70	70	70	70
3. Bearing center distance	mm	297	297	297	297
4. The 1st critical rotation speed	RPM	5.07 x 10 ⁴	4.44 x 10 ⁴	4.62 x 10 ⁴	5.24 x 10 ⁴
5. Bearing type (drive end)		6315ZZ (75x160x37)			
6. Bearing type (pump head end)		6316ZZ (80x170x39)			

Mechanical seal	Unit	400-300-460	400-300-550	400-350-480	400-400-410
1. Material of mechanical seal		Graphite / ceramic / fluorine rubber (dynamic / static ring / rubber)			
2. Specification of mechanical seal	mm	75			

Operation limits	Unit	400-300-460	400-300-550	400-350-480	400-400-410
1. Max. operating pressure	Bar	16	16	16	16
2. Max. water flow pressure	Bar	24	24	24	24
3. Service life of bearing (calculated)	Hours	51999	23704	25472	80706
4. Max. temperature of mechanical seal	Deg C	100	100	100	100
5. Max. speed (drive end)	RPM	1200	1200	1200	1200
6. Max. speed (transmission end)	RPM	1180	1180	1180	1180

What can Xylem do for you?

Xylem |ˈzīləm| 1) the tissue in plants that brings water upward from the roots; 2) a leading global water technology company.

We're 12,000 people unified in a common purpose: creating innovative solutions to meet our world's water needs. Developing new technologies that will improve the way water is used, conserved, and re-used in the future is central to our work. We move, treat, analyze, and return water to the environment, and we help people use water efficiently, in their homes, buildings, factories and farms. In more than 150 countries, we have strong, long-standing relationships with customers who know us for our powerful combination of leading product brands and applications expertise, backed by a legacy of innovation.

For more information on how Xylem can help you, go to www.xyleminc.com



Korea
Xylem Water Solutions Korea Co., Ltd.
4F, Dong-A Building, 789
Yeoksam, Gangnam
Seoul, 135-929
Korea
Tel: +82.2.552.0553
Fax: +82.2.552.0557

Singapore
Xylem Water Solutions Singapore Pte Ltd.
1 Jalan Kilang Timor
#06-06
Singapore 159303
Tel: +65.6681.0166
Fax: +65.6681.0168

Australia
Xylem Water Systems Australia Pty Ltd.
Unit 3/1 Federation Way
Chifley Business Park
Mentone Victoria 3194
Australia
Tel: +61.3.9551.7333
Fax: +61.3.9551.0321

Philippines
Xylem Water Systems International, Inc.
12 Ring Road
LISP II
Calamba Laguna 4027
Philippines
Tel: +63.49.545.6810
Fax: +63.49.545.6817

Japan
Xylem Water Systems Japan Corporation
8-11-12 Higashi-Narashino
Chiba, 275-0001
Japan
Tel: +81.47.470.3451
Fax: +81.47.470.3453

Thailand
Xylem Water Systems International, Inc.
50/7 Moo 12 Bangna-Trad Road
KM.6 Bangkaew, Bangplee
Samutprakarn 10540
Thailand
Tel: +66.2740.2019
Fax: +66.2740.2019

Malaysia
Xylem Water Systems International, Inc.
Lot 59, Jalan Tanjung Medan 26/12
40000 Shah Alam
Selanor Darul Ehsan
Malaysia
Tel: +603.5191.3789
Fax: +603.5191.2424

China
Xylem Water Systems (Nanjing) Co., Ltd.
Room 1201, Zi Feng Tower (Side Building)
No. 8 Zhong Shan North Road
Gulou District, Nanjing 210009
China
Tel: +86.25.8351.8233
Fax: +86.25.8334.6953