



DLP、DLPT

Vertical Multistage
Pressed Stainless Steel Pump



Contents

* DLP1/DLPT1	9
* DLP2/DLPT2	11
* DLP3/DLPT3	13
* DLP4/DLPT4	15
* DLP5/DLPT5	17
* DLP8/DLPT8	19
* DLP10/DLPT10	21
* DLP12/DLPT12	23
* DLP15/DLPT15	25
* DLP16/DLPT16	27
* DLP20/DLPT20	29
* DLP32/DLPT32	31
* DLP45/DLPT45	33
* DLP64/DLPT64	35
* DLP90/DLPT90	37
* DLP120/DLPT120	39
* DLP150/DLPT150	41
* DLP200/DLPT200	43

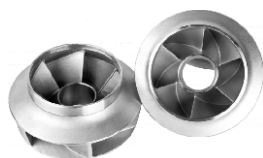

性能范围

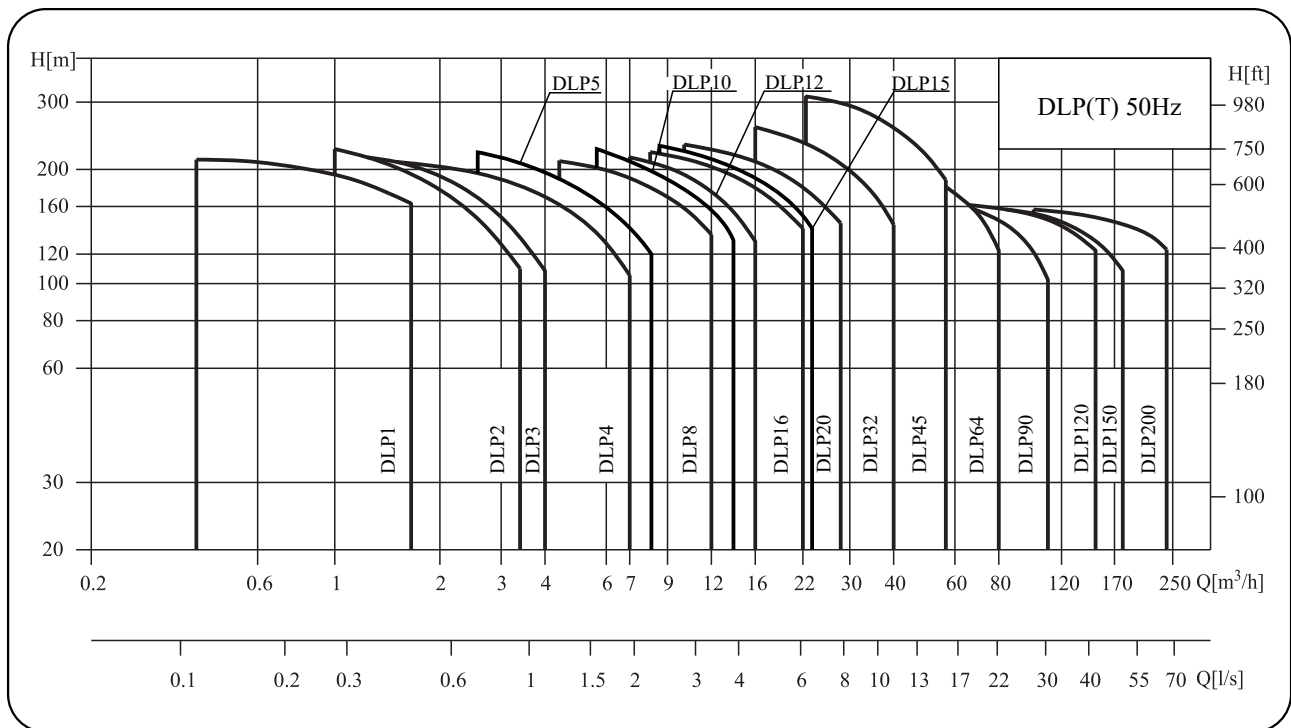

产品范围

主要参数	DLP1	DLP2	DLP3	DLP4	DLP5	DLP8	DLP10	DLP12	DLP15	DLP16	DLP20
额定流量[m³/h]	1	2	3	4	5	8	10	12	15	16	20
额定流量[l/s]	0.28	0.56	0.83	1.1	1.39	2.2	2.78	3.3	4.17	4.4	5.6
流量范围[m³/h]	0.4~1.8	1~3.5	1.2~4	1.5~7	2.5~8.5	5~12	5~13	7~16	8~23	8~22	10~28
流量范围[l/s]	0.11~0.5	0.28~0.97	0.33~1.1	0.42~1.9	0.69~2.36	1.39~3.3	1.39~3.61	1.9~4.4	2.22~6.39	2.2~6.1	2.8~7.8
最大压力[bar]	21	23	22	21	24	21	23	22	23	22	23
电机功率[kW]	0.37~2.2	0.37~3	0.37~3	0.37~4	0.37~5.5	0.75~7.5	0.75~7.5	1.5~11	1.1~15	2.2~15	1.1~18.5
温度范围[°C]	-15~105										
最高效率[%]	44	46	54	58	63	62	70	63	73	66	69
DLP管路连接											
DIN法兰	DN25	DN25	DN25	DN32	DN32	DN40	DN40	DN50	DN50	DN50	DN50
管螺纹	R1 1/4"	R1 1/4"	R1 1/4"	R1 1/4"	R1 1/4"	R1 2"	R1 2"	R1 2"	R1 2"	R1 2"	R1 2"
卡套接头	DN32	DN32	DN32	DN32	DN32	DN50	DN50	DN50	DN50	DN50	DN50
DLPT管路连接											
DIN法兰	DN25	DN25	DN25	DN32	DN32	DN40	DN40	DN50	DN50	DN50	DN50

主要参数	DLP32	DLP45	DLP64	DLP90	DLP120	DLP150	DLP200
额定流量[m ³ /h]	32	45	64	90	120	150	200
额定流量[l/s]	8.9	12.5	17.8	25	33.3	41.7	55.6
流量范围[m ³ /h]	16~40	25~55	30~80	50~110	60~150	80~180	100~240
流量范围[l/s]	4.4~11	6.9~15.3	8~22	14~30	17~42	22~50	28~67
最大压力[bar]	26	30	22	17	16	16	16
电机功率[kW]	1.5~30	3~45	4~45	5.5~45	11~75	11~75	18.5~110
温度范围[°C]	-15~105						
最高效率[%]	74	75	76	77	74	73	79
管路连接							
DIN法兰	DN65	DN80	DN100	DN100	DN125	DN125	DN150

型号含义

DLP, DLPT1/2/3/4/5/8/10/12/15/16/20

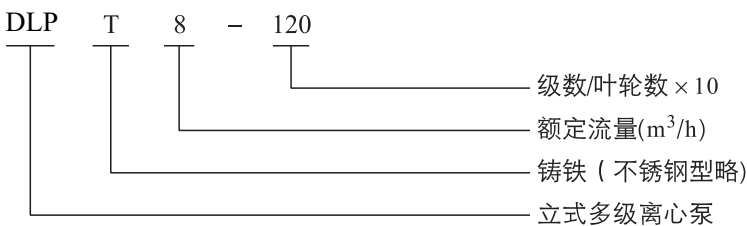

DLP, DLPT32/45/64/90/120/150

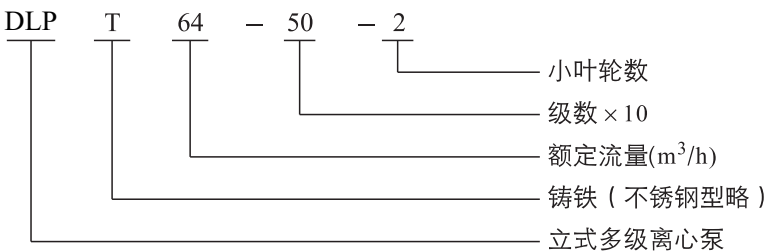

DLP, DLPT200

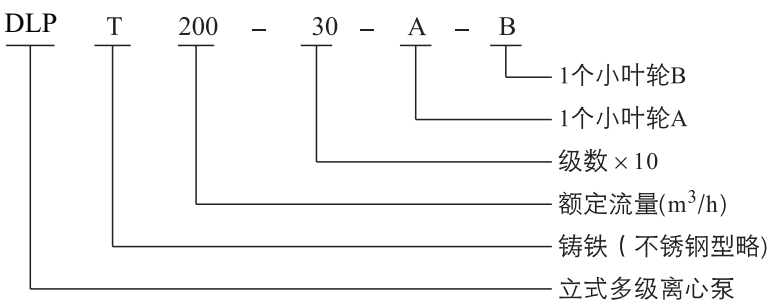

典型应用

●DLP, DLPT泵为立式多级离心泵, 其管道式结构可以确保泵可直接安装在进出在同一水平线上且管径相同的水平管路系统中, 这种设计使泵的结构和管路更为紧凑。

●敬峰DLP, DLPT泵有不同的泵规格和不同级数, 以满足所需的流量和压力。

●DLP(T) 是一种多功能产品, 可以输送从自来水到工业液体的各种不同介质, 适用于不同温度、流量和压力范围。

●DLPT 适用于无腐蚀性液体, DLP 适用于轻度腐蚀性液体。

●供水: 水厂过滤与输送、水厂分区送水、主管网增压、高层建筑、宾馆等的增压、工业给水增压。

●工业增压: 流程水系统、清洗系统、高压冲洗系统、消防系统、汽车清洗。

●工业液体输送: 冷却和空调系统、锅炉给水和冷凝系统、机床配套。

●输送: 油和酒精、酸和碱、乙二醇和冷却剂。

●水处理: 超滤系统、反渗透系统、蒸馏系统、分离器、游泳池。

●灌溉: 区域灌溉、喷灌、滴灌。

电机

- 电机为全封闭，风冷式二级标准电机
- 防护等级：IP55
- 绝缘等级：F
- 标准电压：50Hz: 1 × 220-230/240V
3 × 200-220/346-380V
3 × 220-240/380-415V
3 × 220-255/380-440V
- 其它电压的电机按要求可供。
- 单相电机从0.37 ~ 2.2 kW可供。

性能曲线

- 所有曲线都基于电机在恒速2900rpm 或2950rpm的测量值。
- 曲线容差符合ISO9906，附录A。
- 测试采用20℃不含空气的水，运动粘度1mm²/s。
- 泵的使用参照粗线的性能范围，以防流量过小产生过热或流量过大使电机过载等。

泵说明

- DLP(T) 为配有标准电机的非自吸立式多级离心泵，电机轴和泵轴用联轴器直接联接，把拉杆用螺母将外筒，过流部件固定在支架和进出水体之间，泵进出水口在泵底部的同一直线上。
- 泵可根据需要配置智能保护器，对泵的干转、缺相、过载等进行有效的保护。

海拔与环境温度

- 当泵在环境温度大于40℃或海拔大于1000m时运行，电机输出功率P₂会降低，所以泵在上述情况下，电机功率需配大。

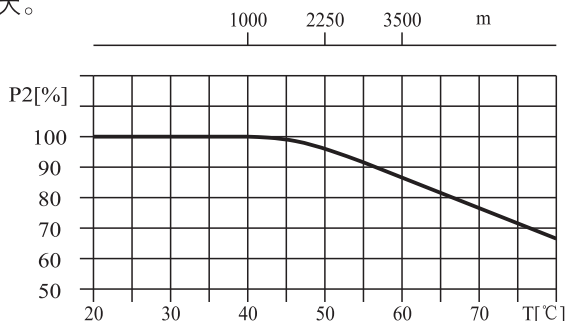

最大工作压力

- 下图表示压力和温度的极限，压力和温度须在所示范围内。

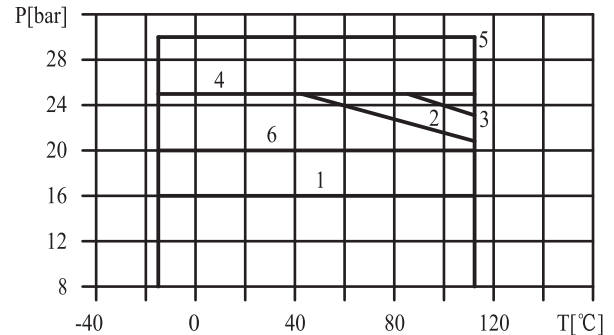

泵型号	曲线号	
DLP,DLPT1/2/3/4/5	2	
DLP,DLPT8/10/12/15/16/20	3	
DLP,DLPT32	32-10-1~32-70	1
	32-80-2~32-120	4
	32-130-2~32-160	5
DLP,DLPT45	45-10-1~45-60	1
	45-70-2~45-90	4
	45-100-2~45-130-2	5
DLP,DLPT64	64-10-1~64-50	1
	64-60-2~64-80-1	4
DLP,DLPT90	90-10-1~90-50-2	1
	90-50~90-60	4
DLP,DLPT120/150/200	6	

注:曲线4/5需特殊订货

运行条件

- 稀薄、干净、非易燃易爆并不含固体颗粒或纤维的液体。
- 液体温度：常温型-15℃ ~ +70℃
热水型-15℃ ~ +105℃
- 环境温度：最高 +40℃
- 海拔：最高1000m

结构图DLP, DLPT1、2、3、4、5

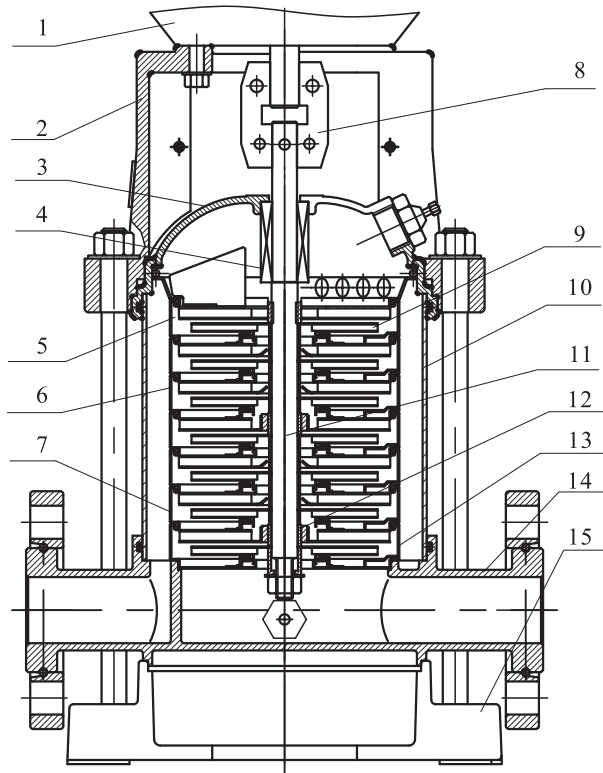

DLP

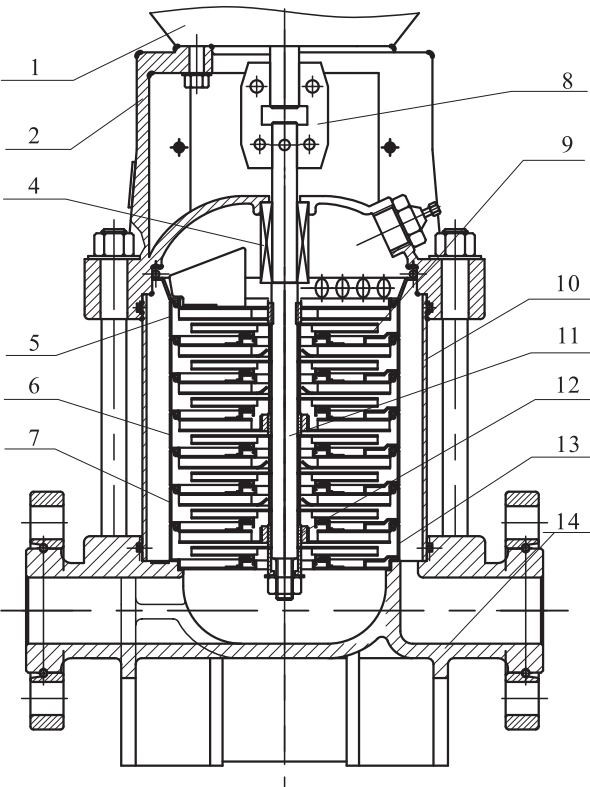

DLPT

材料DLP, DLPT1、2、3、4、5

序号	名称	材料	AISI/ASTM
1	电机	组合件	
2	支架	铸铁/球墨铸铁	ASTM25B ASTM70-50-05
4	机械密封	组合件	
5	出水导叶	不锈钢	AISI304
6	导叶	不锈钢	AISI304
7	支撑导叶	不锈钢	AISI304
8	联轴器	球墨铸铁	ASTM70-50-05
9	叶轮	不锈钢	AISI304
10	外筒	不锈钢	AISI304
11	泵轴	不锈钢	AISI304 AISI316L
12	轴承	碳化钨	
13	进水导叶	不锈钢	AISI304
DLP			
3	密封座	不锈钢	AISI304
14	进出水体	不锈钢	AISI304
15	底座	铸铁	ASTM25B
DLPT			
14	进出水体	铸铁	ASTM25B

结构图DLP,DLPT8、10、12、15、16、20 材料DLP,DLPT8、10、12、15、16、20

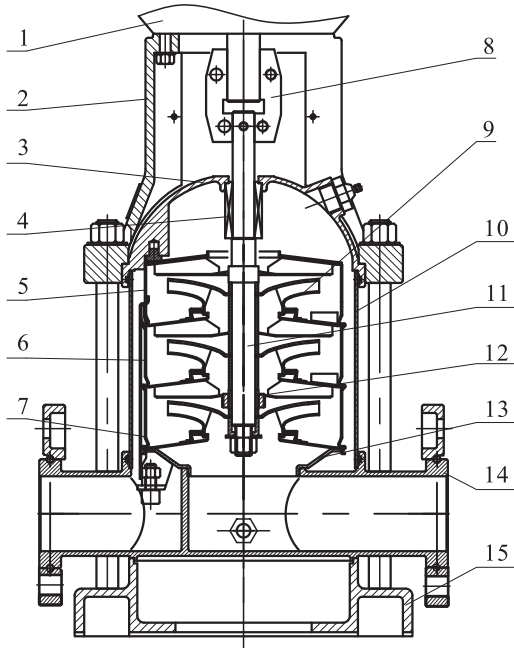

DLP

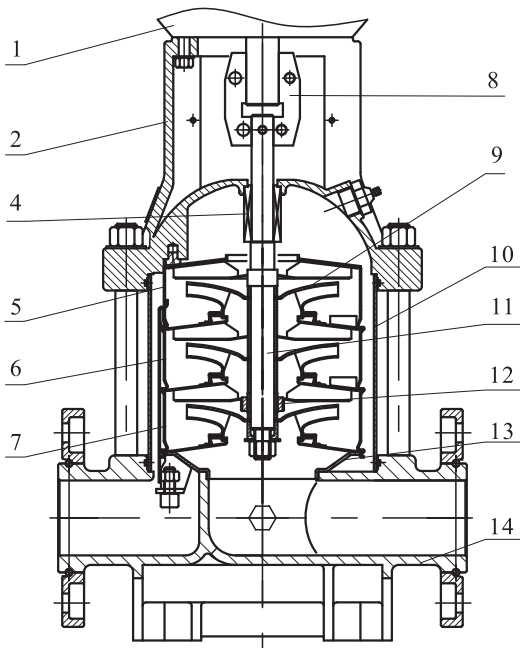

DLPT

序号	名称	材料	AISI/ASTM
1	电机	组合件	
2	支架	铸铁/球墨铸铁	ASTM25B ASTM70-50-05
4	机械密封	组合件	
5	出水导叶	不锈钢	AISI304
6	导叶	不锈钢	AISI304
7	支撑导叶	不锈钢	AISI304
8	联轴器	球墨铸铁	ASTM70-50-05
9	叶轮	不锈钢	AISI304
10	外筒	不锈钢	AISI304
11	泵轴	不锈钢	AISI304 AISI316L
12	轴承	碳化钨	
13	进水导叶	不锈钢	AISI304
DLP			
3	密封座	不锈钢	AISI304
14	进出水体	不锈钢	AISI304
15	底座	铸铁	ASTM25B
DLPT			
14	进出水体	铸铁	ASTM25B

结构图DLP,DLPT32、45、64、90

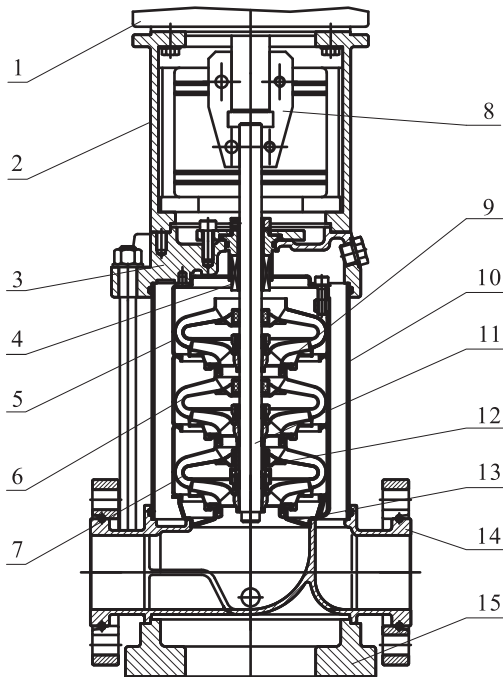

DLP

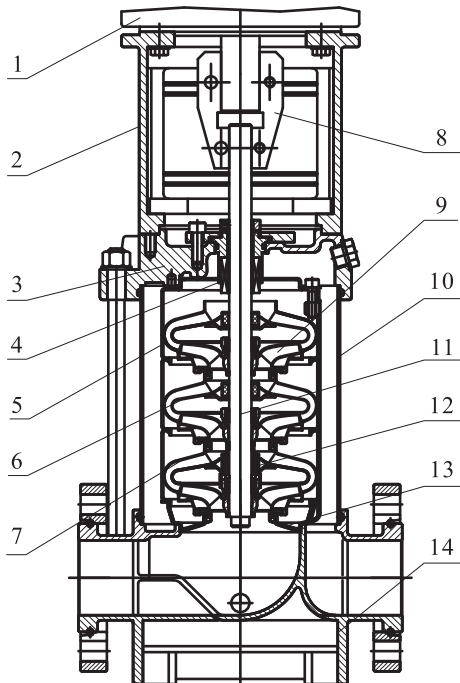

DLPT

材料DLP,DLPT32、45、64、90

序号	名称	材料	AISI/ASTM
1	电机	组合件	
2	支架	铸铁/球墨铸铁	ASTM25B
4	机械密封	组合件	
5	出水导叶	不锈钢	AISI304
6	导叶	不锈钢	AISI304
7	支撑导叶	不锈钢	AISI304
8	联轴器	球墨铸铁	ASTM70-50-05
9	叶轮	不锈钢	AISI304
10	外筒	不锈钢	AISI304
11	泵轴	不锈钢	AISI304 AISI316L AISI431
12	轴承	碳化钨	
13	进水导叶	不锈钢	AISI304
DLP			
3	密封座	不锈钢	AISI304
14	进出水体	不锈钢	AISI304
15	底座	铸铁	ASTM25B
DLPT			
3	密封座	铸铁/球墨铸铁	ASTM25B ASTM70-50-05
14	进出水体	铸铁/球墨铸铁	ASTM25B ASTM70-50-05

结构图DLP,DLPT120、150、200

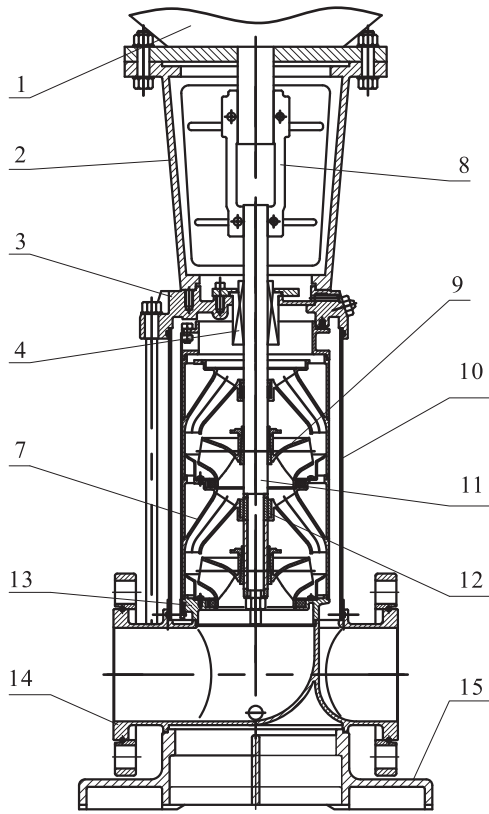

DLP

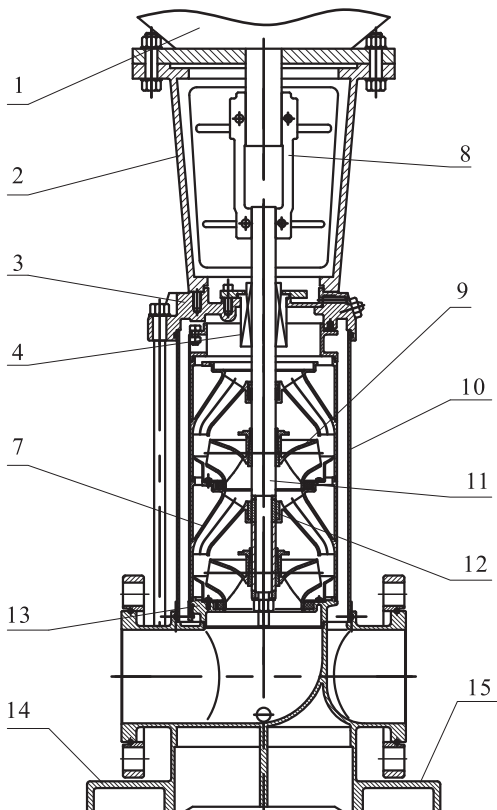

DLPT

材料DLP,DLPT120、150、200

序号	名称	材料	AISI/ASTM
1	电机	组合件	
2	支架	铸铁/球墨铸铁	ASTM25B ASTM70-50-05
4	机械密封	组合件	
7	支撑导叶	不锈钢	AISI304
8	联轴器	球墨铸铁	ASTM7-50-05
9	叶轮	不锈钢	AISI304
10	外筒	不锈钢	AISI304
11	泵轴	不锈钢	AISI304 AISI316L AISI431
12	轴承	碳化钨	
13	进水导叶	不锈钢	AISI304
15	底座	球墨铸铁	ASTM70-50-05
DLP			
3	密封座	不锈钢	AISI304
14	进出水体	不锈钢	AISI304
DLPT			
3	密封座	球墨铸铁	ASTM70-50-05
14	进出水体	铸铁/球墨铸铁	ASTM25B ASTM7-50-05

最小进口压力 NPSH

如果泵中的压力低于输送液体的汽化压力，可能发生气蚀，为避免气蚀，确保泵进口侧有一最小压力，最大吸程 H[m]可按下式计算：

$$H = P_b \times 10.2 - NPSH - H_f - H_v - H_s$$

P_b = 大气压力 [bar]

(大气压力可设定为 1 bar)

在闭式系统中， P_b 为系统压力 [bar]

NPSH = 净正吸头 [m]

(可从 NPSH 曲线上泵可能的最大流量处读取)

H_f = 入口的管路损失 [m]

H_v = 汽化压力 [m]

H_s = 安全余量 = 最小 0.5m 水头

如计算所得 H 为正值，泵可在最大吸程 H 情况下运行。

如计算所得 H 为负值，必须有一最小进口压力 H 的水头。

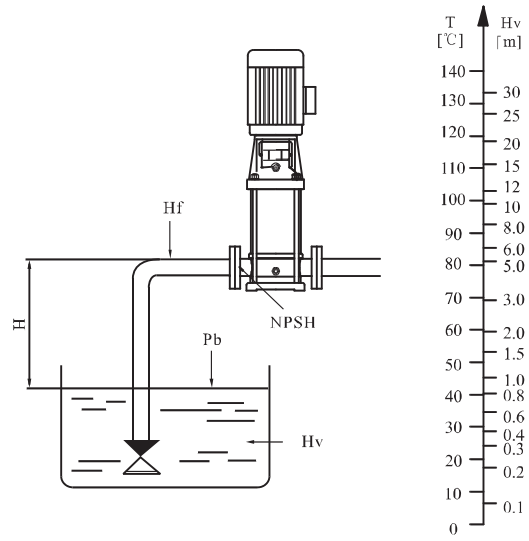

检查确保泵不会 / 没有处于气蚀状态

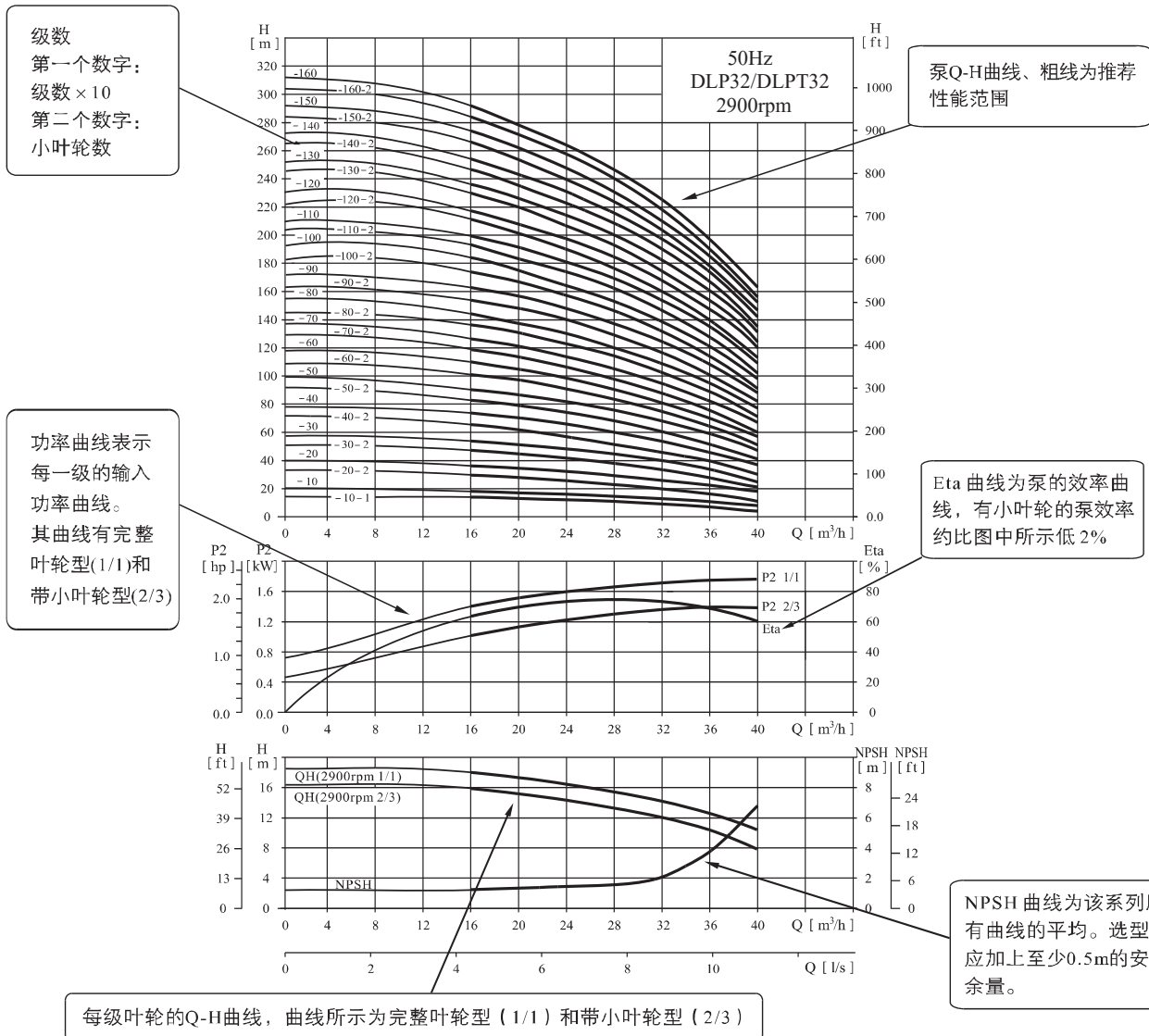

每级叶轮的 Q-H 曲线，曲线所示为完整叶轮型 (1/1) 和带小叶轮型 (2/3)

性能曲线

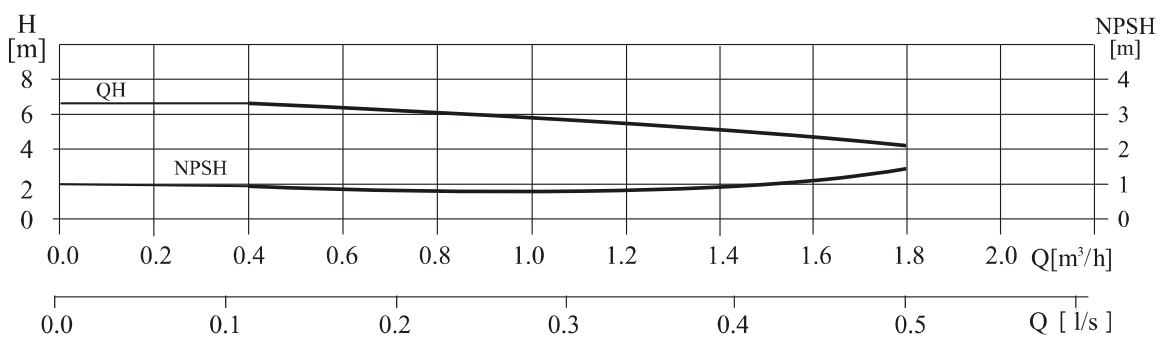
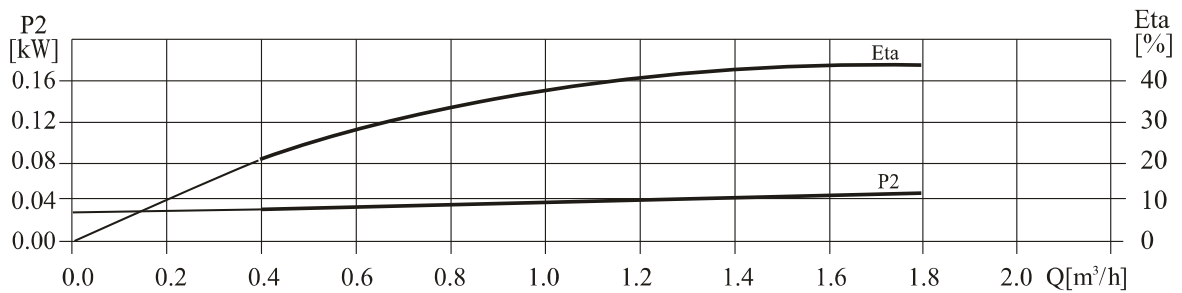
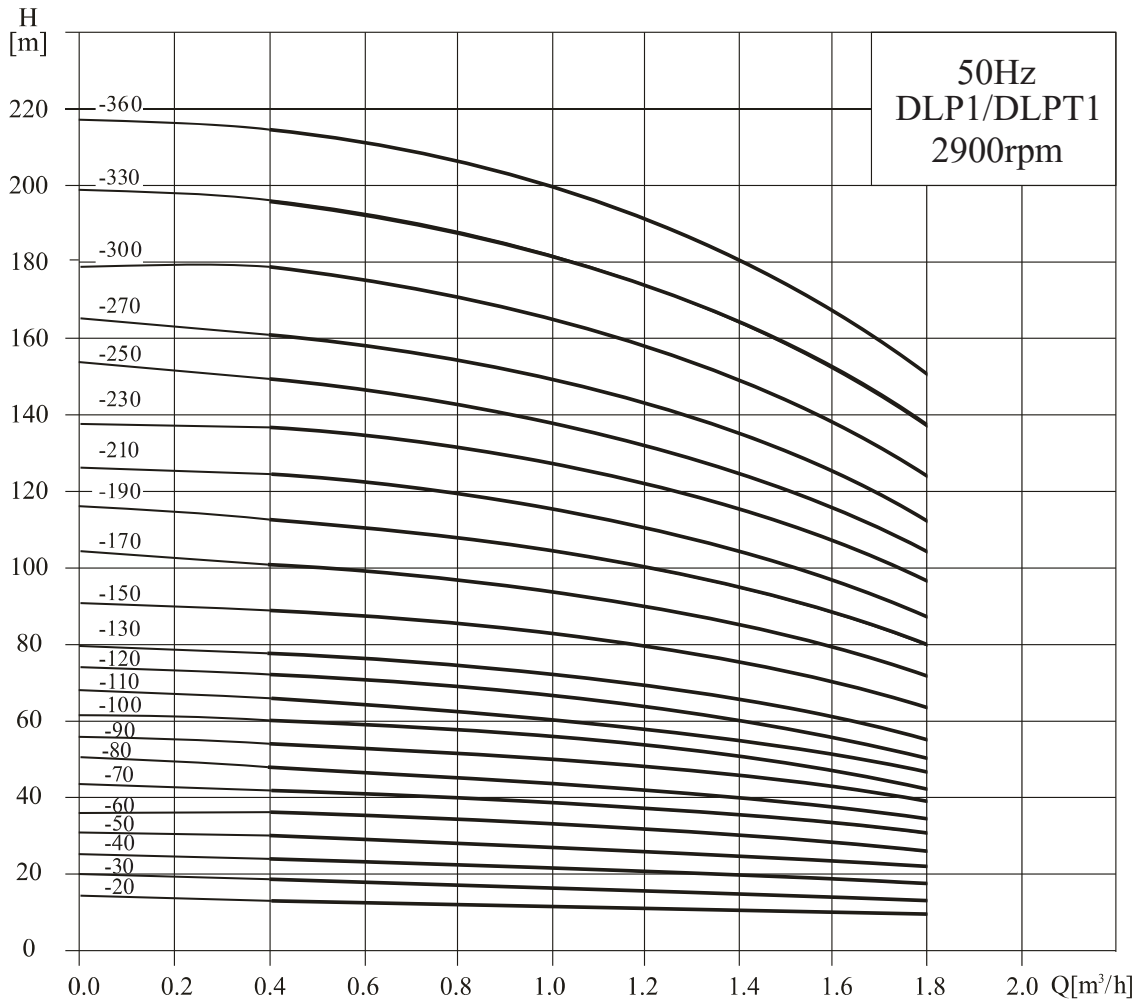

安装图

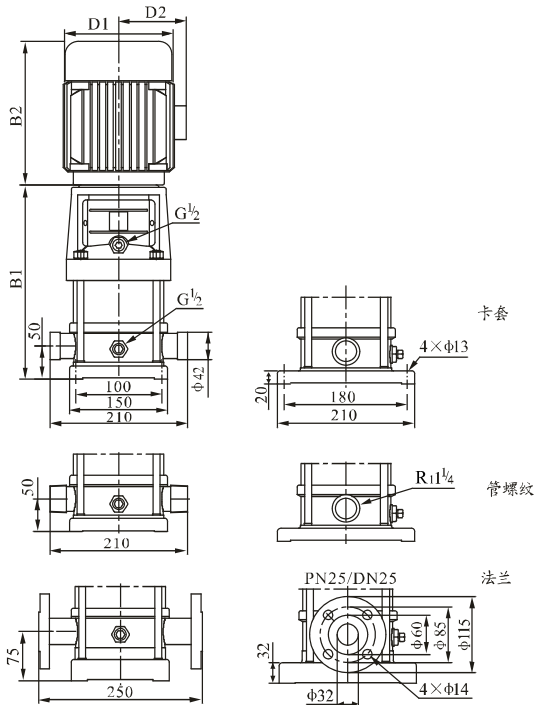

尺寸和重量

型号	尺寸(mm)					重量(kg)
	B1	B2	B1+B2	D1	D2	
DLP1-20	258	225	483	148	117	20
DLP1-30	276	225	501	148	117	20
DLP1-40	294	225	519	148	117	21
DLP1-50	312	225	537	148	117	21
DLP1-60	330	225	555	148	117	22
DLP1-70	348	225	573	148	117	23
DLP1-80	366	225	591	148	117	24
DLP1-90	384	225	609	148	117	25
DLP1-100	402	225	627	148	117	26
DLP1-110	420	225	645	148	117	26
DLP1-120	448	245	693	170	142	29
DLP1-130	466	245	711	170	142	30
DLP1-150	502	245	747	170	142	31
DLP1-170	538	245	783	170	142	33
DLP1-190	574	245	819	170	142	34
DLP1-210	610	245	855	170	142	35
DLP1-230	646	245	891	170	142	36
DLP1-250	692	290	982	190	155	42
DLP1-270	728	290	1018	190	155	43
DLP1-300	782	290	1072	190	155	45
DLP1-330	836	290	1126	190	155	49
DLP1-360	890	290	1180	190	155	51

性能表

型号	配用电机 (kW)	Q (m ³ /h)	0.4	0.6	0.8	1.0	1.2	1.4	1.6	1.8
DLP1-20	0.37	H (m)	13	12.5	12	11.5	11	10.5	10	9.5
DLP1-30	0.37		19	18	17.5	17	16.5	16	15	14
DLP1-40	0.37		24	23.5	23	22.5	21.5	21	19	18
DLP1-50	0.37		30	29.6	29	28	27	26	24	22
DLP1-60	0.37		36	35.5	35	33.5	33	31	28	26
DLP1-70	0.37		42	41	40.5	39	38	36	33	30
DLP1-80	0.55		48	47	46	45	43	41	38	34
DLP1-90	0.55		54	53	52	51	49	46	43	39
DLP1-100	0.55		60	59	58	57	54	51	48	43
DLP1-110	0.55		66	65	63	61	59	56	52	47
DLP1-120	0.75		72	71	69	67	64	61	57	51
DLP1-130	0.75		78	77	75	73	69	66	62	55
DLP1-150	0.75		89	88	86	84	79	76	71	63
DLP1-170	1.1		101	99	97	95	89	86	80	71
DLP1-190	1.1		113	110	108	106	99	96	89	79
DLP1-210	1.1		124	122	120	117	110	106	98	87
DLP1-230	1.1		137	133	131	128	121	116	107	96
DLP1-250	1.5		149	145	143	139	131	126	116	104
DLP1-270	1.5	161	157	155	150	141	136	125	112	
DLP1-300	1.5	178	175	171	166	157	150	139	124	
DLP1-330	2.2	196	192	188	183	173	165	154	137	
DLP1-360	2.2	214	210	205	200	190	181	169	151	

单相电机、隔爆电机外形尺寸有所变动，详情请咨询本公司。

性能曲线

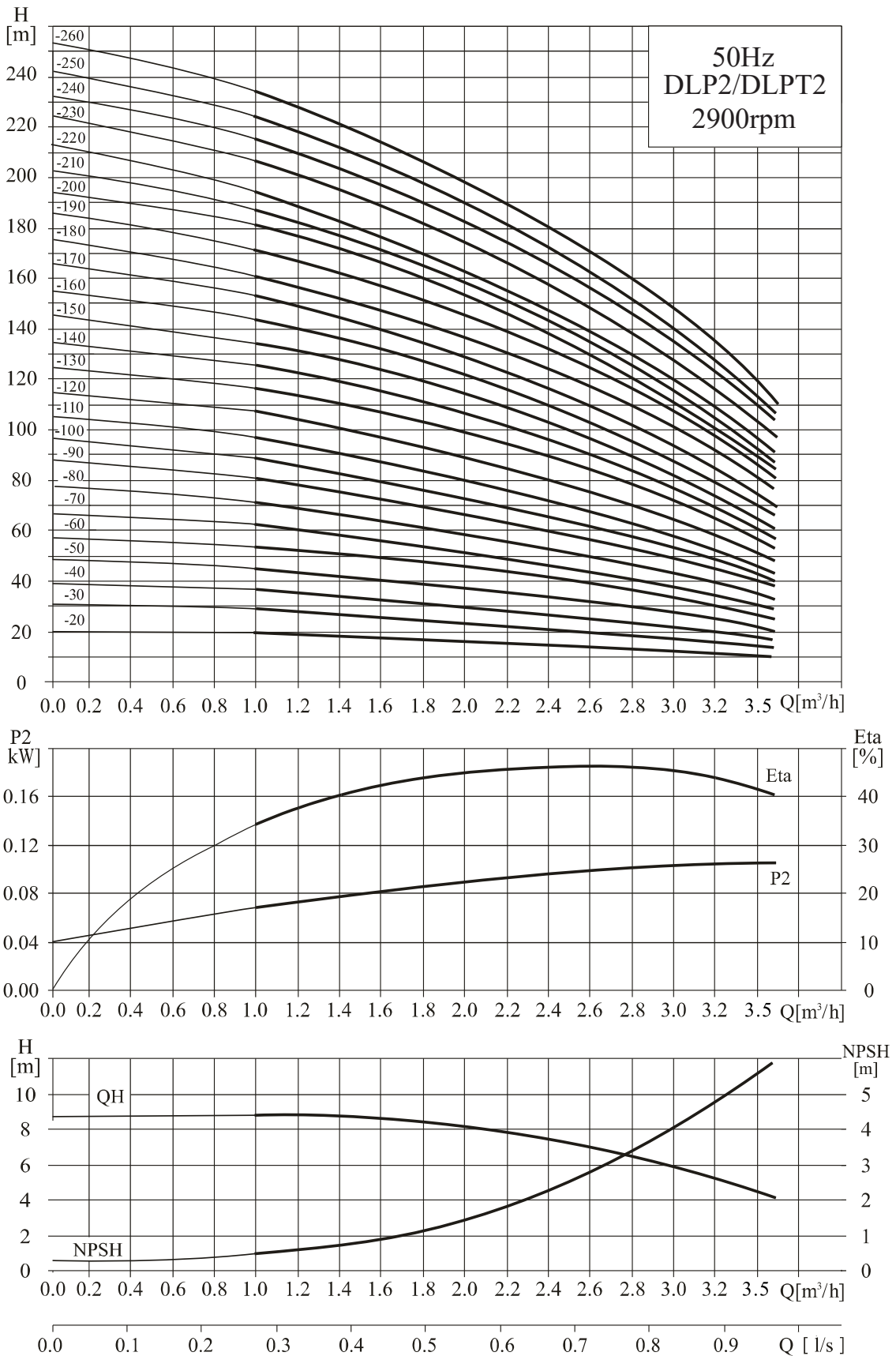

安装图

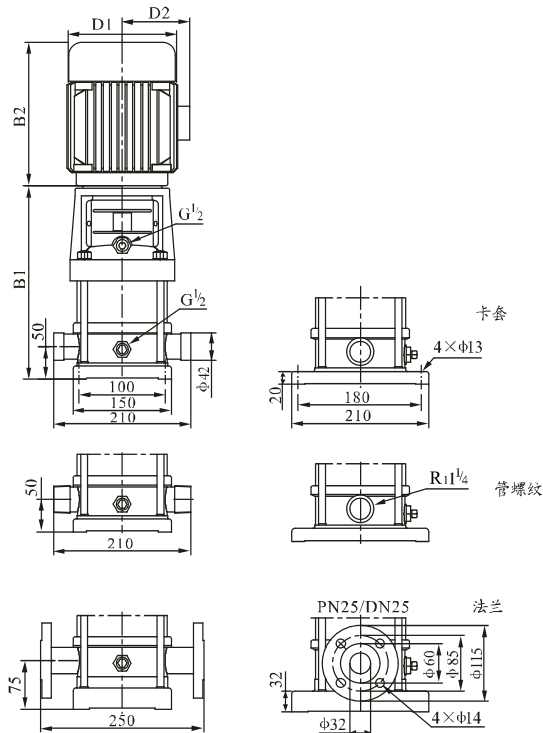

尺寸和重量

型号	尺寸(mm)					重量(kg)
	B1	B2	B1+B2	D1	D2	
DLP2-20	258	225	483	148	117	20
DLP2-30	276	225	501	148	117	20
DLP2-40	294	225	519	148	117	22
DLP2-50	312	225	537	148	117	23
DLP2-60	340	245	585	170	142	26
DLP2-70	358	245	603	170	142	26
DLP2-90	394	245	639	170	142	28
DLP2-110	430	245	675	170	142	29
DLP2-130	476	290	766	190	155	35
DLP2-150	512	290	802	190	155	36
DLP2-180	566	290	856	190	155	41
DLP2-220	638	290	928	190	155	42
DLP2-260	720	345	1065	197	165	52

性能表

型号	配用电机 (kW)	Q (m ³ /h)	H (m)							
			1	1.2	1.6	2.0	2.4	2.8	3.2	3.5
DLP2-20	0.37	H (m)	18	17	16	15	13	12	10	8
DLP2-30	0.37		27	26	24	22	20	18	15	12
DLP2-40	0.55		36	35	33	30	26	24	20	16
DLP2-50	0.55		45	43	40	37	33	30	24	20
DLP2-60	0.75		53	52	50	45	40	36	30	24
DLP2-70	0.75		63	61	57	52	47	41	35	28
DLP2-90	1.1		80	78	73	67	61	54	45	37
DLP2-110	1.1		98	95	89	82	73	64	54	44
DLP2-130	1.5		116	114	106	98	89	78	65	52
DLP2-150	1.5		134	130	123	112	100	90	73	60
DLP2-180	2.2		161	157	148	136	121	108	91	76
DLP2-220	2.2		197	192	180	165	148	130	110	90
DLP2-260	3.0		232	228	214	198	179	158	130	110

单相电机、隔爆电机外形尺寸有所变动，详情请咨询本公司。

性能曲线

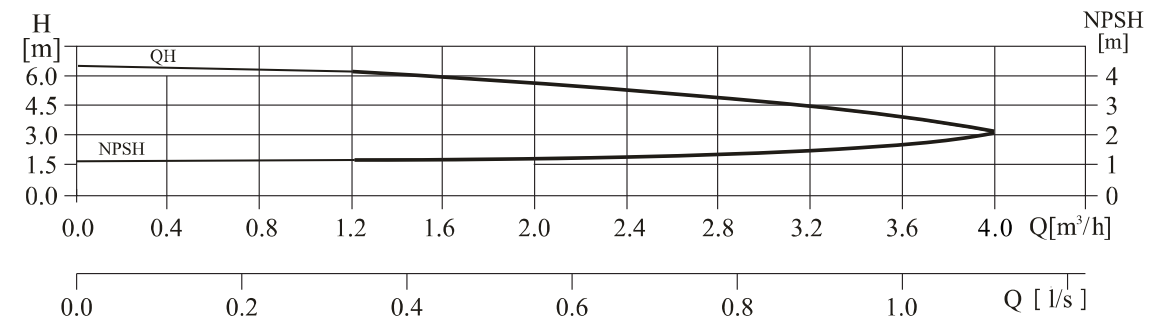
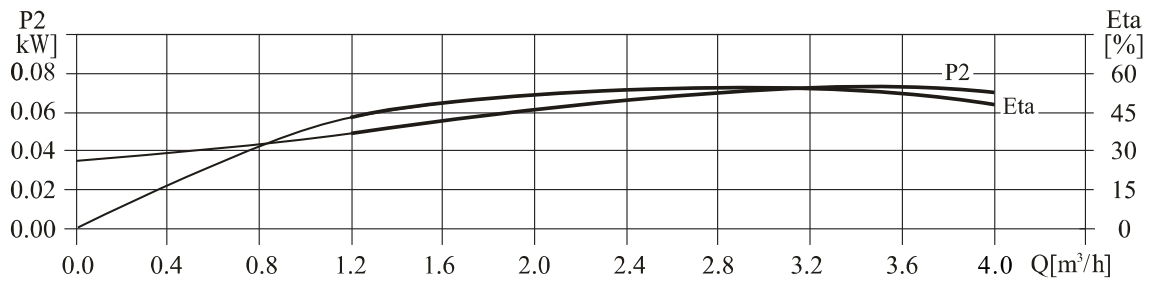
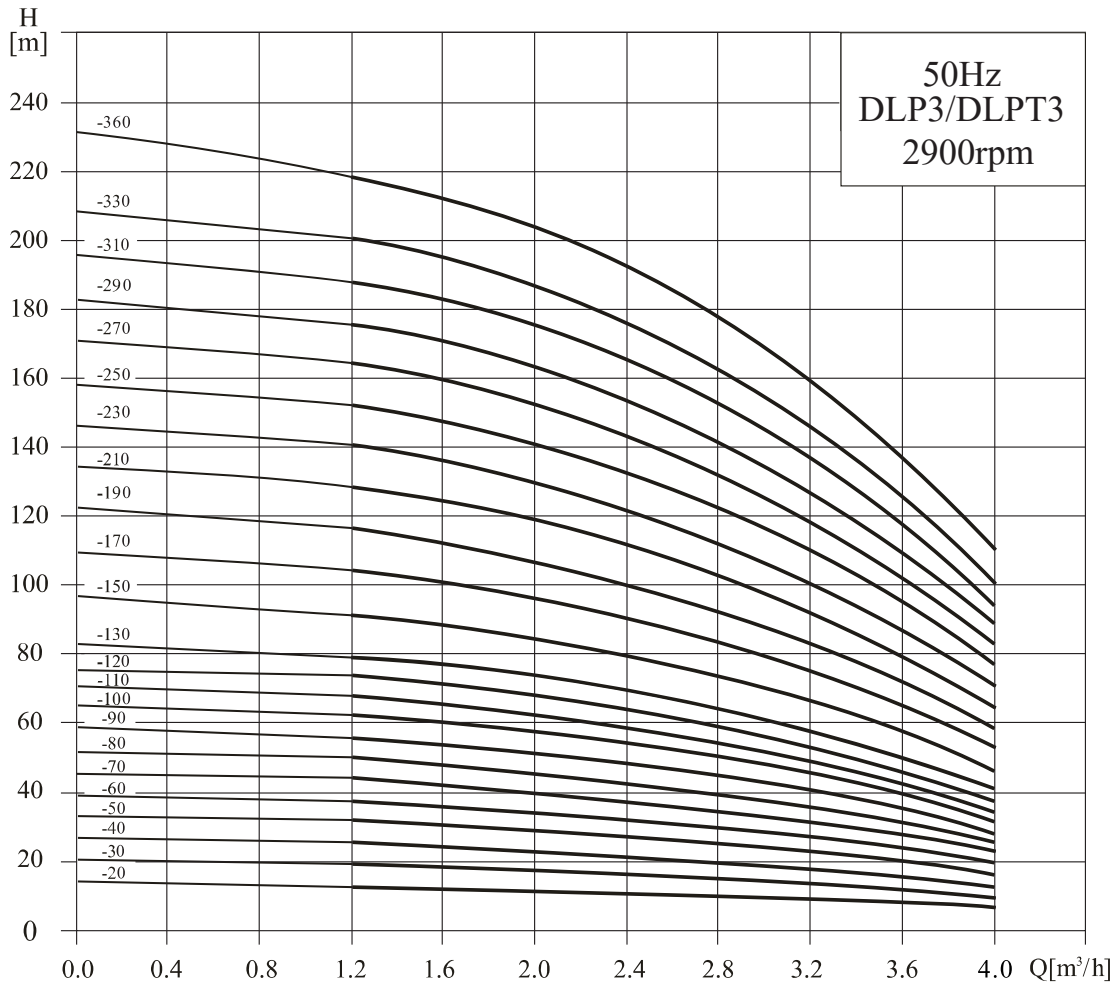

安装图

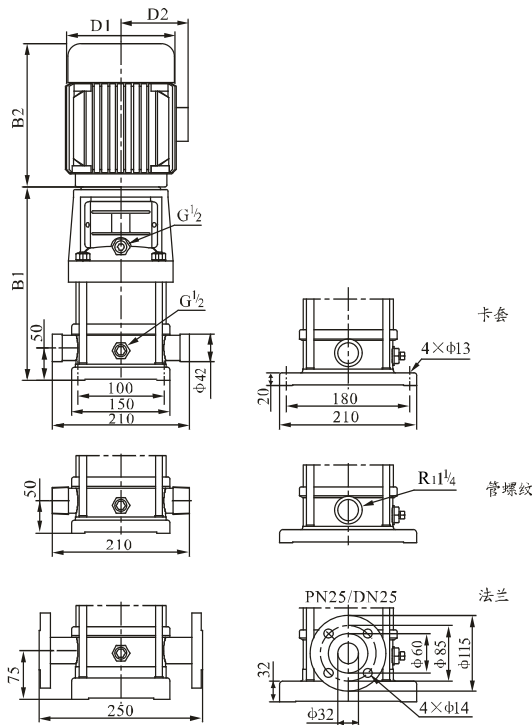

尺寸和重量

型号	尺寸(mm)					重量(kg)
	B1	B2	B1+B2	D1	D2	
DLP3-20	258	225	483	148	117	20
DLP3-30	276	225	501	148	117	20
DLP3-40	294	225	519	148	117	21
DLP3-50	312	225	537	148	117	21
DLP3-60	330	225	555	148	117	23
DLP3-70	348	225	573	148	117	24
DLP3-80	376	245	621	170	142	27
DLP3-90	394	245	639	170	142	28
DLP3-100	412	245	657	170	142	28
DLP3-110	430	245	675	170	142	29
DLP3-120	448	245	693	170	142	30
DLP3-130	466	245	711	170	142	31
DLP3-150	502	245	747	170	142	32
DLP3-170	548	290	838	190	155	38
DLP3-190	584	290	874	190	155	39
DLP3-210	620	290	910	190	155	42
DLP3-230	656	290	946	190	155	43
DLP3-250	692	290	982	190	155	44
DLP3-270	728	290	1018	190	155	45
DLP3-290	764	290	1054	190	155	46
DLP3-310	810	345	1155	197	165	54
DLP3-330	846	345	1191	197	165	55
DLP3-360	900	345	1245	197	165	57

性能表

型号	配用电机 (kW)	Q (m ³ /h)	H (m)									
			1.2	1.6	2.0	2.4	2.8	3.0	3.2	3.6	4.0	
DLP3-20	0.37	H (m)	12.5	11.5	11	10.5	10	9	8	7	6	
DLP3-30	0.37		19	18.5	17.5	16.5	15	14	13	11	9	
DLP3-40	0.37		25	24	23	21.5	20	19	18	15	12	
DLP3-50	0.37		31	30	29	27	25	23	22	19	16	
DLP3-60	0.55		36	35	34	32	30	28	27	23	19	
DLP3-70	0.55		43	41	39	37	34	32	31	27	22	
DLP3-80	0.75		49	47	45	43	39	37	35	31	25	
DLP3-90	0.75		55	53	51	48	45	42	40	35	28	
DLP3-100	0.75		61	59	57	54	50	47	45	39	31	
DLP3-110	1.1		67	64	61	58	54	51	49	42	34	
DLP3-120	1.1		73	70	67	63	58	55	52	45	37	
DLP3-130	1.1		78	76	73	69	64	60	57	49	40	
DLP3-150	1.1		90	88	84	79	73	69	66	57	46	
DLP3-170	1.5		103	100	96	90	83	79	75	64	52	
DLP3-190	1.5		115	112	107	100	92	88	83	72	58	
DLP3-210	2.2		128	124	119	112	102	98	91	79	64	
DLP3-230	2.2	140	135	130	122	112	107	100	86	70		
DLP3-250	2.2	151	147	141	131	122	116	109	94	76		
DLP3-270	2.2	164	159	152	143	132	124	117	101	82		
DLP3-290	2.2	175	170	163	153	142	133	126	109	88		
DLP3-310	3.0	187	182	175	165	153	142	135	116	94		
DLP3-330	3.0	199	194	187	176	163	151	145	125	100		
DLP3-360	3.0	218	212	204	192	178	168	159	137	109		

单相电机、隔爆电机外形尺寸有所变动，详情请咨询本公司。

性能曲线

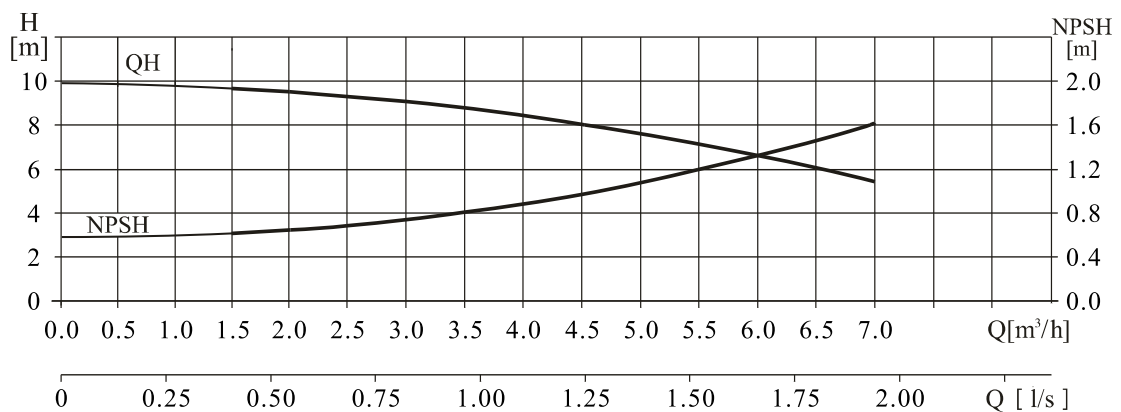
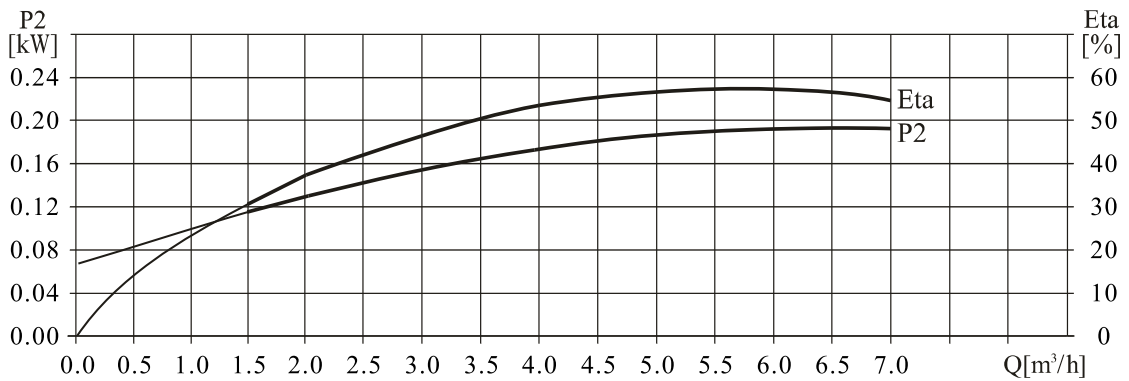
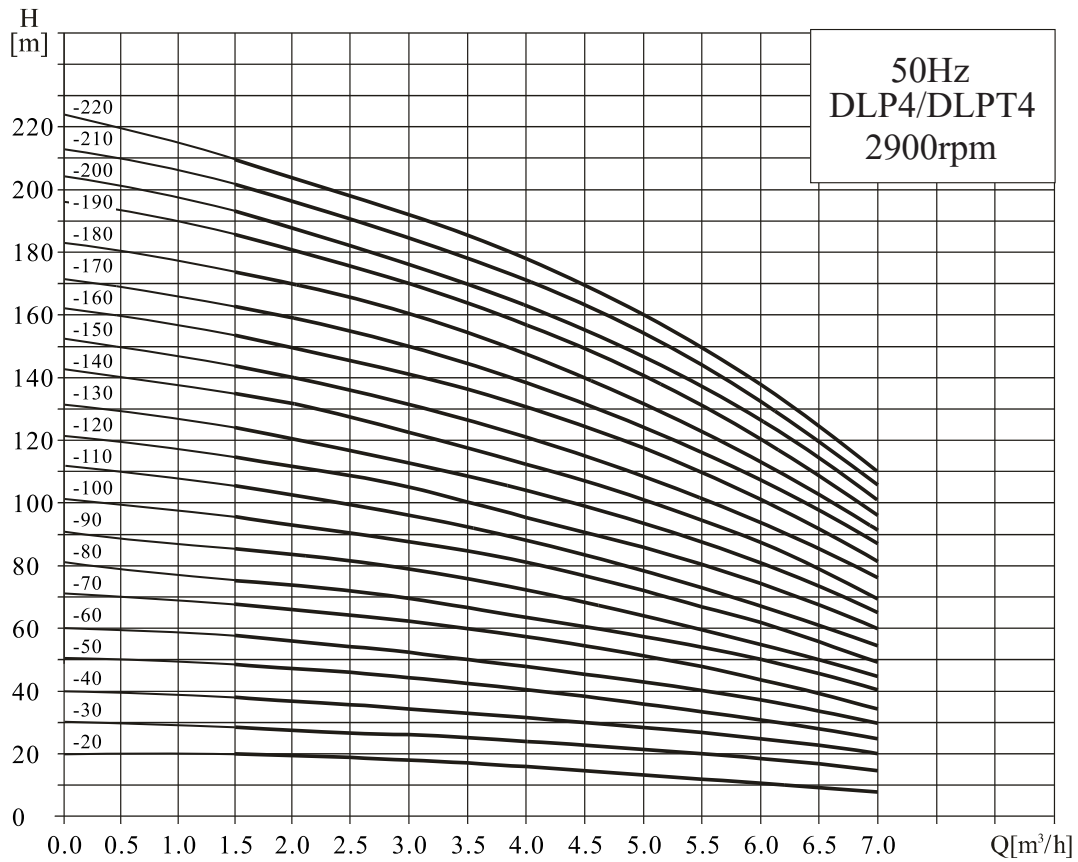

安装图

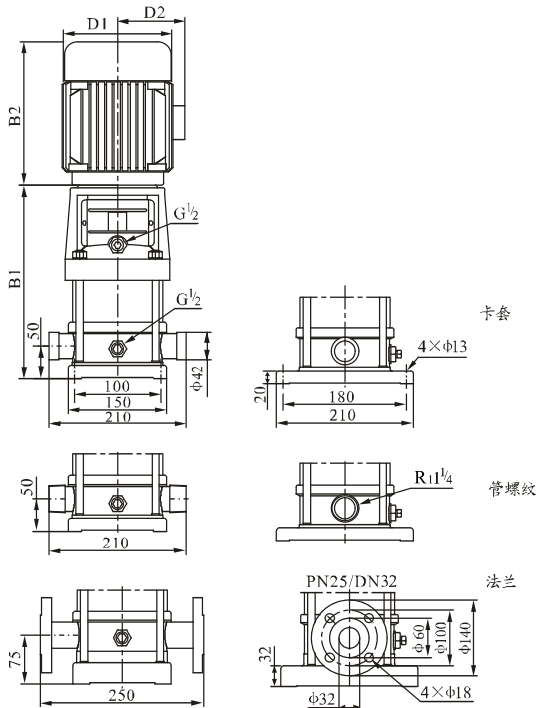

尺寸和重量

型号	尺寸(mm)					重量(kg)
	B1	B2	B1+B2	D1	D2	
DLP4-20	276	225	501	148	117	21
DLP4-30	303	225	528	148	117	22
DLP4-40	340	245	585	170	142	25
DLP4-50	367	245	612	170	142	27
DLP4-60	394	245	639	170	142	27
DLP4-70	431	290	721	190	155	33
DLP4-80	458	290	748	190	155	33
DLP4-100	512	290	802	190	155	37
DLP4-120	566	290	856	190	155	38
DLP4-140	630	345	975	197	165	46
DLP4-160	684	345	1029	197	165	48
DLP4-190	765	355	1120	230	188	57
DLP4-220	846	355	1201	230	188	59

性能表

型号	配用电机 (kW)	Q (m ³ /h)	1.5	2.0	3.0	4.0	5.0	6.0	7.0
DLP4-20	0.37	H (m)	19	18	17	15	13	10	8
DLP4-30	0.55		28	27	26	24	20	18	13
DLP4-40	0.75		38	36	34	32	27	24	19
DLP4-50	1.1		47	45	43	40	34	31	23
DLP4-60	1.1		56	54	52	48	41	37	28
DLP4-70	1.5		66	63	61	56	48	43	33
DLP4-80	1.5		74	72	70	64	55	50	38
DLP4-100	2.2		96	90	87	81	71	62	48
DLP4-120	2.2		114	108	104	95	85	75	58
DLP4-140	3.0		136	126	122	112	101	89	68
DLP4-160	3.0		152	144	140	129	115	101	78
DLP4-190	4.0		183	171	168	153	137	122	93
DLP4-220	4.0		211	200	192	178	160	138	108

单相电机、隔爆电机外形尺寸有所变动，详情请咨询本公司。

性能曲线

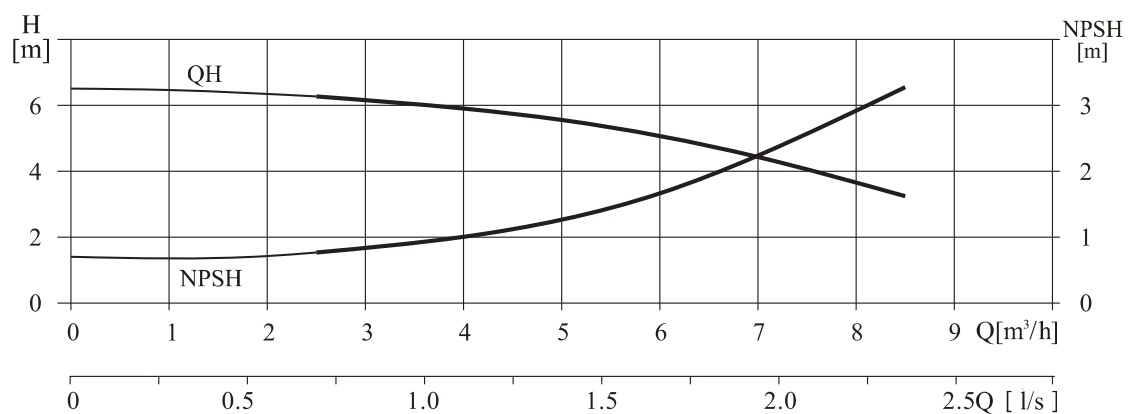
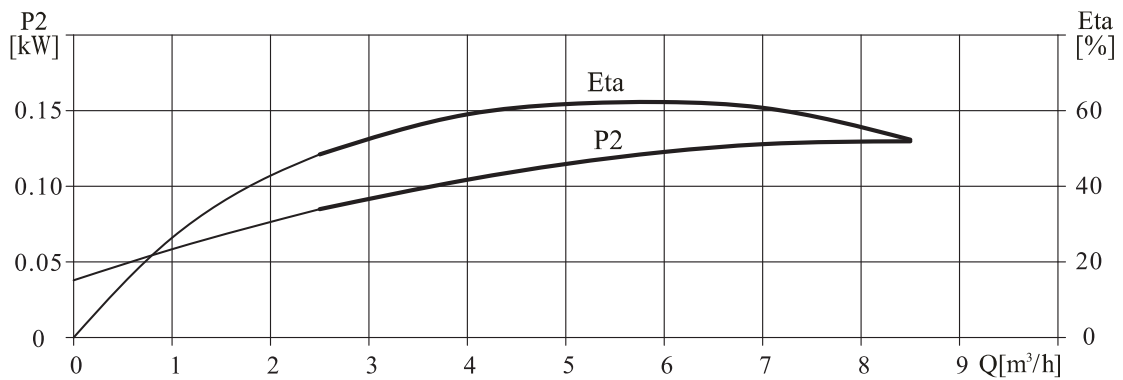
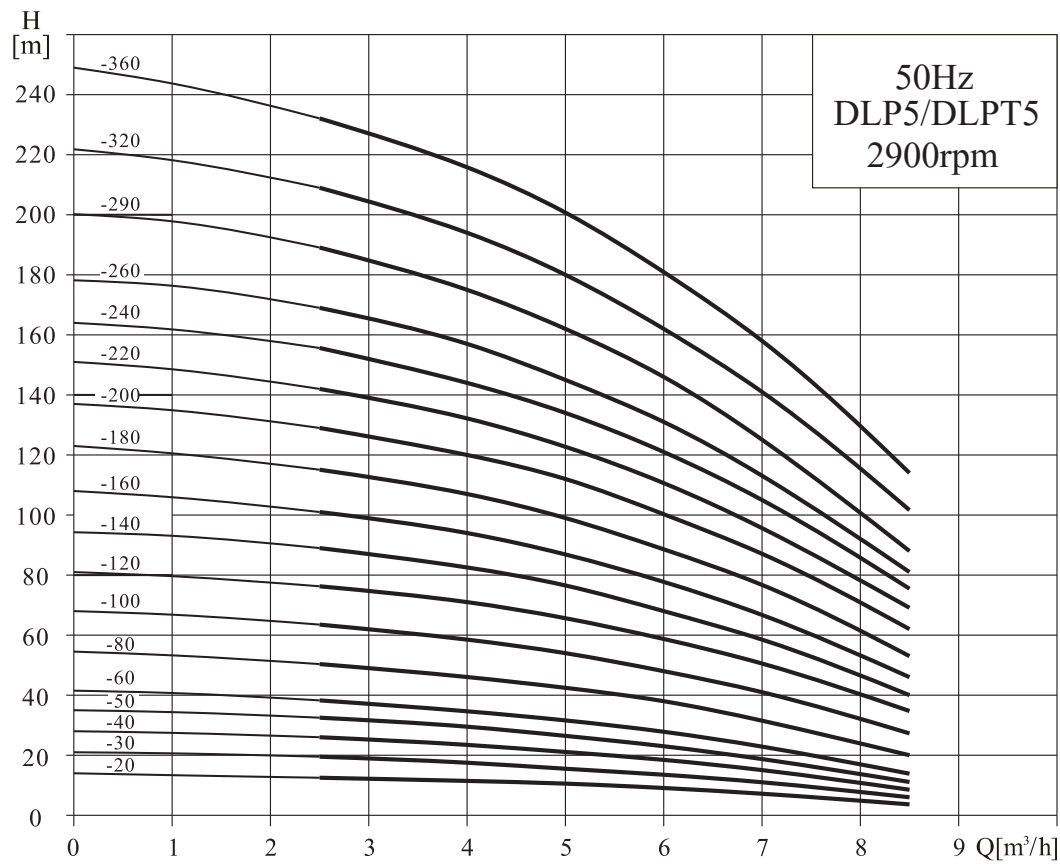

安装图

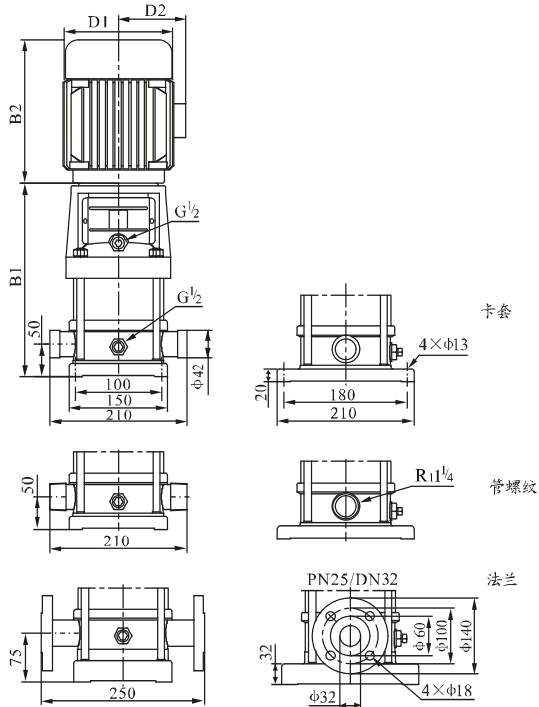

尺寸和重量

型号	尺寸(mm)					重量(kg)
	B1	B2	B1+B2	D1	D2	
DLP5-20	276	225	501	148	117	21
DLP5-30	303	225	528	148	117	22
DLP5-40	330	225	555	148	117	23
DLP5-50	367	245	612	170	142	25
DLP5-60	394	245	639	170	142	26
DLP5-80	448	245	693	170	142	27
DLP5-100	512	290	802	190	155	33
DLP5-120	566	290	856	190	155	37
DLP5-140	620	290	910	190	155	38
DLP5-160	674	290	964	190	155	39
DLP5-180	738	345	1083	197	165	48
DLP5-200	792	345	1137	197	165	49
DLP5-220	846	355	1201	230	185	57
DLP5-240	900	355	1255	230	185	58
DLP5-260	954	355	1309	230	185	59
DLP5-290	1035	355	1390	230	185	60
DLP5-320	1136	390	1526	260	210	75
DLP5-360	1244	390	1634	260	210	76

性能表

型号	配用电机 (kW)	Q (m ³ /h)	2.5	4	5	6	7	8.5
			H (m)					
DLP5-20	0.37	H (m)	12.5	11.5	10.5	9	7	3.5
DLP5-30	0.55		19.5	17.5	15.5	13.5	11	6
DLP5-40	0.55		26	23.5	21	18.5	15	8.5
DLP5-50	0.75		32.5	29.5	26.5	23	18.5	11
DLP5-60	1.1		38.5	34.5	31.5	28	23	14
DLP5-80	1.1		50.5	46	42.5	38	31.5	20
DLP5-100	1.5		63.5	58.5	54	48	41	27.5
DLP5-120	2.2		76	71	65.5	58.5	50.5	35
DLP5-140	2.2		89	82	76.5	68	58.5	40
DLP5-160	2.2		101	94	87	77.5	66.5	46
DLP5-180	3.0		115	107	99	88.5	77	53
DLP5-200	3.0		129	120	112	100	87	62
DLP5-220	4.0		142	132	123	111	96	69
DLP5-240	4.0		156	144	134	121	105	75.5
DLP5-260	4.0		169	157	145	131	113	81
DLP5-290	4.0		189	175	162	146	125	88
DLP5-320	5.5		209	194	180	162	141	102
DLP5-360	5.5		232	216	201	181	158	114

单相电机、隔爆电机外形尺寸有所变动，详情请咨询本公司。

性能曲线

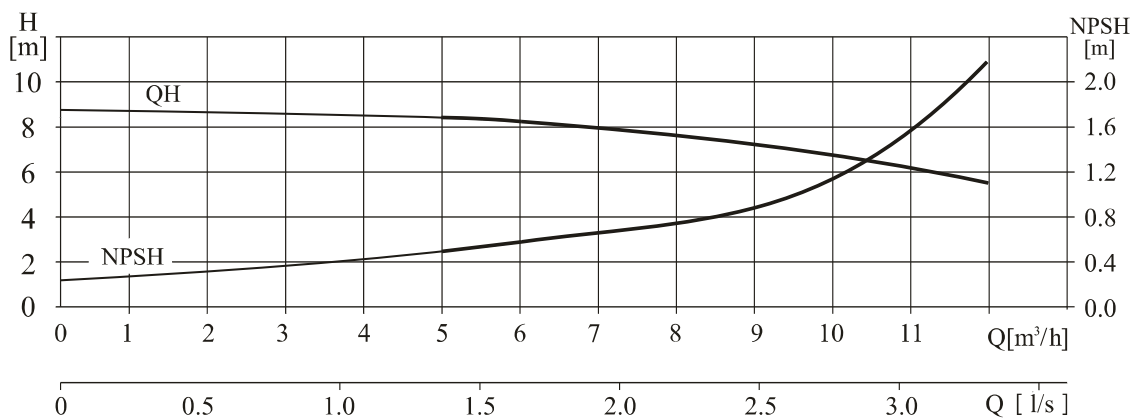
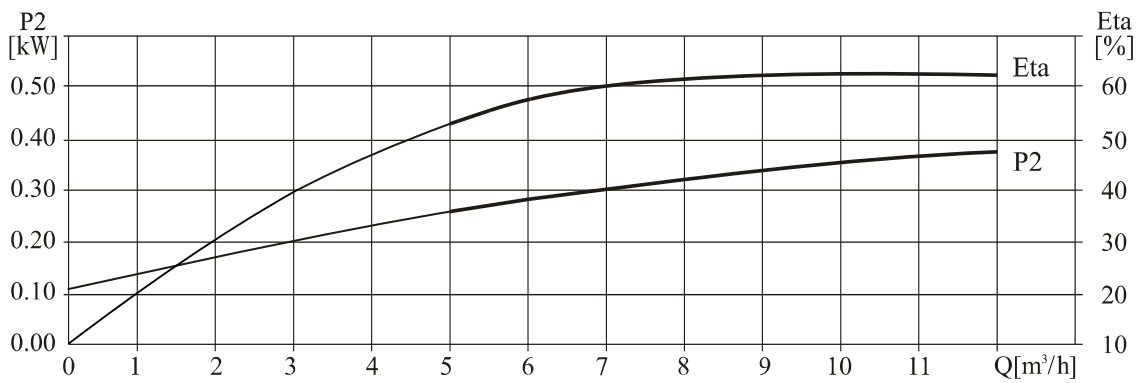
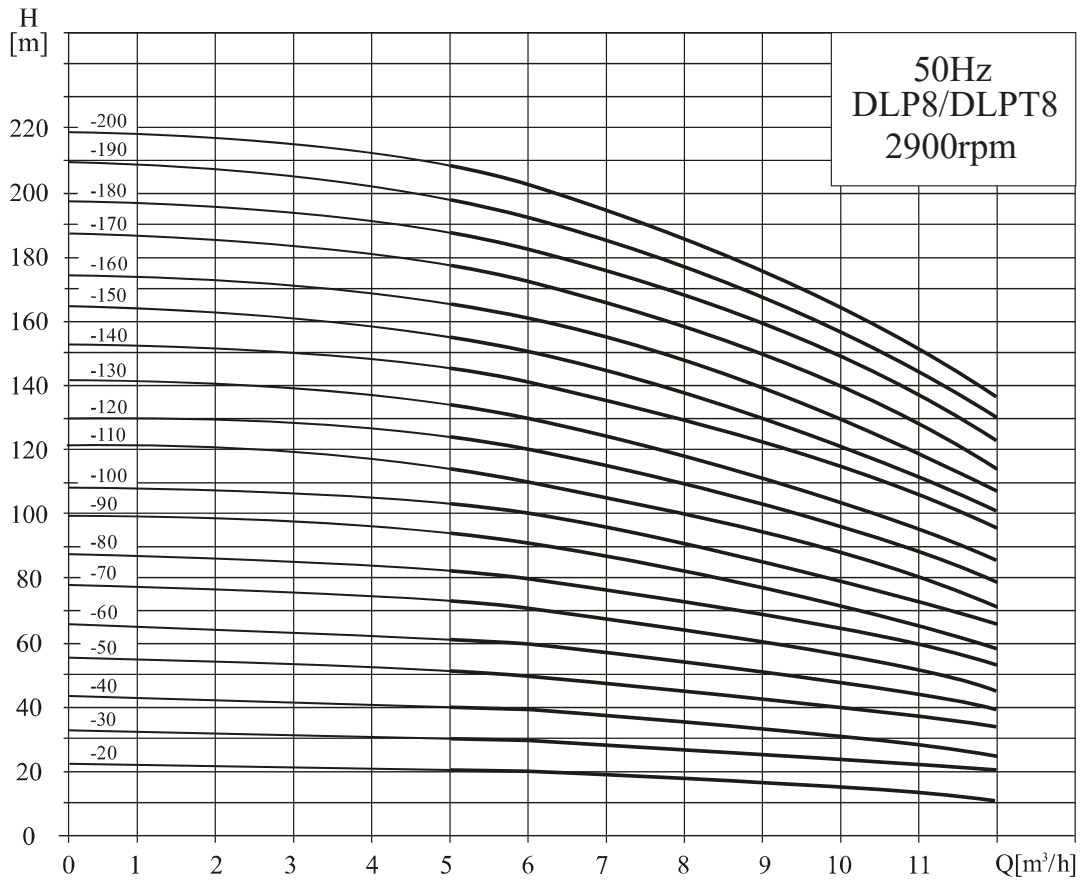

安装图

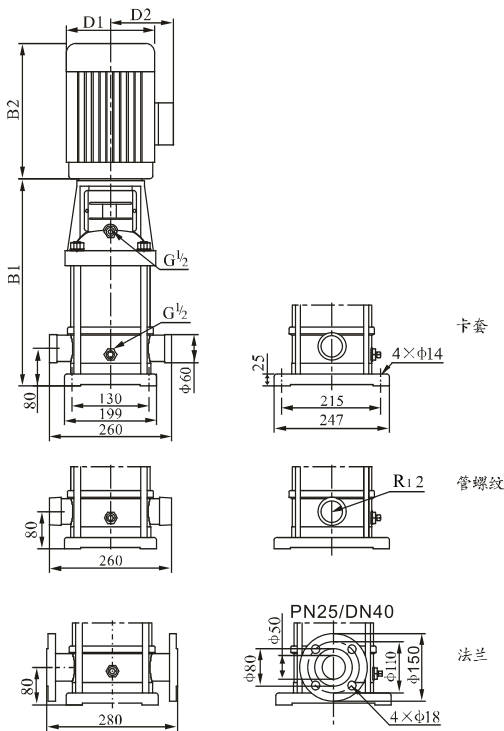

尺寸和重量

型号	尺寸(mm)					重量(kg)
	B1	B2	B1+B2	D1	D2	
DLP8-20	347	245	592	170	142	32
DLP8-30	377	245	622	170	142	34
DLP8-40	417	290	707	190	155	40
DLP8-50	447	290	737	190	155	44
DLP8-60	477	290	767	190	155	45
DLP8-80	547	345	892	197	165	53
DLP8-100	607	355	962	230	188	64
DLP8-120	667	355	1022	230	188	66
DLP8-140	747	390	1137	260	208	81
DLP8-160	807	390	1197	260	208	84
DLP8-180	867	390	1257	260	208	93
DLP8-200	927	390	1317	260	208	94

性能表

型号	配用电机 (kW)	Q (m ³ /h)	5	6	7	8	9	10	11	12
DLP8-20	0.75	H (m)	20	19.5	19	18	17	16	14	13
DLP8-30	1.1		30	29.5	28.5	27	25	24	21	19
DLP8-40	1.5		41	39.5	38	36	34	32	28	26
DLP8-50	2.2		52	50	48	45	42	40	36	32
DLP8-60	2.2		62	60	57	54	51	48	43	39
DLP8-80	3.0		83	80	77	73	69	65	58	52
DLP8-100	4.0		104	100	97	92	87	81	73	65
DLP8-120	4.0		124	120	116	111	104	92	87	78
DLP8-140	5.5		145	141	136	130	122	113	102	92
DLP8-160	5.5		166	161	156	148	139	130	118	106
DLP8-180	7.5		187	182	175	167	157	146	134	120
DLP8-200	7.5		208	202	195	186	175	163	150	135

单相电机、隔爆电机外形尺寸有所变动，详情请咨询本公司。

性能曲线

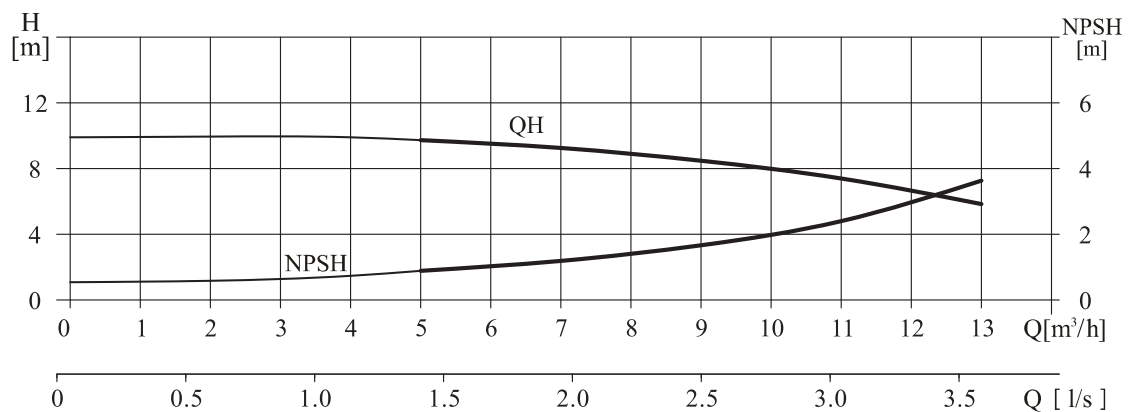
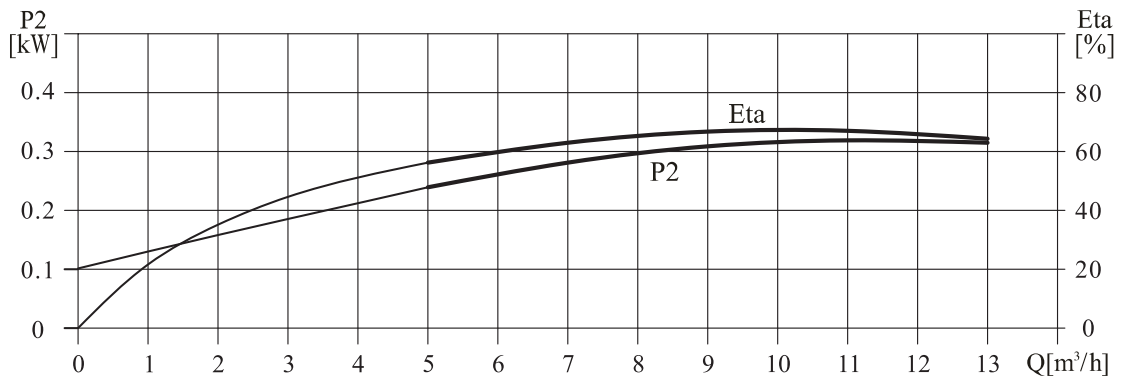
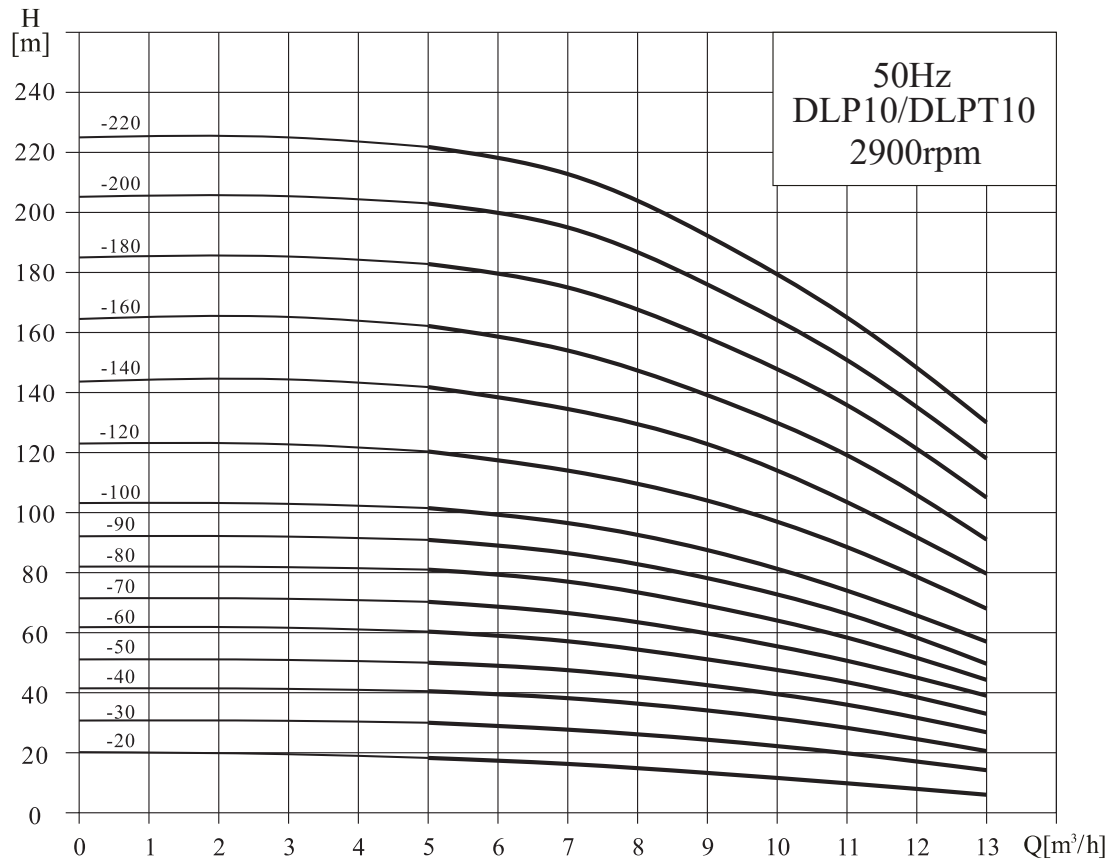

安装图

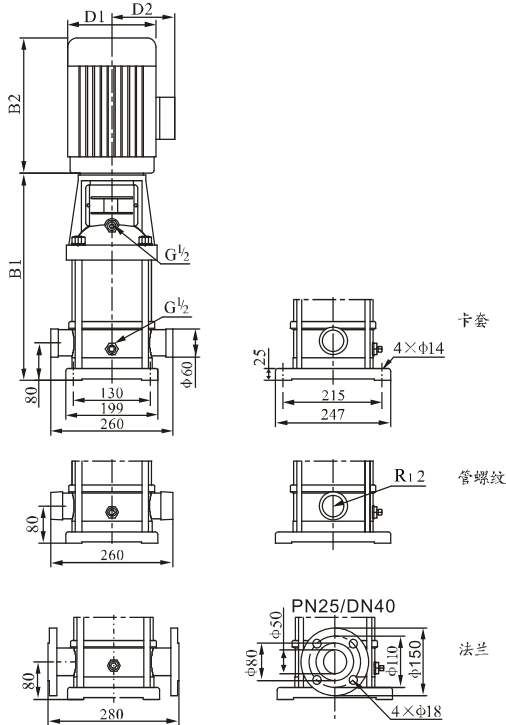

尺寸和重量

型号	尺寸(mm)					重量(kg)
	B1	B2	B1+B2	D1	D2	
DLP10-20	347	245	592	170	142	32
DLP10-30	377	245	722	170	142	34
DLP10-40	417	290	707	190	155	40
DLP10-50	447	290	737	190	155	44
DLP10-60	477	290	767	190	155	45
DLP10-70	517	345	862	197	165	52
DLP10-80	547	345	892	197	165	53
DLP10-90	577	345	922	197	165	54
DLP10-100	607	355	962	230	185	64
DLP10-120	667	355	1022	230	185	66
DLP10-140	747	390	1137	260	210	81
DLP10-160	807	390	1197	260	210	82
DLP10-180	867	390	1257	260	210	93
DLP10-200	927	390	1317	260	210	94
DLP10-220	987	390	1377	260	210	95

性能表

型号	配用电机 (kW)	Q (m ³ /h)	H (m)									
			5	6	7	8	9	10	11	12	13	
DLP10-20	0.75	H (m)	18.5	17	16	14	13	12	10	8.5	7	
DLP10-30	1.1		30	28.5	27.5	25.5	24.5	22	20	18	14.5	
DLP10-40	1.5		40.5	39.5	38.5	36.5	34	31.5	28.5	25.5	21	
DLP10-50	2.2		50	49	47.5	45.5	42.5	39.5	36	32	27	
DLP10-60	2.2		60	59	57	55	51	47.5	43.5	39	33.5	
DLP10-70	3.0		70.5	69	66.5	64	59.5	55.5	50.5	45.5	39	
DLP10-80	3.0		81	79	77	74.5	69	64	58.5	53	44.5	
DLP10-90	3.0		91	89	86.5	82.5	78	72	66.5	59.5	50	
DLP10-100	4.0		101.5	99	96.5	92.5	87.5	81.5	74	67	57	
DLP10-120	4.0		120.5	119	114	110	104	97	88.5	80	68	
DLP10-140	5.5		142	139	134.5	131	123	114	103.5	93.5	80	
DLP10-160	5.5		162	159	154	148.5	139	130	119	107	91	
DLP10-180	7.5		183	180	175	167	158	148	136	121	105	
DLP10-200	7.5		203	200	195	186	176	165	151	134	118	
DLP10-220	7.5		222	219	213	203	192	179	165	149	130	

单相电机、隔爆电机外形尺寸有所变动，详情请咨询本公司。

性能曲线

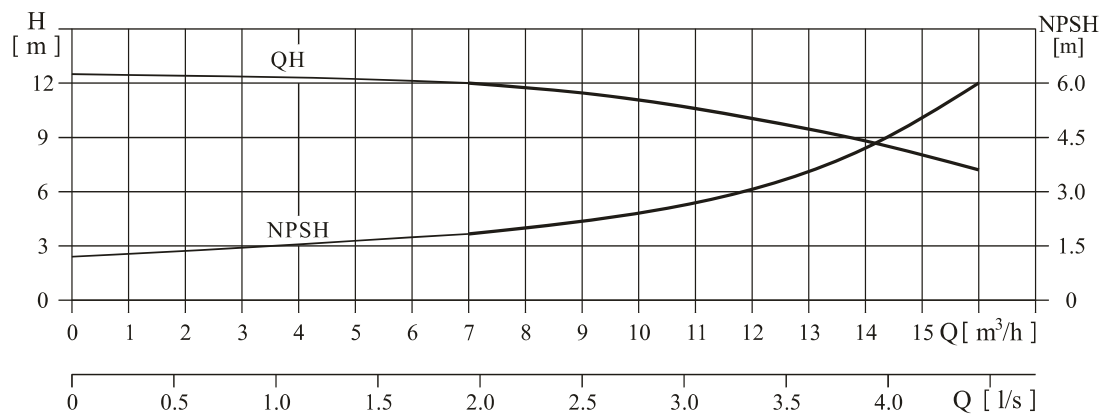
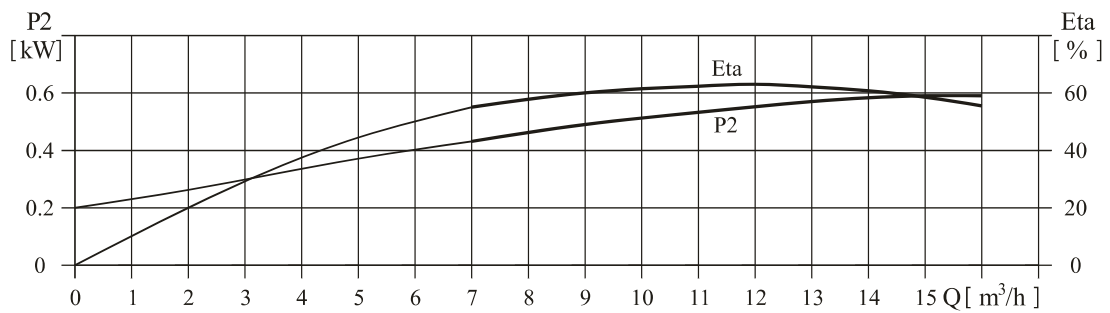
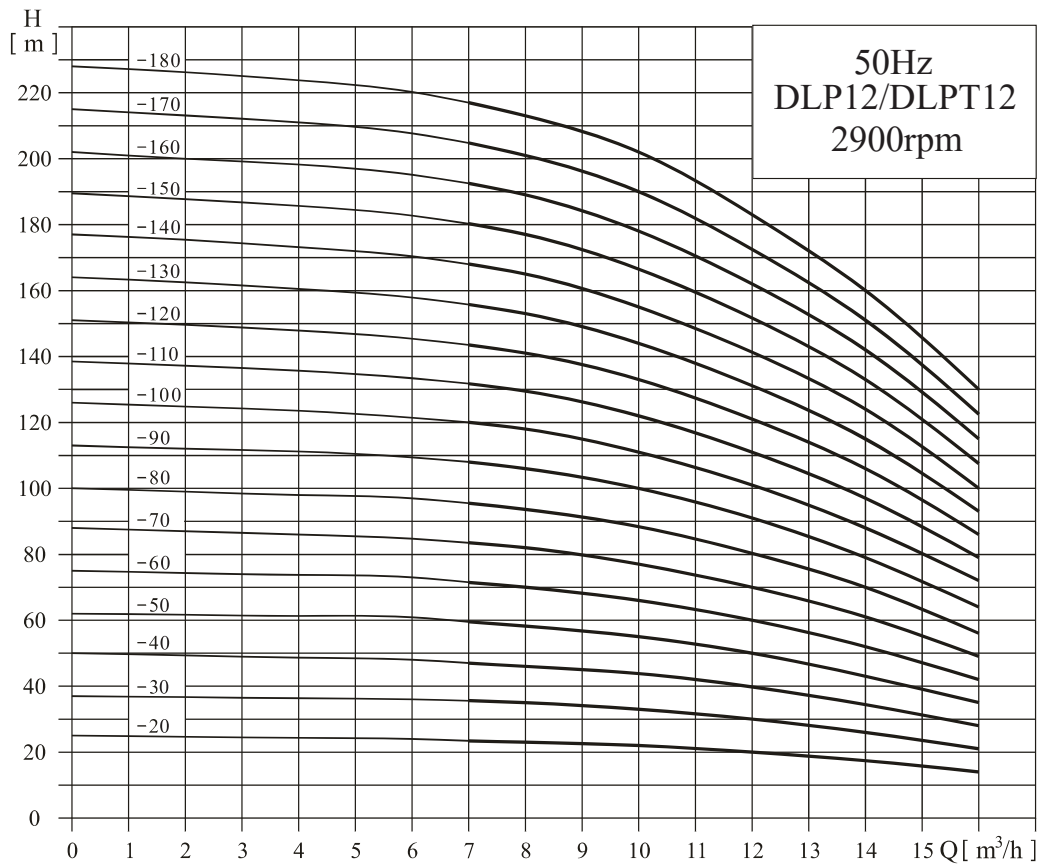

安装图

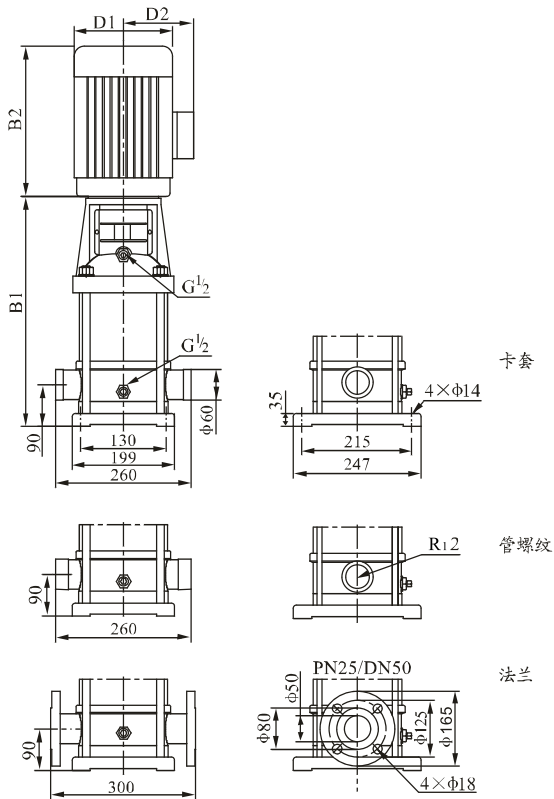

尺寸和重量

型号	尺寸(mm)					重量(kg)
	B1	B2	B1+B2	D1	D2	
DLP12-20	367	290	657	190	155	39
DLP12-30	397	290	687	190	155	43
DLP12-40	437	345	782	197	165	51
DLP12-50	467	345	812	197	165	53
DLP12-60	497	355	852	230	188	61
DLP12-70	547	390	937	260	208	73
DLP12-80	577	390	967	260	208	74
DLP12-90	607	390	997	260	208	76
DLP12-100	637	390	1027	260	208	83
DLP12-120	697	390	1087	260	208	87
DLP12-140	757	390	1147	260	208	108
DLP12-160	905	500	1405	330	255	161
DLP12-180	965	500	1465	330	255	164

性能表

型号	配用电机 (kW)	Q (m ³ /h)	H (m)											
			7	8	9	10	11	12	13	14	15	16		
DLP12-20	1.5	H (m)	23.5	23	22.5	22	21	20	18.5	17	15.5	14		
DLP12-30	2.2		35.5	35	34	33	31.5	30	28	26	23.5	21		
DLP12-40	3		47	46	45	44	42	40	37	34	31	28		
DLP12-50	3		59.5	58	56.5	55	52.5	50	46.5	43	39	35		
DLP12-60	4		71.5	70	68	66	63	60	56	52	47	42		
DLP12-70	5.5		83.5	82	79.5	77	73.5	70	65.5	61	55	49		
DLP12-80	5.5		95.5	94	91	88	84	80	75	70	63	56		
DLP12-90	5.5		108	106	103	100	95.5	91	85	79	71.5	64		
DLP12-100	7.5		120	118	114.5	111	106	101	94.5	88	80	72		
DLP12-120	7.5		143.5	141	137	133	127	121	113.5	106	96	86		
DLP12-140	9.2		168	165	160	155	148	141	132.5	124	112	100		
DLP12-160	11		192.5	189	183.5	178	170	162	152	142	128.5	115		
DLP12-180	11		217	213	207.5	202	192.5	183	171.5	160	145	130		

单相电机、隔爆电机外形尺寸有所变动，详情请咨询本公司。

性能曲线

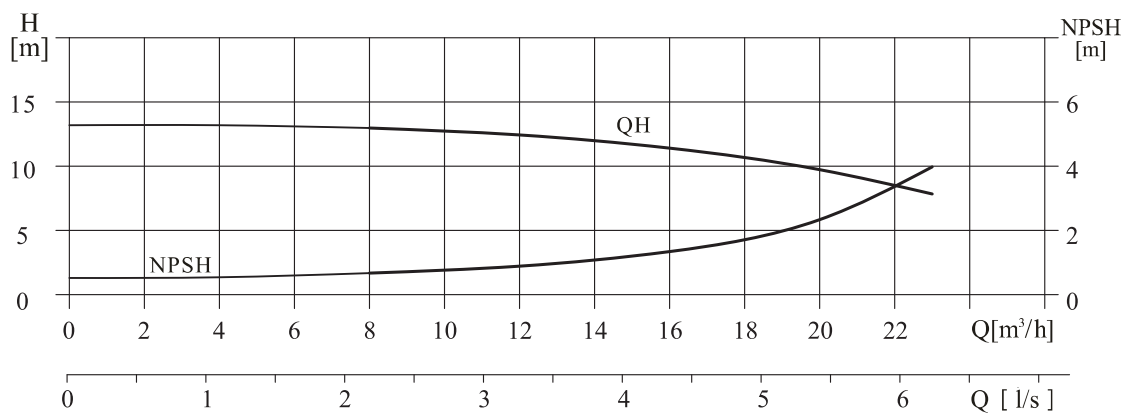
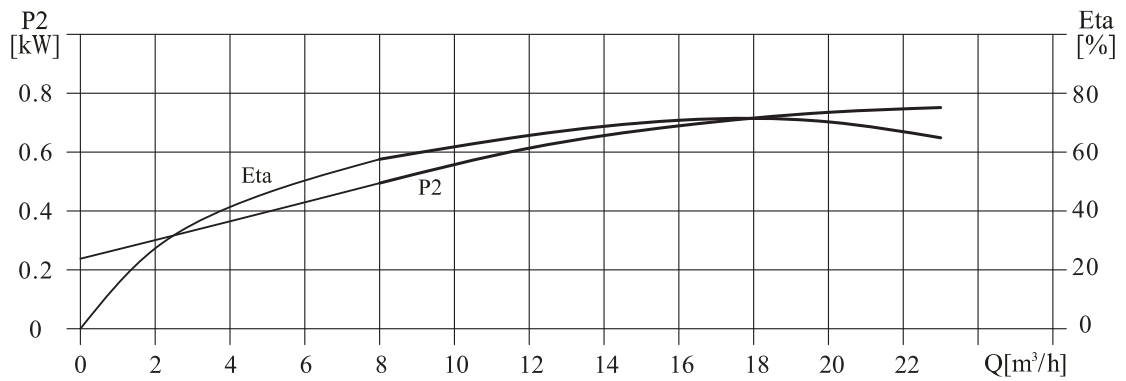
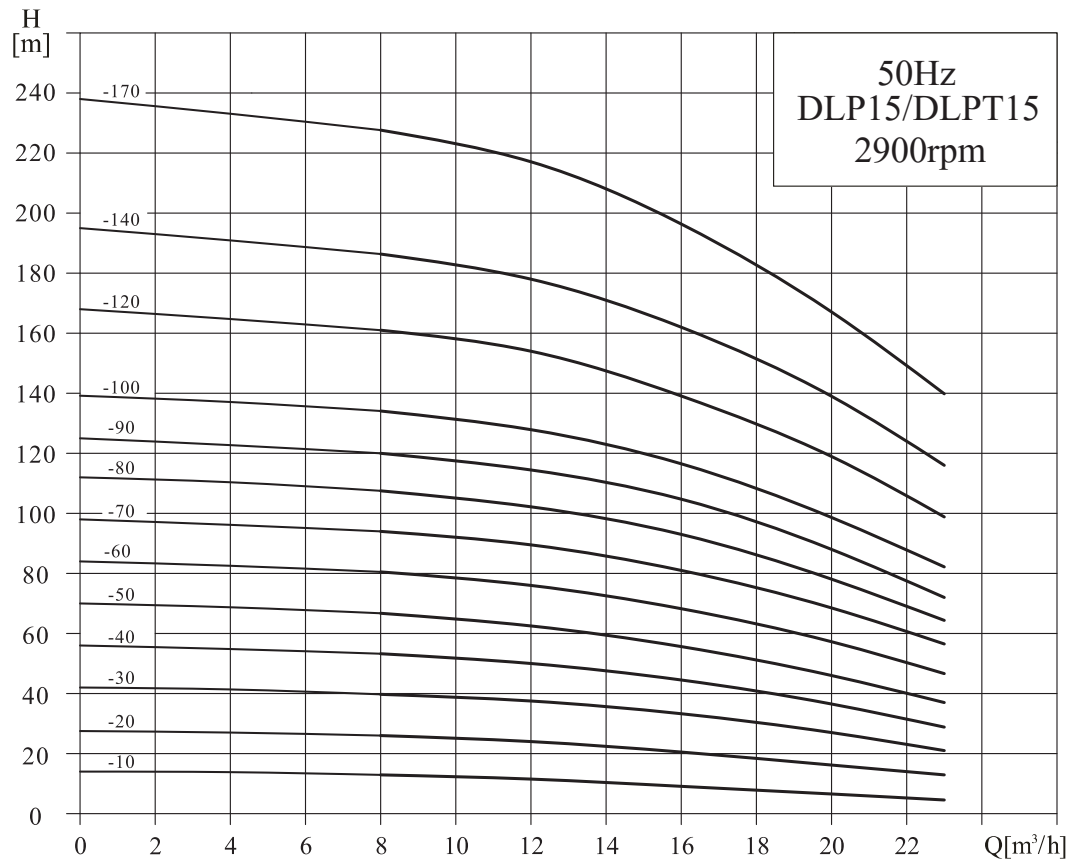

安装图

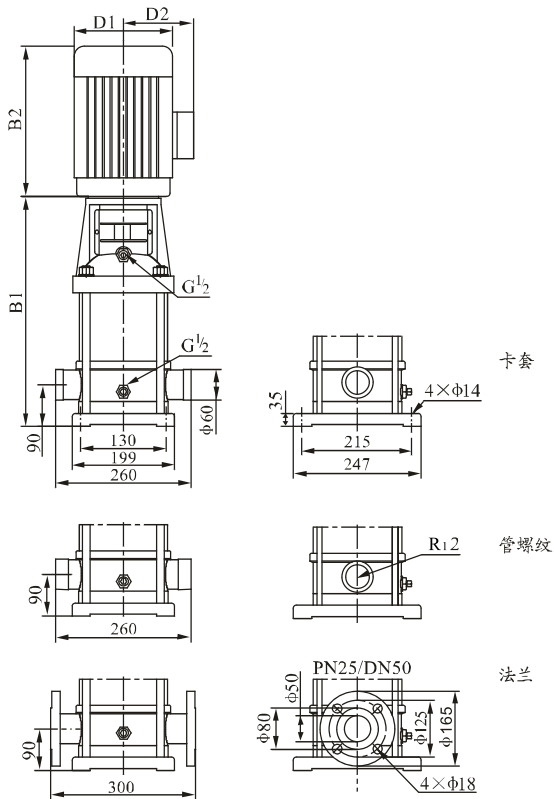

尺寸和重量

型号	尺寸(mm)					重量(kg)
	B1	B2	B1+B2	D1	D2	
DLP15-10	352	245	597	170	142	33
DLP15-20	397	290	687	190	155	42
DLP15-30	452	345	797	197	165	50
DLP15-40	497	355	852	230	185	59
DLP15-50	542	355	897	230	185	60
DLP15-60	607	390	997	260	210	77
DLP15-70	652	390	1042	260	210	78
DLP15-80	697	390	1087	260	210	86
DLP15-90	742	390	1132	260	210	87
DLP15-100	875	500	1375	330	255	160
DLP15-120	965	500	1465	330	255	161
DLP15-140	1055	500	1555	330	255	162
DLP15-170	1190	500	1690	330	255	179

性能表

型号	配用电机 (kW)	Q (m ³ /h)	8	10	12	14	15	16	18	20	23
DLP15-10	1.1	H (m)	13	12	11.5	10.5	10	9	7.5	6	4.5
DLP15-20	2.2		26	25	24	23	22	20.5	18	16	13
DLP15-30	3.0		39.5	38.5	37.5	35.5	34.5	33.5	30.5	27	21
DLP15-40	4.0		53	51.5	50	47.5	46	44.5	41	36.5	29
DLP15-50	4.0		67	64.5	62.5	60	58	55.5	52	46	37
DLP15-60	5.5		80.5	78	76	73	70.5	68	63.5	57	46.5
DLP15-70	5.5		94	92	89.5	86	83.5	81	75.5	68.5	56.5
DLP15-80	7.5		107.5	106	102.5	98.5	96	93	86.5	78	64.5
DLP15-90	7.5		120	118	114.5	110	107	105	97	88	72
DLP15-100	11		134	132	128	123	120	116.5	108.5	98.5	82.5
DLP15-120	11		161	158	154	148	144	139	130	119	99
DLP15-140	11		186	183	178	172	167	162	152	139	116
DLP15-170	15		227	224	217	210	203	196	185	167	140

单相电机、隔爆电机外形尺寸有所变动，详情请咨询本公司。

性能曲线

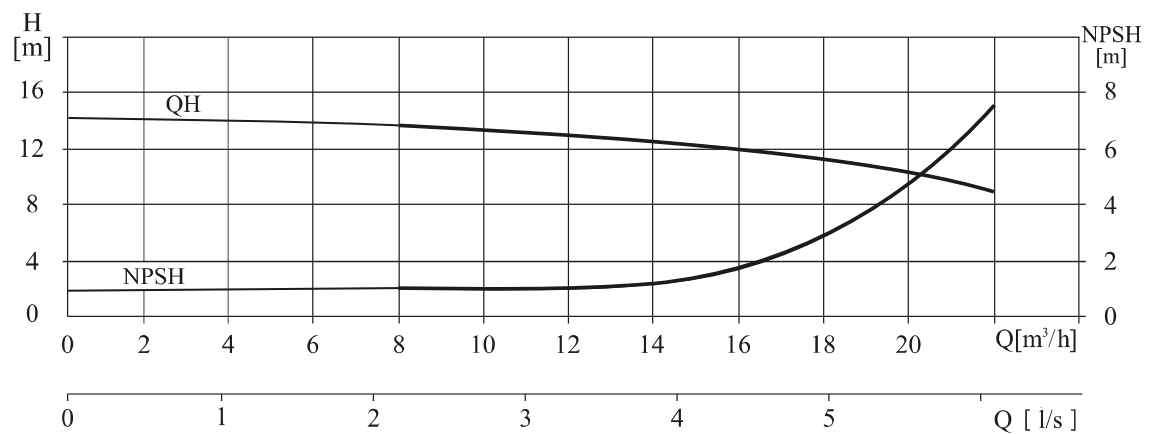
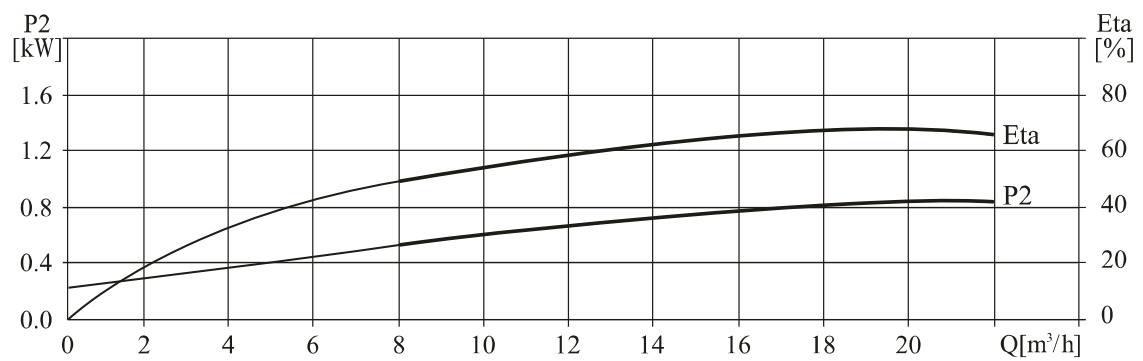
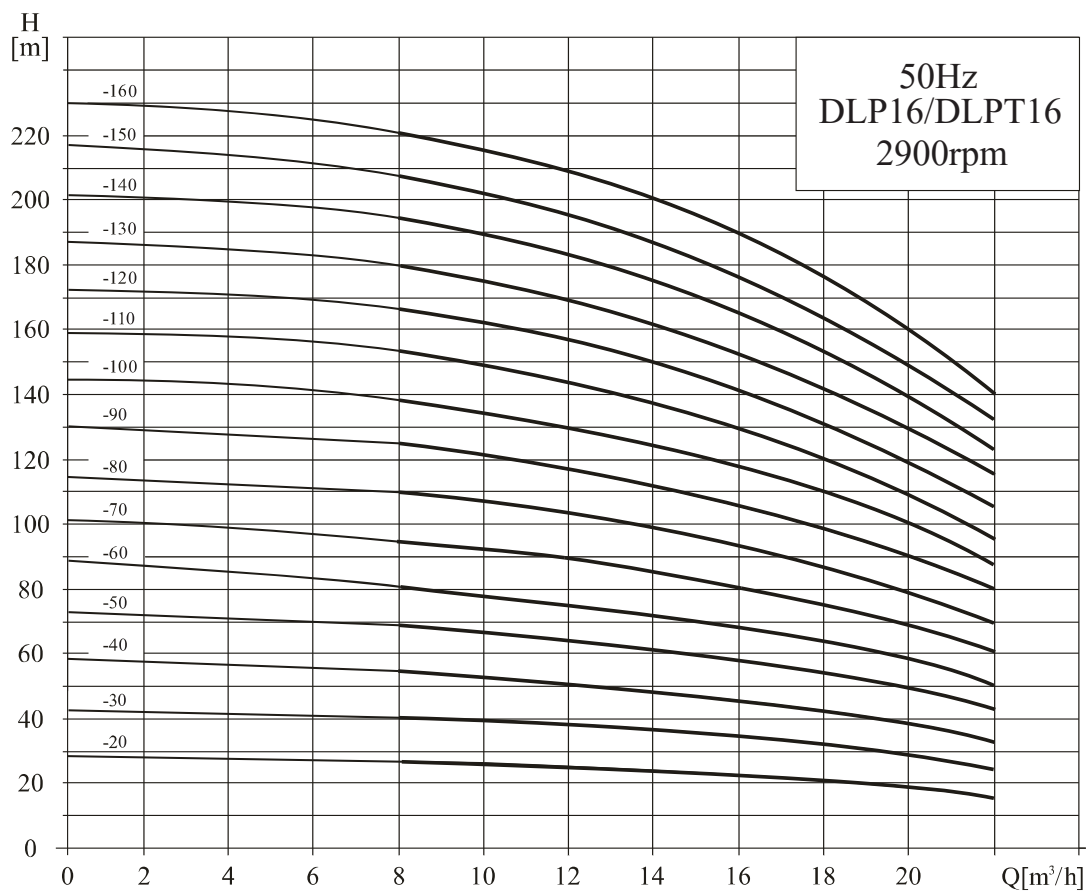

安装图

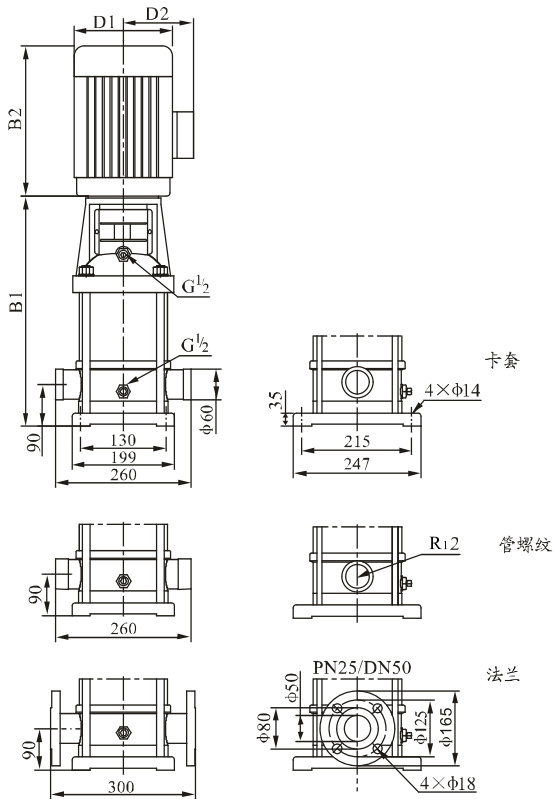

尺寸和重量

型号	尺寸(mm)					重量(kg)
	B1	B2	B1+B2	D1	D2	
DLP16-20	397	290	687	190	155	42
DLP16-30	452	345	797	197	165	50
DLP16-40	497	355	852	230	188	59
DLP16-50	562	390	952	260	208	76
DLP16-60	607	390	997	260	208	77
DLP16-70	652	390	1042	260	208	84
DLP16-80	697	390	1087	260	208	86
DLP16-100	787	390	1177	260	208	106
DLP16-120	965	500	1465	330	255	161
DLP16-140	1055	500	1555	330	255	174
DLP16-160	1145	500	1645	330	255	178

性能表

型号	配用电机 (kW)	Q (m ³ /h)	8	10	12	14	16	18	20	22
DLP16-20	2.2	H (m)	27	26	25	24	22	21	19	16
DLP16-30	3.0		41	40	38	37	34	32	29	25
DLP16-40	4.0		54	53	52	49	46	43	38	34
DLP16-50	5.5		68	67	65	62	58	54	48	43
DLP16-60	5.5		82	80	78	74	70	64	58	52
DLP16-70	7.5		96	95	91	87	82	76	68	61
DLP16-80	7.5		110	108	104	99	94	86	77	70
DLP16-100	9.2		138	136	131	125	118	109	97	87
DLP16-120	11		166	162	157	150	141	130	116	105
DLP16-140	15		194	190	184	175	166	152	136	122
DLP16-160	15		222	217	210	200	189	174	156	140

单相电机、隔爆电机外形尺寸有所变动，详情请咨询本公司。

性能曲线

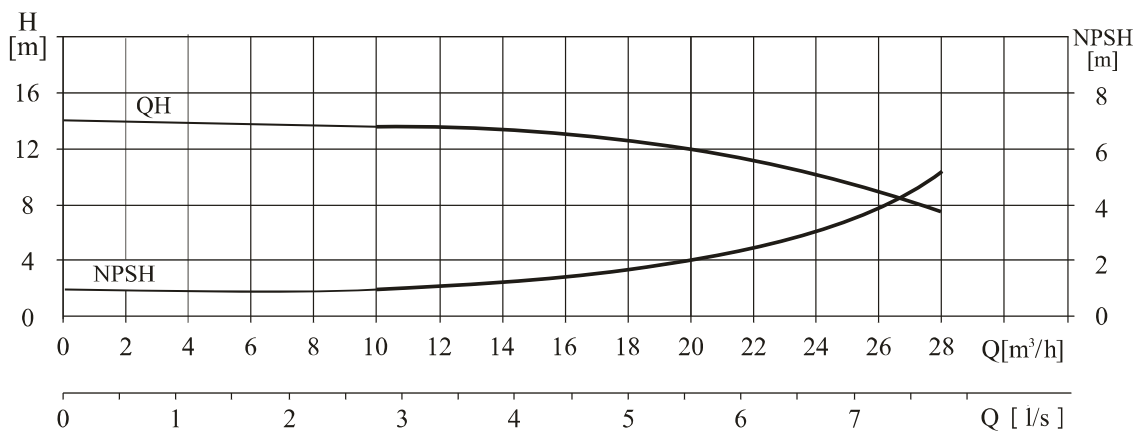
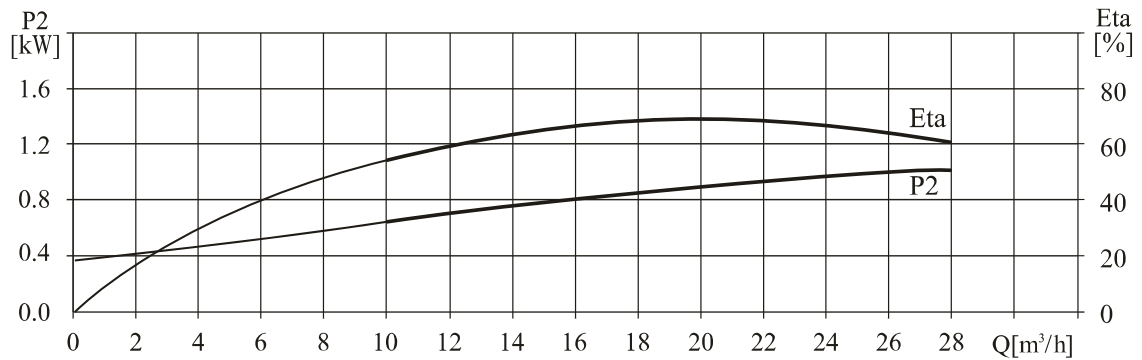
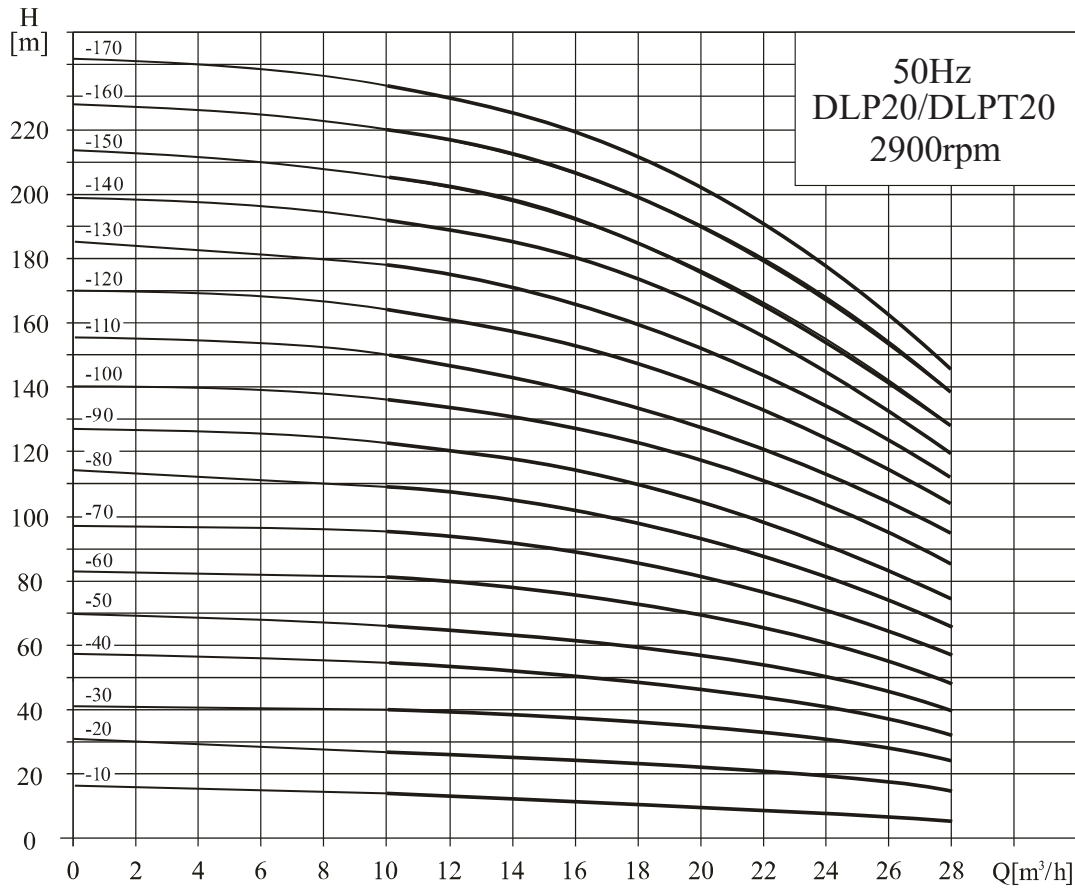

安装图

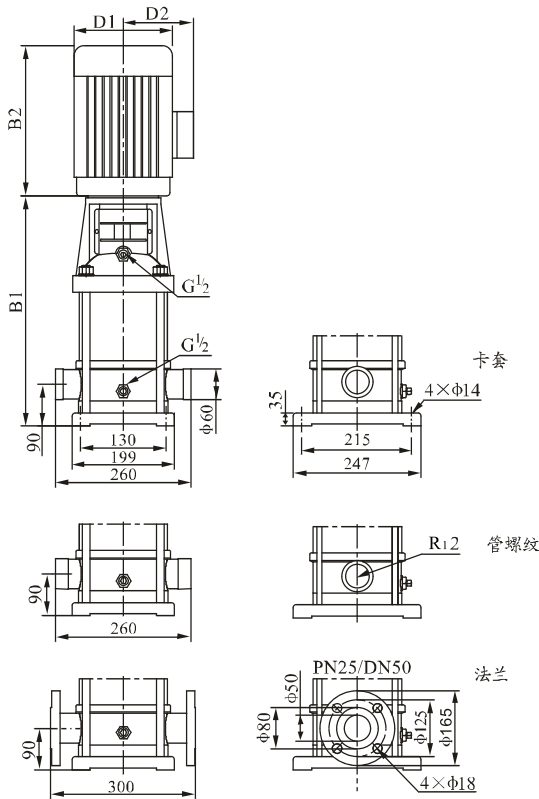

尺寸和重量

型号	尺寸(mm)					重量(kg)
	B1	B2	B1+B2	D1	D2	
DLP20-10	387	245	632	170	142	33
DLP20-20	397	290	687	190	155	42
DLP20-30	452	355	807	230	188	58
DLP20-40	517	390	907	260	208	74
DLP20-50	562	390	952	260	208	76
DLP20-60	607	390	997	260	208	82
DLP20-70	652	390	1042	260	208	84
DLP20-80	697	390	1087	260	208	101
DLP20-100	875	500	1375	330	255	157
DLP20-120	965	500	1465	330	255	170
DLP20-140	1055	500	1555	330	255	172
DLP20-170	1190	550	1740	330	255	195

性能表

型号	配用电机 (kW)	Q (m ³ /h)	10	12	14	16	18	20	22	24	26	28
			H (m)									
DLP20-10	1.1	H (m)	13.5	13	12.5	12	11	10	9	8	7	6
DLP20-20	2.2		27	26.5	26	25	24	23	22	20	18	15
DLP20-30	4.0		40	39.5	39	38	37	35	33	30	27	24
DLP20-40	5.5		54	53	52	51	49	47	44	41	37	33
DLP20-50	5.5		67	66	64	62	60	58	55	50	45	40
DLP20-60	7.5		81	79	77	75	73	70	66	61	55	49
DLP20-70	7.5		95	93	91	89	86	82	77	71	65	58
DLP20-80	9.2		109	107	105	102	99	94	89	82	75	67
DLP20-100	11		136	134	131	128	124	118	111	103	95	85
DLP20-120	15		164	162	158	154	149	142	133	124	114	102
DLP20-140	15		192	189	185	180	174	166	156	145	133	119
DLP20-170	18.5		234	230	225	219	212	202	190	177	162	145

单相电机、隔爆电机外形尺寸有所变动，详情请咨询本公司。

性能曲线

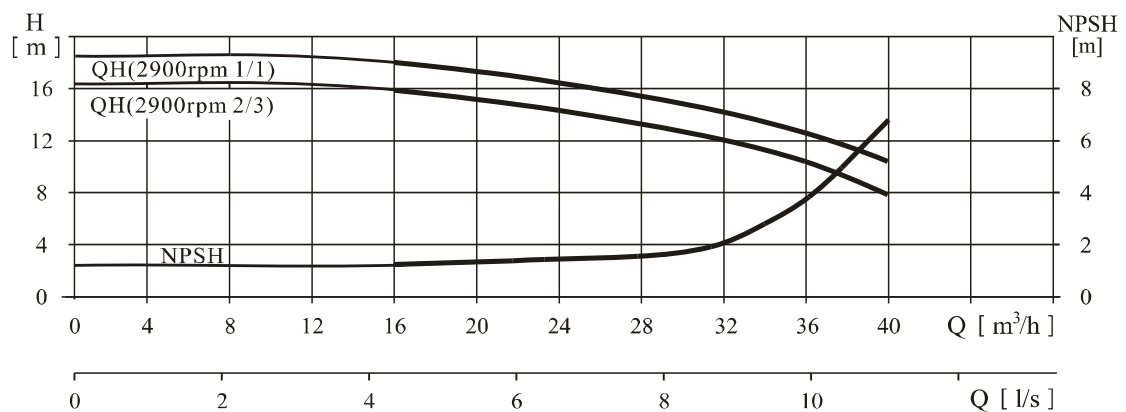
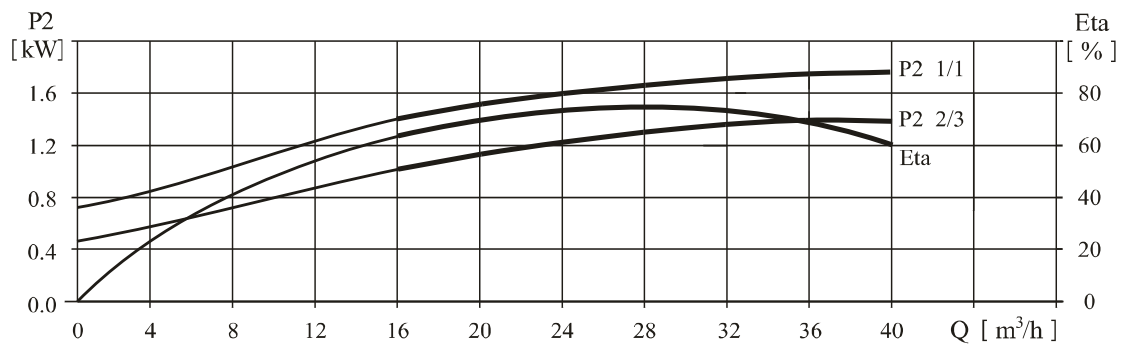
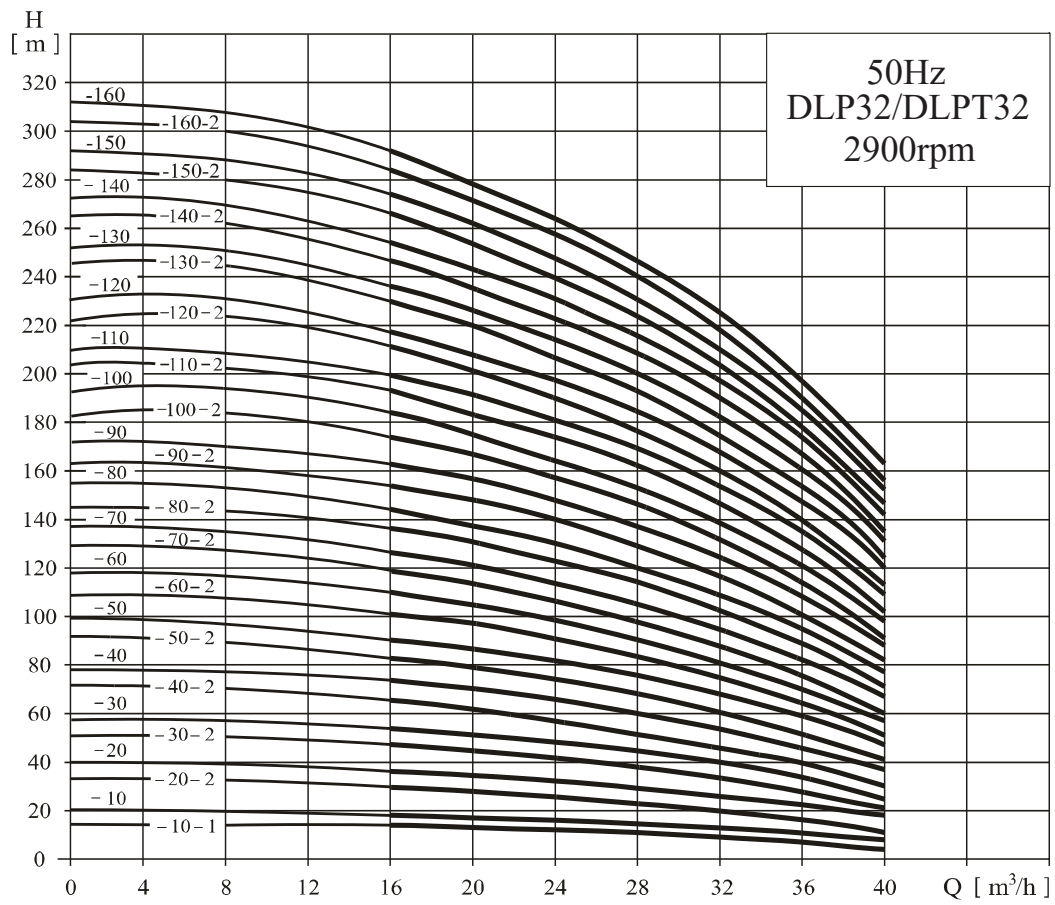

安装图

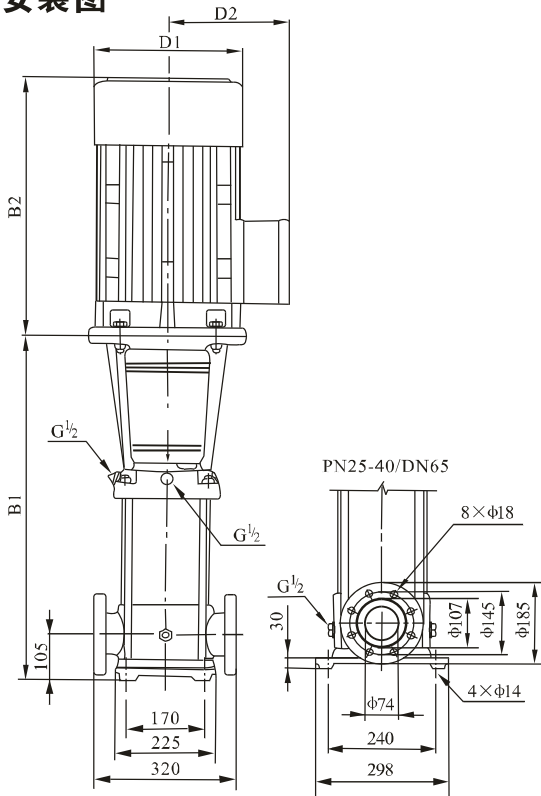

尺寸和重量

型号	尺寸(mm)					重量(kg)
	B1	B2	B1+B2	D1	D2	
DLP32-10-1/DLP32-10	505	290	795	190	155	64/68
DLP32-10-2/DLP32-20	575	345/355	920/930	197/230	165/180	77/85
DLP32-30-2/DLP32-30	645	390	1035	260	208	100
DLP32-40-2/DLP32-40	715	390	1105	260	208	109
DLP32-50-2/DLP32-50	785	390	1175	260	208	125
DLP32-60-2/DLP32-60	960	500	1460	330	255	185
DLP32-70-2/DLP32-70	1030	500	1530	330	255	199
DLP32-80-2/DLP32-80	1100	500	1600	330	255	203
DLP32-90-2/DLP32-90	1170	550	1720	330	255	222
DLP32-100-2/DLP32-100	1240	550	1790	330	255	227
DLP32-110-2/DLP32-110	1310	575	1885	360	285	272
DLP32-120-2/DLP32-120	1380	575	1955	360	285	276
DLP32-130-2/DLP32-130	1450	575	2025	360	285	293
DLP32-140-2/DLP32-140	1520	575/650	2095/2170	360/400	285/310	298/341
DLP32-150-2/DLP32-150	1590	650	2240	400	310	345
DLP32-160-2/DLP32-160	1660	650	2310	400	310	350

性能表

型号	配用电机 (kW)	Q (m ³ /h)	16	20	24	28	32	36	40
DLP32-10-1	1.5	H (m)	14	13	12	11	9	7	4
DLP32-10	2.2		18	17	15	14	13	11	8
DLP32-20-2	3.0		29	28	26	23	20	16	11
DLP32-20	4.0		36	34	32	29	27	23	18
DLP32-30-2	5.5		47	44	41	38	33	28	21
DLP32-30	5.5		54	51	48	44	40	35	27
DLP32-40-2	7.5		65	62	58	53	46	40	30
DLP32-40	7.5		72	69	65	59	53	47	37
DLP32-50-2	9.2		83	79	74	68	60	52	41
DLP32-50	9.2		90	86	81	74	67	59	47
DLP32-60-2	11		101	97	90	83	74	65	51
DLP32-60	11		108	104	97	90	81	72	57
DLP32-70-2	15		119	114	107	98	88	78	60
DLP32-70	15		126	121	113	105	95	85	67
DLP32-80-2	15		136	131	123	114	102	90	71
DLP32-80	15		144	138	130	120	109	97	77

型号	配用电机 (kW)	Q (m ³ /h)	16	20	24	28	32	36	40
DLP32-90-2	18.5	H (m)	154	148	140	129	117	102	82
DLP32-90	18.5		162	156	147	136	124	109	88
DLP32-100-2	18.5		175	166	157	146	131	115	91
DLP32-100	18.5		182	173	164	152	138	122	98
DLP32-110-2	22		193	184	173	164	146	128	102
DLP32-110	22		200	191	180	168	153	135	109
DLP32-120-2	22		211	201	189	178	160	140	113
DLP32-120	22		218	208	196	184	167	147	120
DLP32-130-2	26		230	218	206	193	174	153	124
DLP32-130	26		237	225	213	200	181	160	131
DLP32-140-2	26		247	235	222	210	189	165	135
DLP32-140	30		255	242	229	216	196	172	142
DLP32-150-2	30		266	253	239	224	203	178	145
DLP32-150	30		274	260	246	231	210	185	152
DLP32-160-2	30		284	270	255	240	218	190	156
DLP32-160	30		292	277	262	246	225	197	163

单相电机、隔爆电机外形尺寸有所变动，详情请咨询本公司。

性能曲线

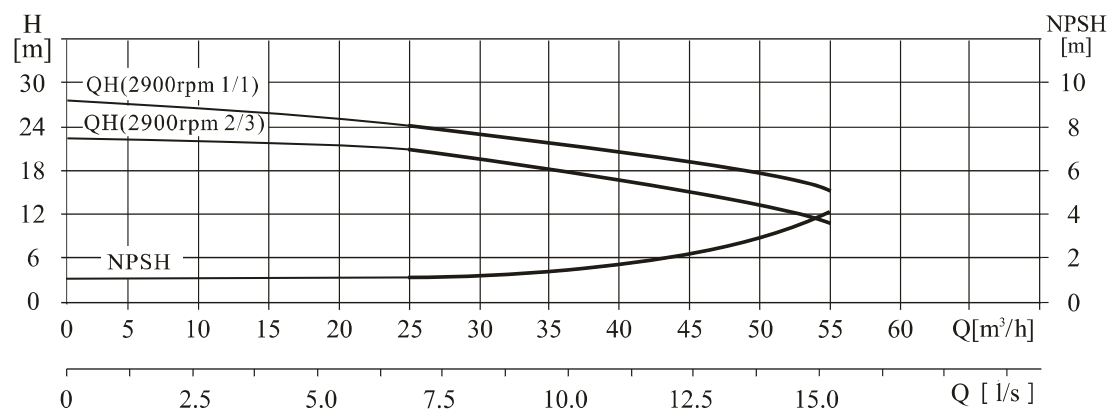
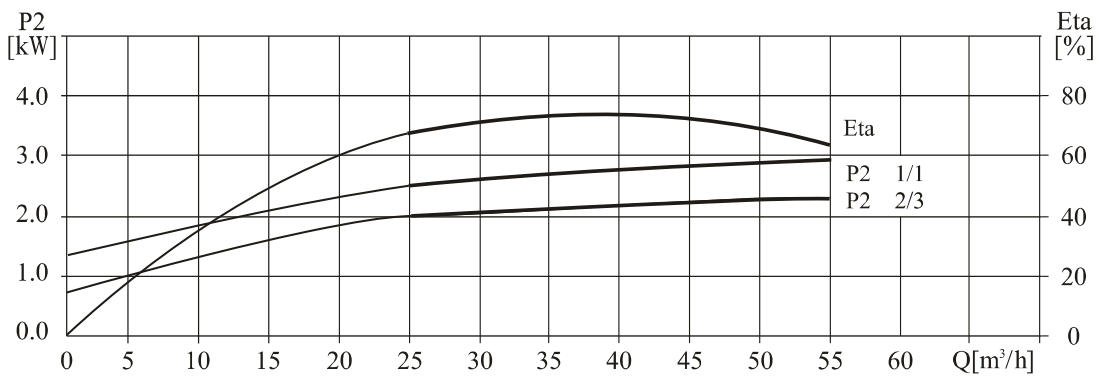
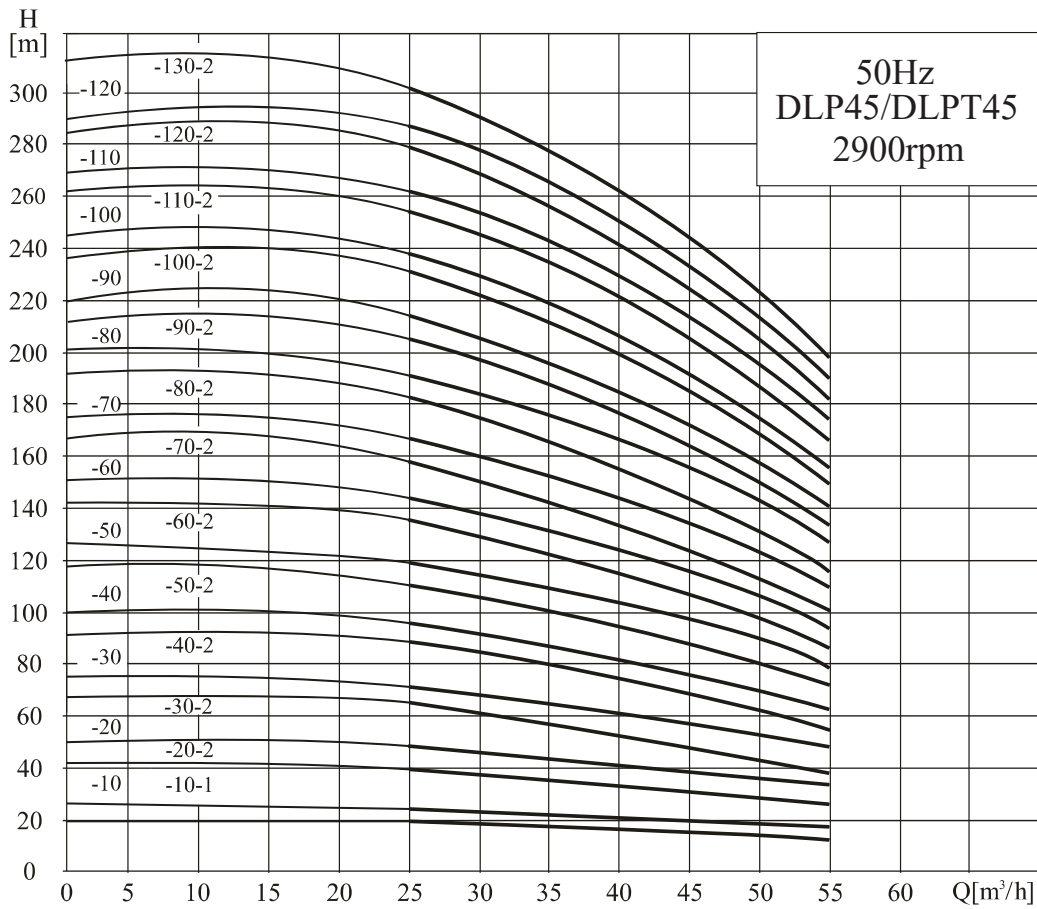

安装图

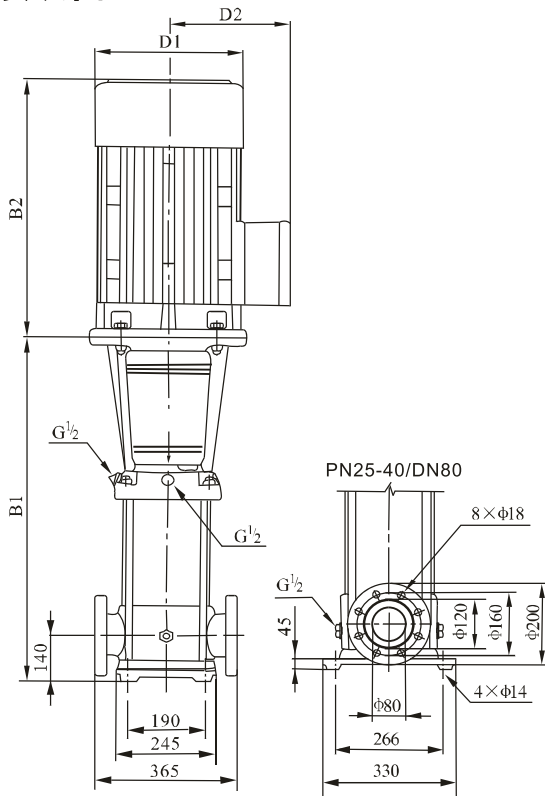

尺寸和重量

型号	尺寸(mm)					重量(kg)
	B1	B2	B1+B2	D1	D2	
DLP45-10-1	561	345/355	906/916	197/230	165/188	83/90
DLP45-10						
DLP45-20-2	641	390	1031	260	208	105/110
DLP45-20						
DLP45-30-2	721/826	390/500	1111/1326	260/330	208/255	127/183
DLP45-30						
DLP45-40-2	906	500	1406	330	255	197
DLP45-40						
DLP45-50-2	986	550	1536	330	255	221
DLP45-50						
DLP45-60-2	1066	575	1641	360	285	261
DLP45-60						
DLP45-70-2	1146	575	1721	360	285	288
DLP45-70						
DLP45-80-2	1226	650	1876	400	310	324
DLP45-80						
DLP45-90-2	1306	650	1956	400	310	328/352
DLP45-90						
DLP45-100-2	1386	650	2036	400	310	355
DLP45-100						
DLP45-110-2	1466	685	2151	450	345	426
DLP45-110						
DLP45-120-2	1546	685	2231	450	345	432
DLP45-120						
DLP45-130-2	1626	685	2311	450	345	438

性能表

型号	配用电机 (kW)	Q (m ³ /h)	H (m)							
			25	30	35	40	45	50	55	
DLP45-10-1	3.0	H (m)	20	19	18	17	15	13	11	
DLP45-10	4.0		24	23	22	21	19	18	16	
DLP45-20-2	5.5		40	38	36	33	30	27	23	
DLP45-20	7.5		48	46	44	42	39	35	31	
DLP45-30-2	9.2		63	61	58	54	50	44	38	
DLP45-30	11		71	69	66	63	58	53	47	
DLP45-40-2	15		87	84	80	75	69	62	54	
DLP45-40	15		95	92	88	84	78	71	62	
DLP45-50-2	18.5		111	107	102	96	88	80	69	
DLP45-50	18.5		119	115	110	105	97	88	78	
DLP45-60-2	22		135	130	124	117	108	97	85	
DLP45-60	22		143	138	132	125	116	106	93	
DLP45-70-2	26		158	152	146	138	127	115	100	
DLP45-70	26		166	161	154	146	135	124	109	
DLP45-80-2	30		182	175	168	159	146	133	116	
DLP45-80	30		190	184	176	167	154	141	124	
DLP45-90-2	30		205	198	190	180	166	150	132	
DLP45-90	37		214	207	198	188	174	159	140	
DLP45-100-2	37		230	221	212	200	185	168	147	
DLP45-100	37		238	230	220	209	193	177	155	
DLP45-110-2	45	255	246	236	223	206	188	165		
DLP45-110	45	263	255	244	232	214	196	173		
DLP45-120-2	45	280	270	259	245	226	206	181		
DLP45-120	45	289	280	268	255	236	216	190		
DLP45-130-2	45	305	294	282	267	247	225	198		

隔爆电机外形尺寸有所变动，详情请咨询本公司。

性能曲线

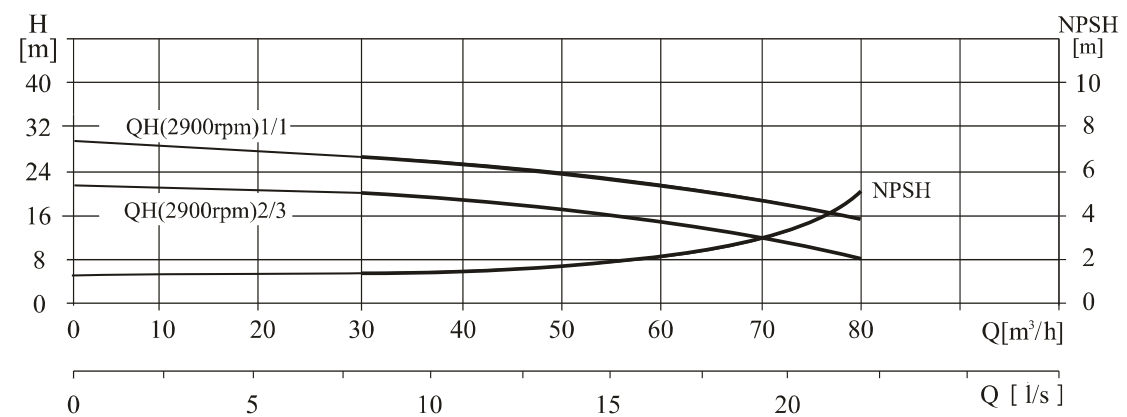
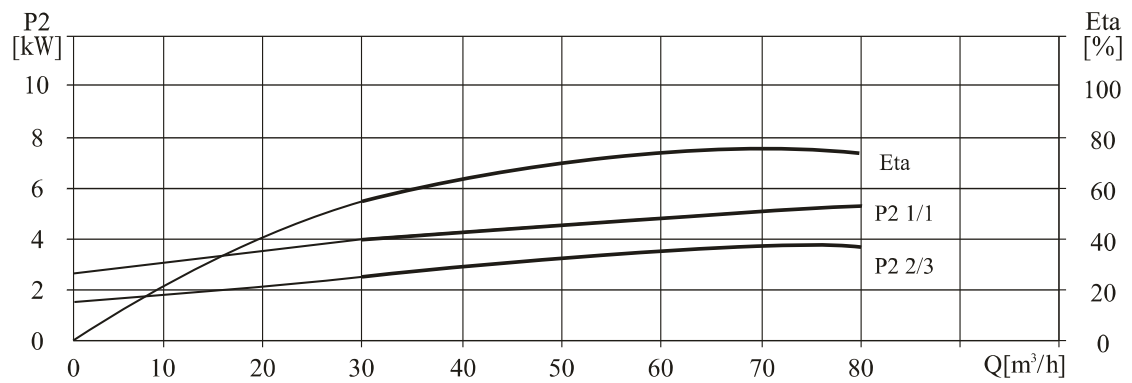
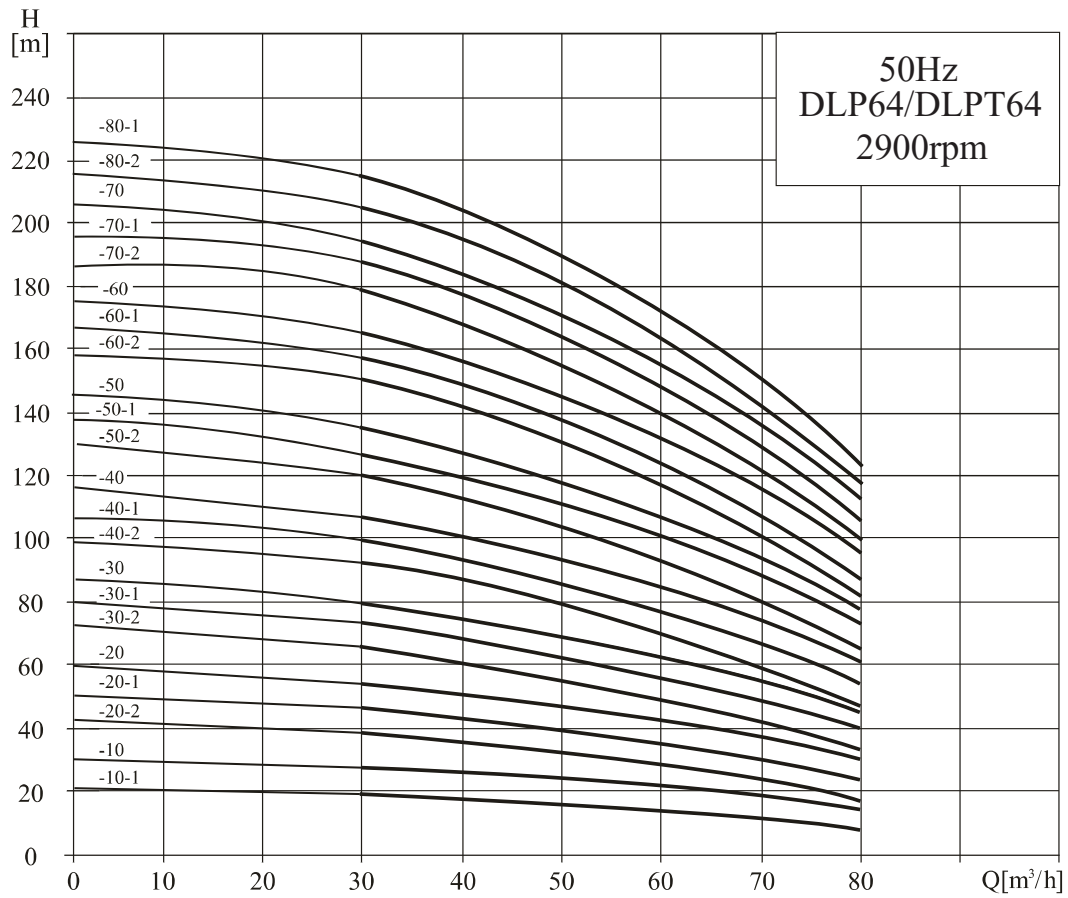

安装图

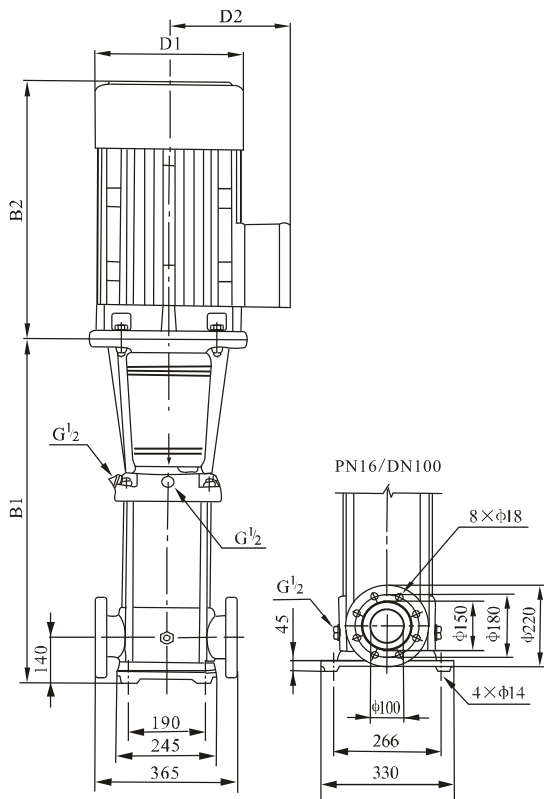

尺寸和重量

型号	尺寸(mm)					重量(kg)
	B1	B2	B1+B2	D1	D2	
DLP64-10-1	561	355	916	230	188	93
DLP64-10	561	390	951	260	208	105
DLP64-20-2	644	390	1034	260	208	110
DLP64-20-1	754	500	1254	330	255	182
DLP64-20	754	500	1254	330	255	182
DLP64-30-2	836	500	1336	330	255	196
DLP64-30-1	836	500	1336	330	255	197
DLP64-30	836	550	1386	330	255	221
DLP64-40-2	919	550	1469	330	255	225
DLP64-40-1	919	575	1494	360	285	258
DLP64-40	919	575	1494	360	285	258
DLP64-50-2	1001	575	1576	360	285	276
DLP64-50-1	1001	575	1576	360	285	276
DLP64-50	1001	650	1651	400	310	320
DLP64-60-2	1084	650	1734	400	310	325
DLP64-60-1	1084	650	1734	400	310	349
DLP64-60	1084	650	1734	400	310	349
DLP64-70-2	1166	650	1816	400	310	353
DLP64-70-1	1166	650	1816	400	310	353
DLP64-70	1166	685	1851	460	340	420
DLP64-80-2	1248	685	1933	460	340	424
DLP64-80-1	1248	685	1933	460	340	424

性能表

型号	配用电机 (kW)	Q (m ³ /h)	H (m)							
			30	40	50	60	64	70	80	
DLP64-10-1	4.0	H (m)	19	18	16	14	13	11	8	
DLP64-10	5.5		27	25	23	21	20	18	15	
DLP64-20-2	7.5		39	36	33	29	27	23	17	
DLP64-20-1	11		46	44	40	36	34	30	24	
DLP64-20	11		53	51	47	43	41	37	30	
DLP64-30-2	15		66	62	56	50	47	41	32	
DLP64-30-1	15		73	69	63	57	54	48	39	
DLP64-30	18.5		80	76	70	64	61	55	46	
DLP64-40-2	18.5		92	87	80	71	67	60	47	
DLP64-40-1	22		100	94	87	78	74	67	54	
DLP64-40	22		107	101	94	85	81	74	61	
DLP64-50-2	26		121	114	105	95	89	80	64	
DLP64-50-1	26		128	121	112	102	96	87	71	
DLP64-50	30		136	129	119	109	103	94	78	
DLP64-60-2	30		150	142	131	118	111	101	81	
DLP64-60-1	37		157	149	138	125	118	108	88	
DLP64-60	37		164	156	145	132	125	115	95	
DLP64-70-2	37		179	169	156	141	133	121	99	
DLP64-70-1	37		186	176	163	148	141	128	106	
DLP64-70	45		193	183	170	155	148	135	112	
DLP64-80-2	45	207	196	182	164	156	142	116		
DLP64-80-1	45	215	203	189	171	163	149	123		

防爆电机外形尺寸有所变动，详情请咨询本公司；SDL64系列可安客户要求供应PN25-40/DN100标准法兰。

性能曲线

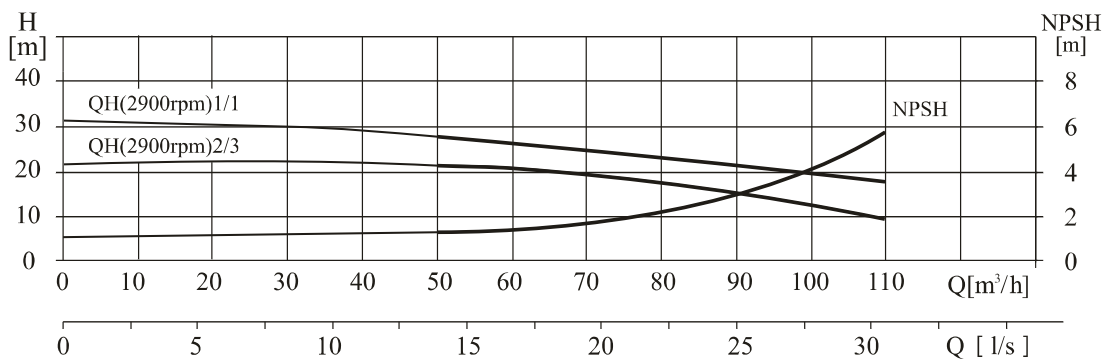
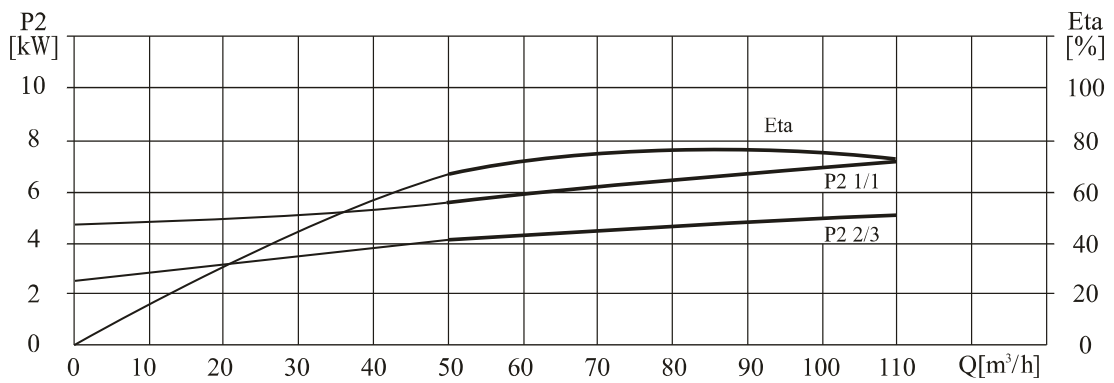
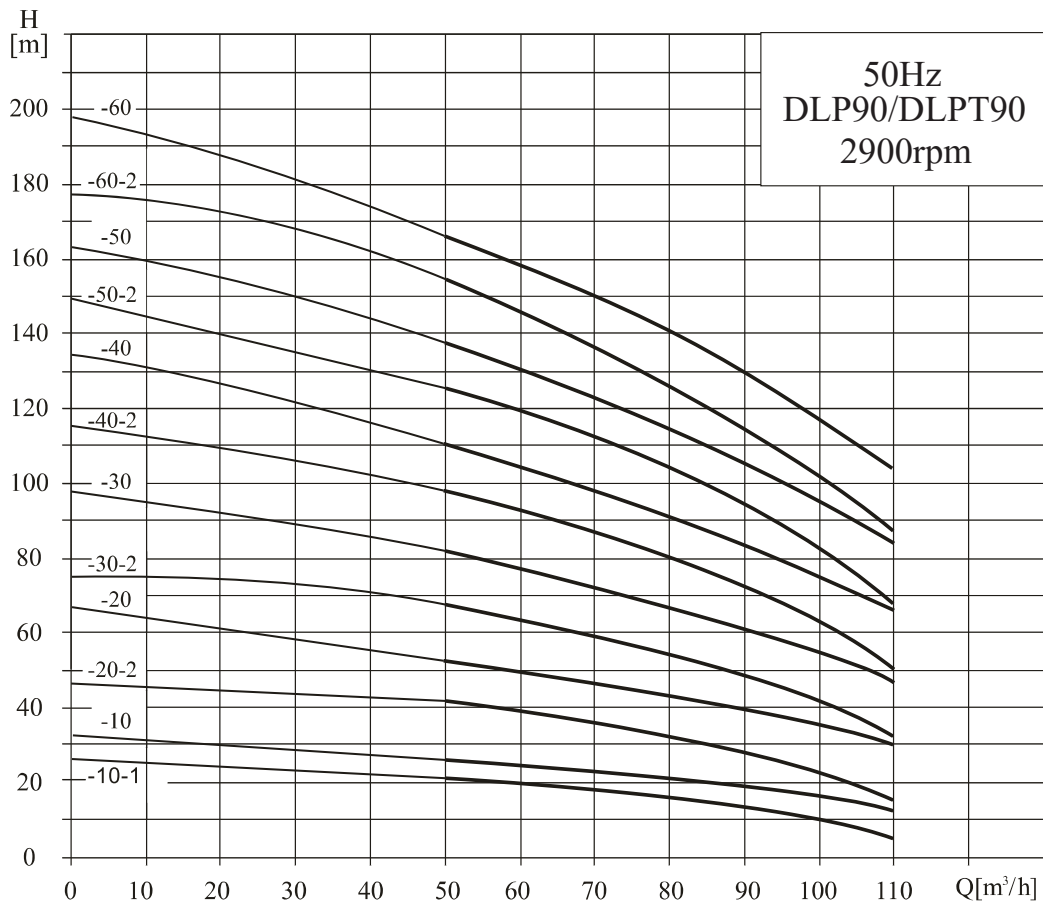

安装图

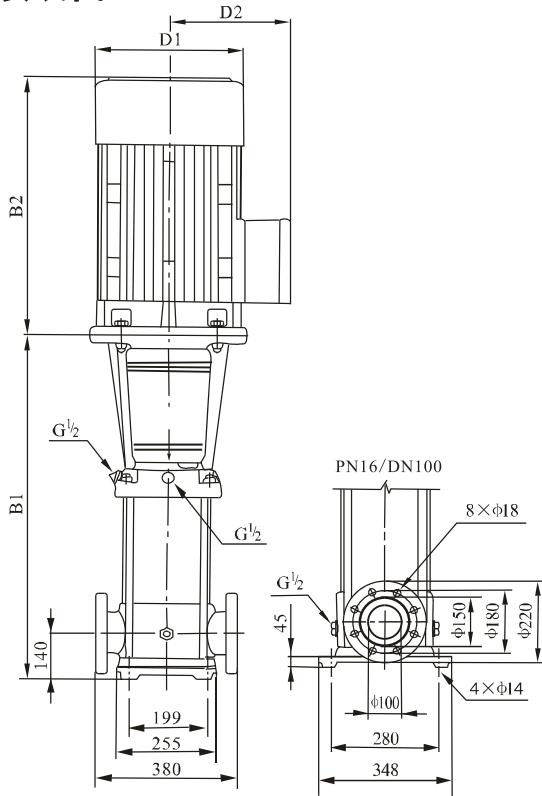

尺寸和重量

型号	尺寸(mm)					重量(kg)
	B1	B2	B1+B2	D1	D2	
DLP90-10-1	571	390	961	260	208	105
DLP90-10	571	390	961	260	208	110
DLP90-20-2	773	500	1273	330	255	181
DLP90-20	773	500	1273	330	255	192
DLP90-30-2	865	550	1415	330	255	215
DLP90-30	865	575	1440	360	285	252
DLP90-40-2	957	575	1532	360	285	271
DLP90-40	957	650	1607	400	310	312
DLP90-50-2	1049	650	1699	400	310	336
DLP90-50	1049	650	1699	400	310	336
DLP90-60-2	1141	685	1826	460	340	407
DLP90-60	1141	685	1826	460	340	407

性能表

型号	配用电机 (kW)	Q (m ³ /h)	H (m)							
			50	60	70	80	90	100	110	
DLP90-10-1	5.5	H (m)	22	19	17	16	13	10	6	
DLP90-10	7.5		25	24	22	21	19	16	12	
DLP90-20-2	11		41	39	36	32	28	22	15	
DLP90-20	15		53	50	47	44	40	36	30	
DLP90-30-2	18.5		68	65	60	55	49	41	32	
DLP90-30	22		81	77	72	67	62	55	48	
DLP90-40-2	26		98	93	87	80	72	62	50	
DLP90-40	30		110	105	100	92	84	76	66	
DLP90-50-2	37		126	120	113	104	93	81	68	
DLP90-50	37		139	131	124	115	106	94	83	
DLP90-60-2	45		155	148	139	129	117	102	86	
DLP90-60	45		168	160	150	141	130	117	103	

隔爆电机外形尺寸有所变动，详情请咨询本公司；SDL90系列可安客户要求供应PN25-40/DN100标准法兰。

性能曲线

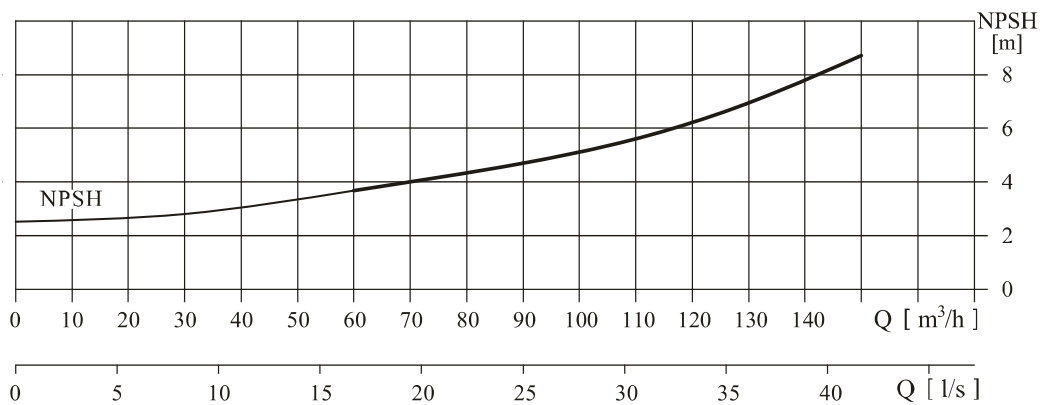
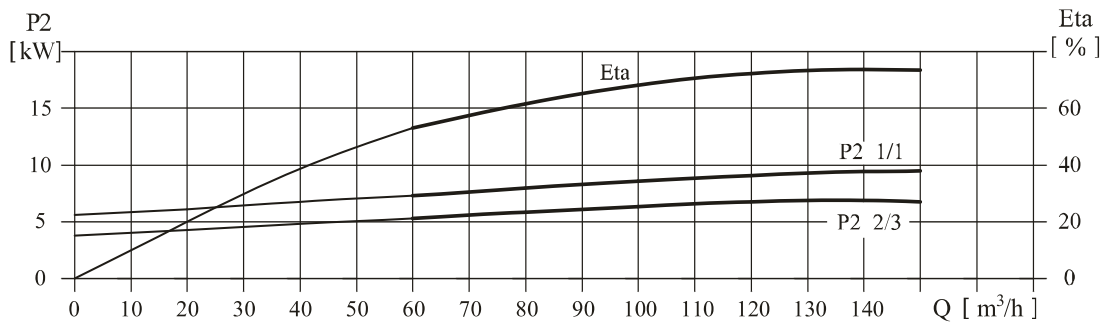
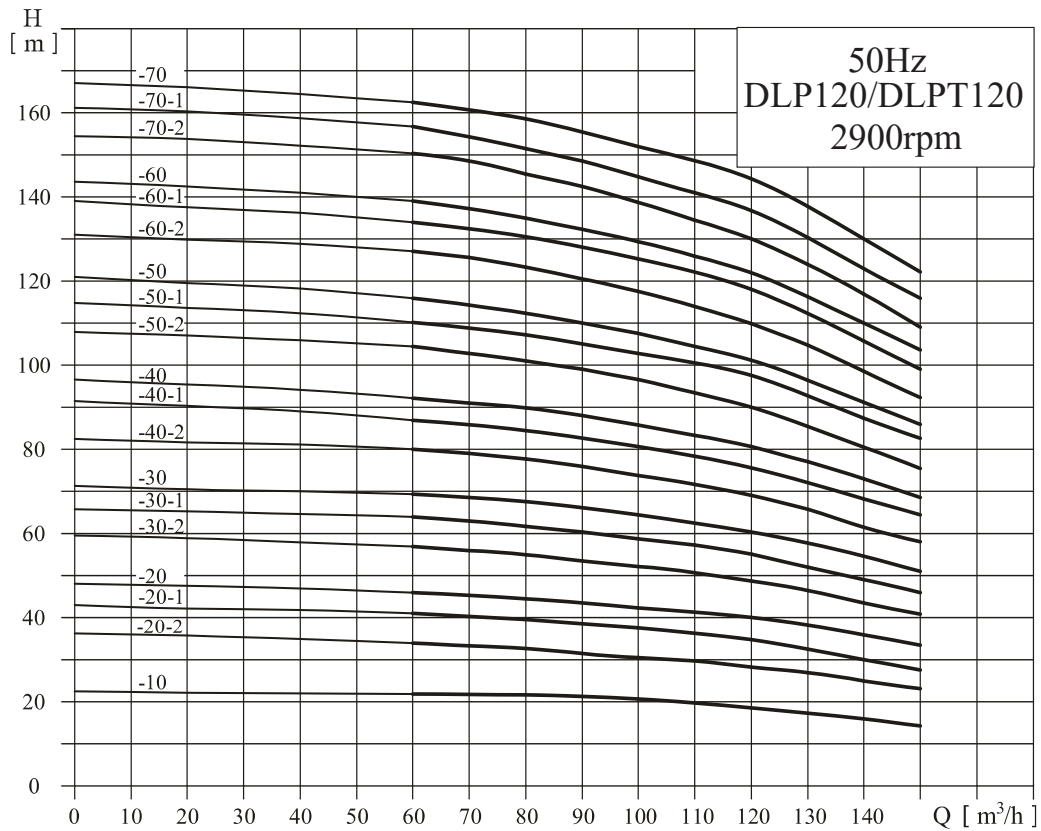

安装图

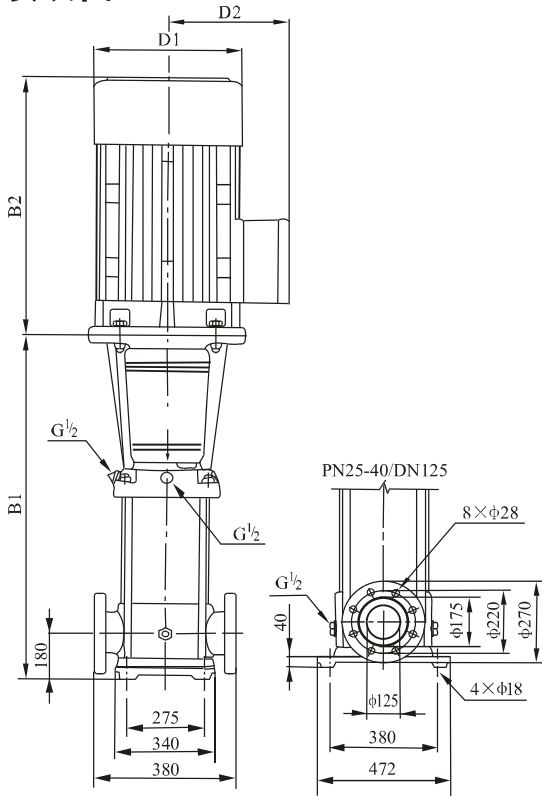

尺寸和重量

型号	尺寸(mm)					重量(kg)
	B1	B2	B1+B2	D1	D2	
DLP120-10	840	500	1340	330	255	230
DLP120-20-2	1000	500	1500	330	255	245
DLP120-20-1	1000	550	1550	330	255	250
DLP120-20	1000	575	1575	360	285	285
DLP120-30-2	1160	575	1735	360	285	326
DLP120-30-1	1160	650	1810	400	310	360
DLP120-30	1160	650	1810	400	310	360
DLP120-40-2	1320	650	1970	400	310	400
DLP120-40-1	1320	650	1970	400	310	400
DLP120-40	1320	685	2005	460	340	460
DLP120-50-2	1480	685	2165	460	340	470
DLP120-50-1	1480	685	2165	460	340	470
DLP120-50	1510	760	2270	540	370	575
DLP120-60-2	1670	760	2430	540	370	585
DLP120-60-1	1670	760	2430	540	370	585
DLP120-60	1830	845	2515	580	410	705
DLP120-70-2	1830	845	2675	580	410	715
DLP120-70-1	1830	845	2675	580	410	715
DLP120-70	1830	845	2675	580	410	715

性能表

型号	配用电机 (kW)	Q (m ³ /h)	H (m)											
			60	70	80	90	100	110	120	130	140	150		
DLP120-10	11	H (m)	22	21.8	21.6	21	20.5	19.5	18.5	17	16	15		
DLP120-20-2	15		34	33.6	33	31	30.2	30	28.5	27	25	24		
DLP120-20-1	18.5		41	40	39.5	38.5	37	36.5	34.5	32.5	30	27.5		
DLP120-20	22		46	45	44.5	43.5	42.4	41	40	38	36	33.5		
DLP120-30-2	26		57	56	55	53.5	52	51	49	46.5	43.5	41		
DLP120-30-1	30		64	63	62	60	58.5	57.5	55.5	52	49	46		
DLP120-30	30		69.5	68.5	67.5	66	64.4	62.5	61	57.5	54.5	51		
DLP120-40-2	37		80.5	79	78	76	73.5	72	69	66	61.5	58		
DLP120-40-1	37		87	86	84.5	82	80	78	76	72	68	64.5		
DLP120-40	45		92.5	91	90	88	85.5	83	81	77	73	68.5		
DLP120-50-2	45		104.5	103	101	99	96	93	90	85.5	80.5	75.5		
DLP120-50-1	45		110.5	109	107.5	105	102	100	97	92	86.5	83		
DLP120-50	55		115.5	114	113	110	107.5	104.5	101.5	96	91	86		
DLP120-60-2	55		128	125.5	123	121	117.3	113.5	110	104.5	98.5	92.5		
DLP120-60-1	55		134	132	130.5	127	124	121	118	111	105	100		
DLP120-60	75		139	137	135	132	128.8	126	123	116	110	104		
DLP120-70-2	75		151	148	145.5	143	138.6	134	130	123.5	116.5	109		
DLP120-70-1	75		156.5	154	152	148.5	144.5	141	137.5	130	123	116.5		
DLP120-70	75		162.5	160.5	158.5	155	151	148	145	137	129	123		

隔爆电机外形尺寸有所变动, 详情请咨询本公司。

性能曲线

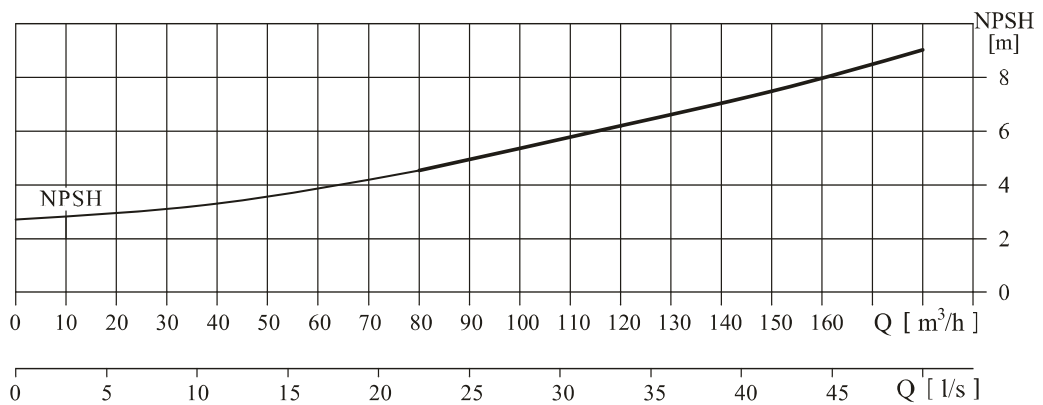
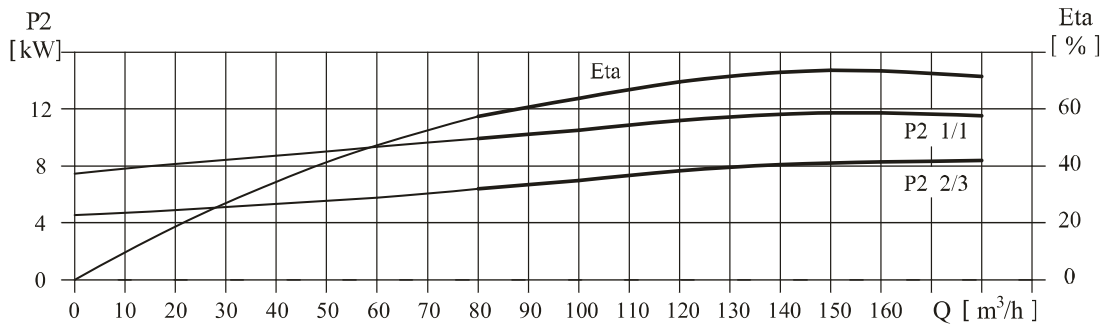
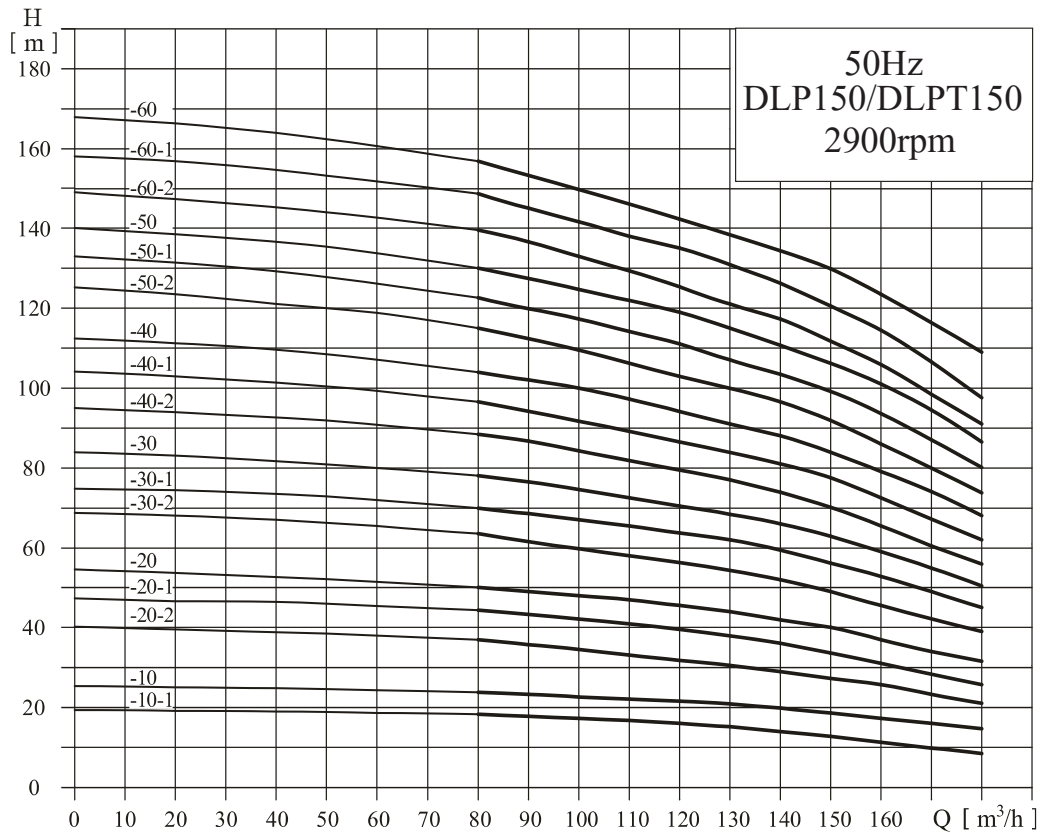

安装图

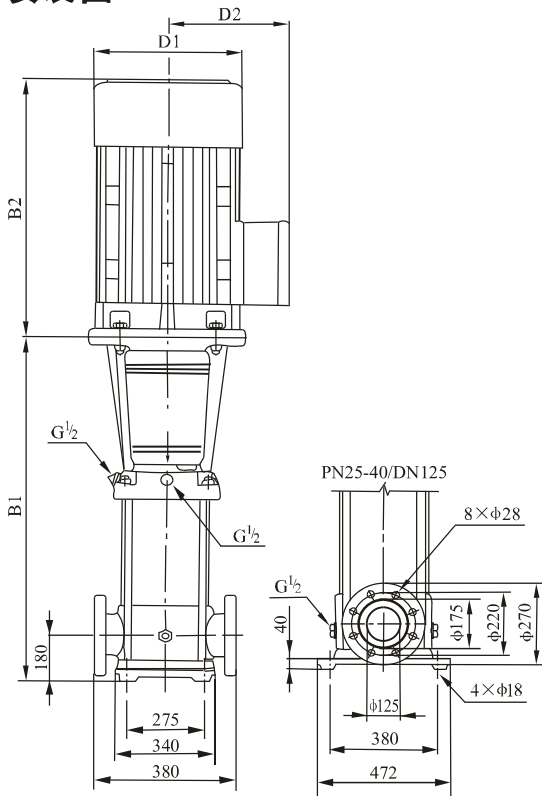

尺寸和重量

型号	尺寸(mm)					重量(kg)
	B1	B2	B1+B2	D1	D2	
DLP150-10-1	840	500	1340	330	255	230
DLP150-10	840	500	1340	330	255	235
DLP150-20-2	1000	550	1550	330	255	250
DLP150-20-1	1000	575	1575	360	285	295
DLP150-20	1000	575	1575	360	285	317
DLP150-30-2	1160	650	1810	400	310	360
DLP150-30-1	1160	650	1810	400	310	360
DLP150-30	1160	650	1810	400	310	385
DLP150-40-2	1320	685	2005	460	340	460
DLP150-40-1	1320	685	2005	460	340	460
DLP150-40	1350	760	2110	540	370	560
DLP150-50-2	1510	760	2270	540	370	570
DLP150-50-1	1510	845	2355	580	410	690
DLP150-50	1510	845	2355	580	410	690
DLP150-60-2	1670	845	2515	580	410	700
DLP150-60-1	1670	845	2515	580	410	700
DLP150-60	1670	845	2515	580	410	700

性能表

型号	配用电机 (kW)	Q (m ³ /h)	H (m)											
			80	90	100	110	120	130	140	150	160	170	180	
DLP150-10-1	11	H (m)	18.3	17.8	17.3	17	16	15	14	12.5	11	10	8.5	
DLP150-10	15		24	23	22.5	22	21.5	20.5	20	18.5	17	16	15	
DLP150-20-2	18.5		37	35.5	34	33	32	31	29	27.5	26	23	21	
DLP150-20-1	22		44.3	43	42	40	39	38.5	37.5	35	33	30	27	
DLP150-20	26		50	49	48	47	45.5	44	42	40	37	34	32	
DLP150-30-2	30		63.5	61	59	57.5	56	54.5	53	49	45.5	42	39	
DLP150-30-1	37		70	68	67	65	63	62	60	56	53	49	45	
DLP150-30	37		78	76.5	75	73	70.5	68	66	63	59	55	50.5	
DLP150-40-2	45		89	87	84	81.5	79	77	74.5	70.5	65.5	60	56	
DLP150-40-1	45		96.5	94	91.5	89	86.5	84	81.5	77	72.5	67	62	
DLP150-40	55		104	102	100	97	95	91	88	84	79.5	74	68	
DLP150-50-2	55		115.5	112	109	106	102.5	100	97	92	86	79	73.5	
DLP150-50-1	75		122.5	119.5	117	113.5	111.5	107.5	104.5	99	93.5	87	80	
DLP150-50	75		130	127.5	125	121	119	115	111.5	106.5	101	94.5	86.5	
DLP150-60-2	75		140	137	133	130	126	121	118	112	106	98	91	
DLP150-60-1	75		148.5	145	141.7	137.5	135	131	127	120.5	114.5	106.5	97.5	
DLP150-60	75		157	153	149	145	142	139.5	137	130	123.5	116	109	

隔爆电机外形尺寸有所变动，详情请咨询本公司。

性能曲线

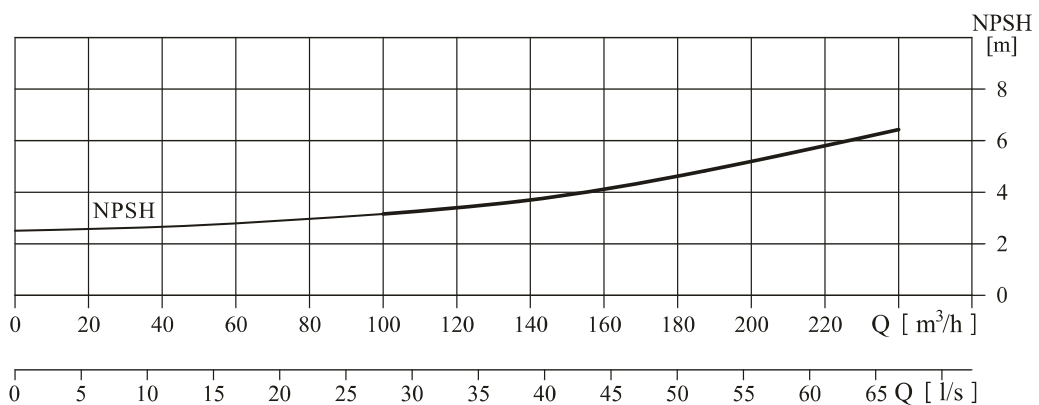
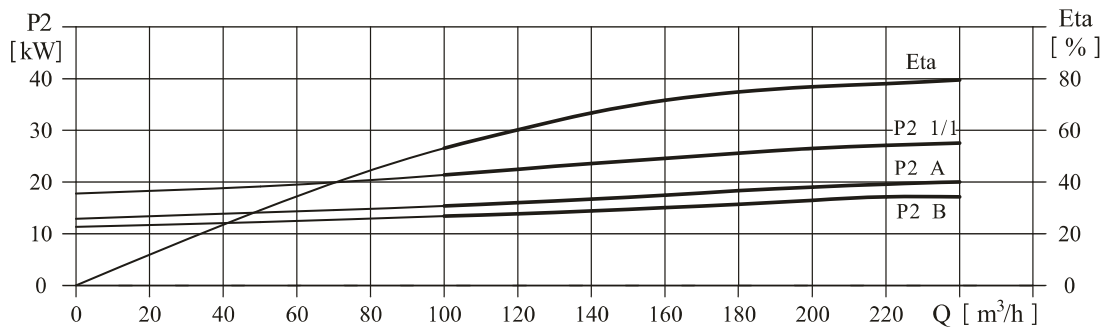
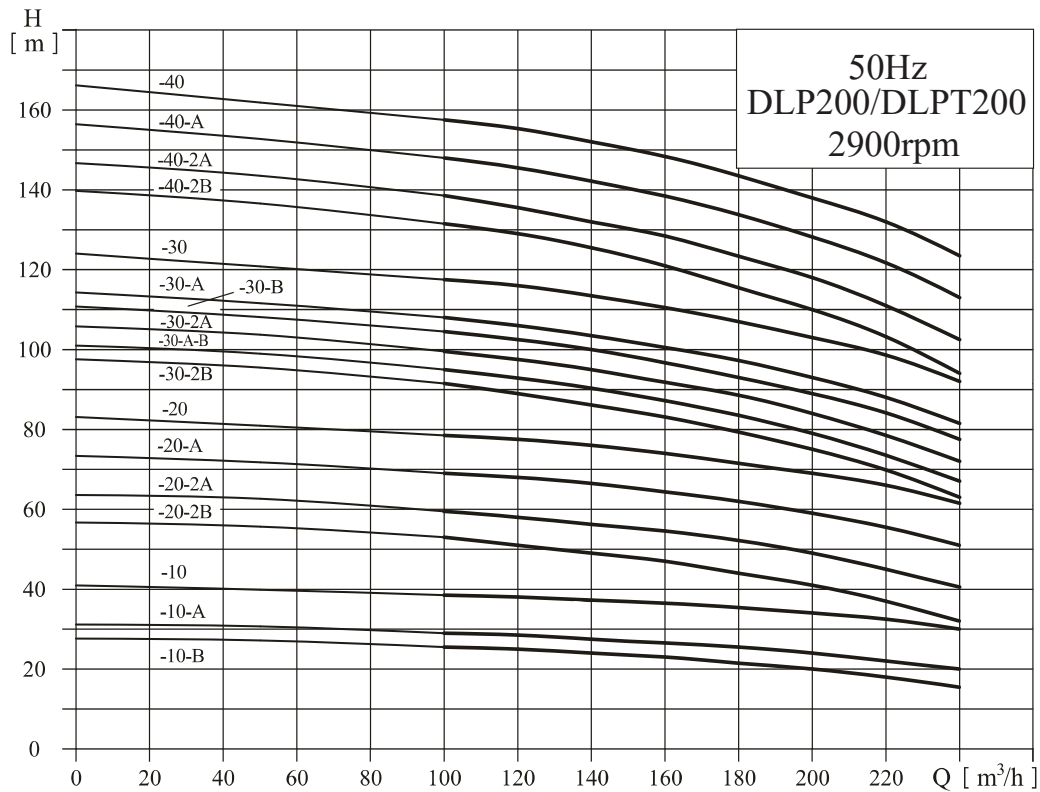

安装图

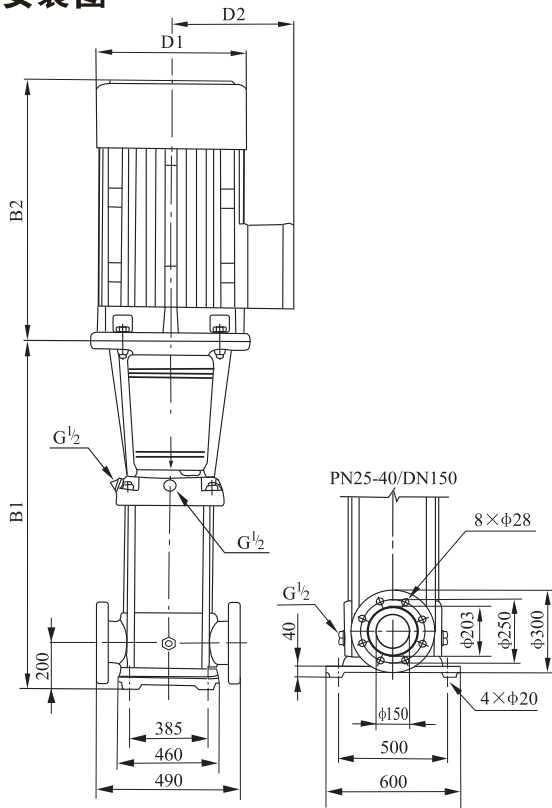

尺寸和重量

型号	尺寸(mm)					重量(kg)
	B1	B2	B1+B2	D1	D2	
DLP200-10-B	907	550	1457	330	255	311
DLP200-10-A	907	575	1482	360	285	347
DLP200-10	907	650	1557	400	310	403
DLP200-20-2A	1101	650	1751	400	310	447
DLP200-20-2B	1101	685	1786	460	340	504
DLP200-20-2A	1131	760	1891	540	370	595
DLP200-20	1131	760	1891	540	370	595
DLP200-30-2B	1325	845	2170	580	410	748
DLP200-30-A-B	1325	845	2170	580	410	748
DLP200-30-2A	1325	845	2170	580	410	748
DLP200-30-B	1325	845	2170	580	410	748
DLP200-30-A	1325	845	2170	580	410	748
DLP200-30	1325	895	2220	580	410	817
DLP200-40-2B	1519	895	2414	580	410	830
DLP200-40-2A	1519	1140	2659	645	550	1180
DLP200-40-A	1519	1140	2659	645	550	1180
DLP200-40	1519	1140	2659	645	550	1180

性能表

型号	配用电机 (kW)	Q (m ³ /h)	100	120	140	160	180	200	220	240
			H (m)	25.5	25	24	23	21.5	20	18
DLP200-10-B	18.5	H (m)	29	28.5	27.5	26.5	25.5	24	22	20
DLP200-10-A	22		38.5	38	37.5	36.5	35	34	32.5	30
DLP200-10	30		53	51	49	47	44	41	37	32
DLP200-20-2A	37		59.5	58	56	54	52.5	49	44.5	40.5
DLP200-20-2B	45		69	68	66	64	62	59	55.5	51
DLP200-20-2A	55		78.5	77.5	76	74	71.5	69	66	61.5
DLP200-20	55		91.5	89	86.5	83.5	79	75	70	63
DLP200-30-2B	75		95	93	90	87	83.5	79	73.5	67
DLP200-30-A-B	75		99.5	97.5	94.5	91.5	89	84	78.5	72
DLP200-30-2A	75		104.5	102.5	100	97	93	89	84.5	77.5
DLP200-30-B	75		108	106	103.5	100.5	97.5	93	88	81.5
DLP200-30-A	75		117.5	116	113.5	110.5	107	103	99	92
DLP200-30	90		131.5	129	125.5	121	115.5	110	103.5	94
DLP200-40-2B	90		138.5	136	132	128	124	118	111	102.5
DLP200-40-2A	110		148	145.5	142.5	138	134	128	122	113
DLP200-40-A	110		157.5	155.5	152.5	148	143.5	138	132.5	123.5
DLP200-40	110									

隔爆电机外形尺寸有所变动，详情请咨询本公司。