

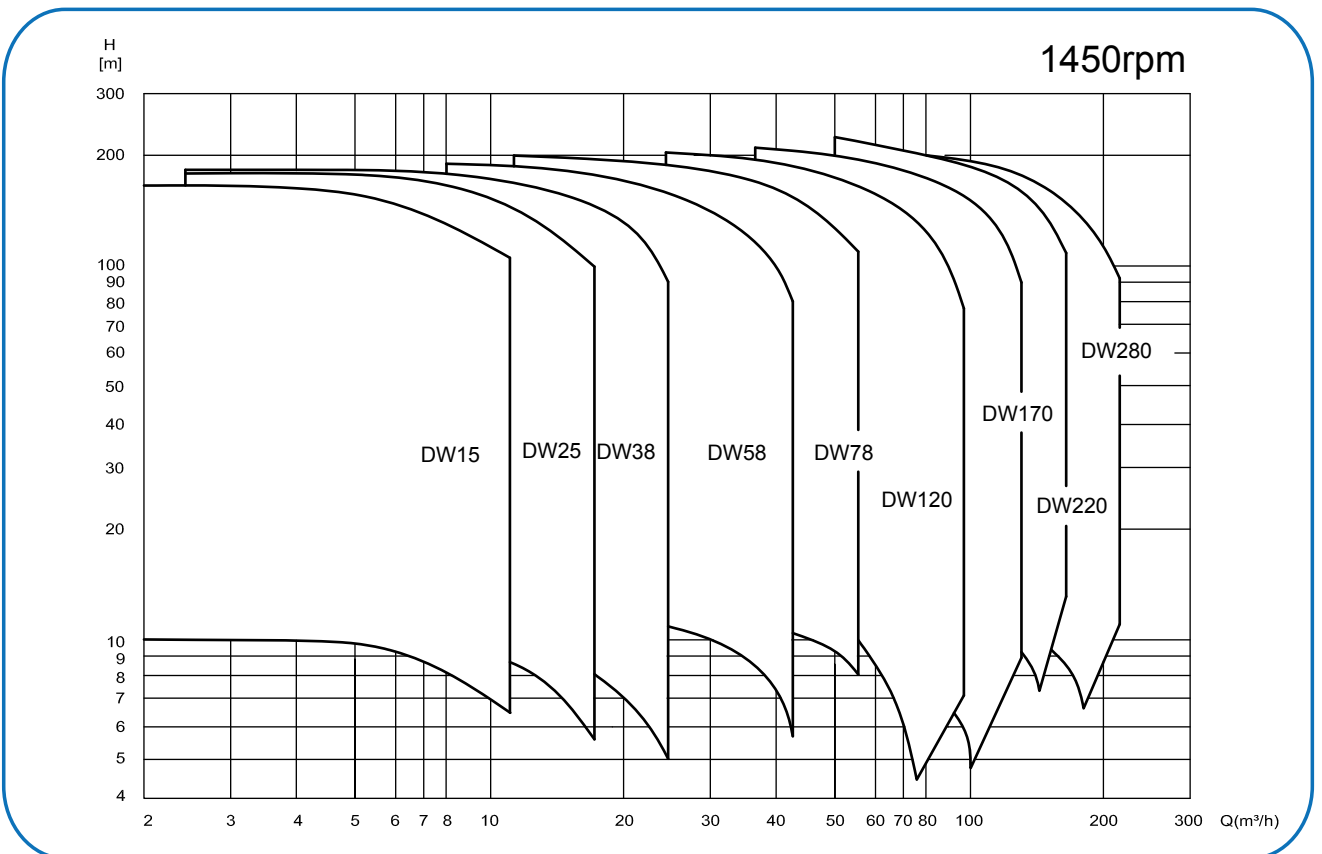

**DW Horizontal Multistage
Cast Stainless Steel Pump**

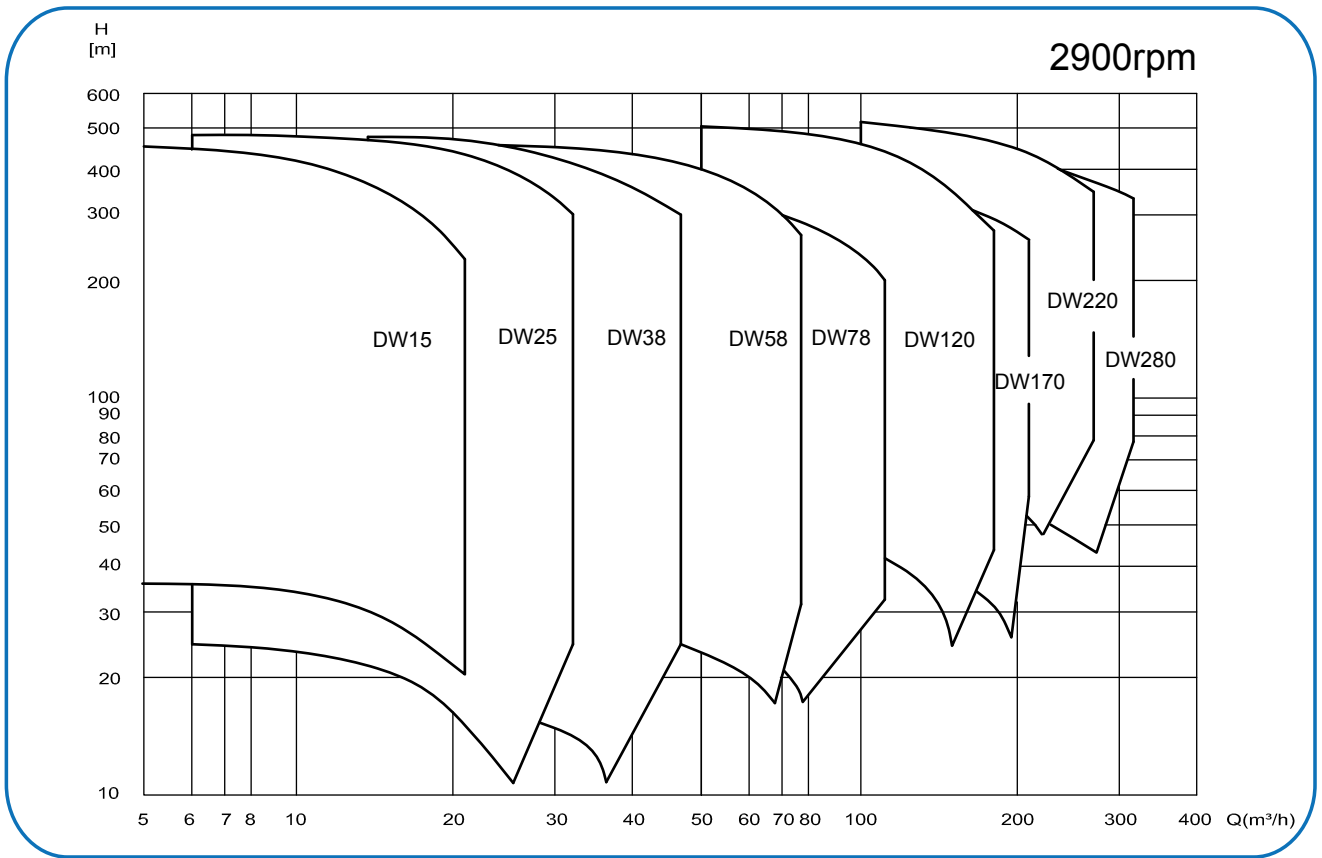



Application

- General water supply
- Pressure boosting
- Municipal water supply
- Drinking water supply
- Irrigation
- Heating
- Boiler feed water
- Fire-fighting system

Operation data

Pump size : DN 25 up to 150
 Capacities : Flow up to 350M3/hr
 Heads : Up to 510M
 Operating temp: 0-150 C in standard version
 Operating pressure: 10 up to 63 Bar
 Standard Flange
 Suction nozzle PN10/PN16
 Discharge nozzle PN25/PN40/PN63

Design

DW in ring section design. Axial or radial suction/discharge. The section, comprising an impeller and diffuser, are held together by generously proportioned tie bar. The impellers are arranged in series on a common shaft.

Motor

All pumps are coupled with short circuit squirrel cage Motor, totally enclosed, fan-cooled. IE3 high efficiency IP55 and class F insulation

Material

The pump pressure are cast in a variety of materials, selected to suit the working pressure of the pump, and to be compatible with the liquid being handle. Standard materials are:

- * Cast Iron
- * Ductile Iron
- * Cast 304 & 316 Stainless Steel
- Cast duplex Stainless Steel
- Cast Bronze & Zinc free Bronze

Seal

A shaft seal is fitted to prevent leakage of high pressure water at the points where the shaft enters the pump body. Mechanical seals are used in a variety of different arrangements to suit the application and meet customer's preference.

Designation

DW 15, 25, 38, 58, 78, 120, 170, 220, 280

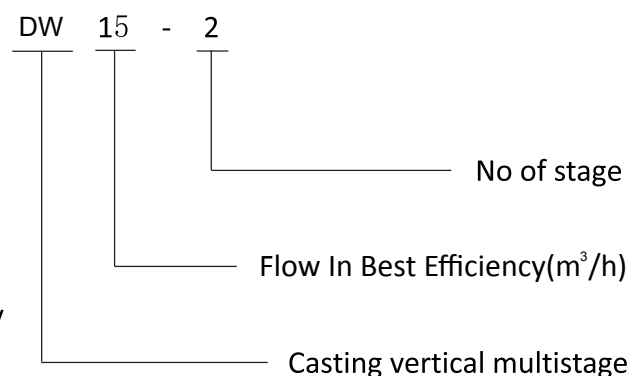

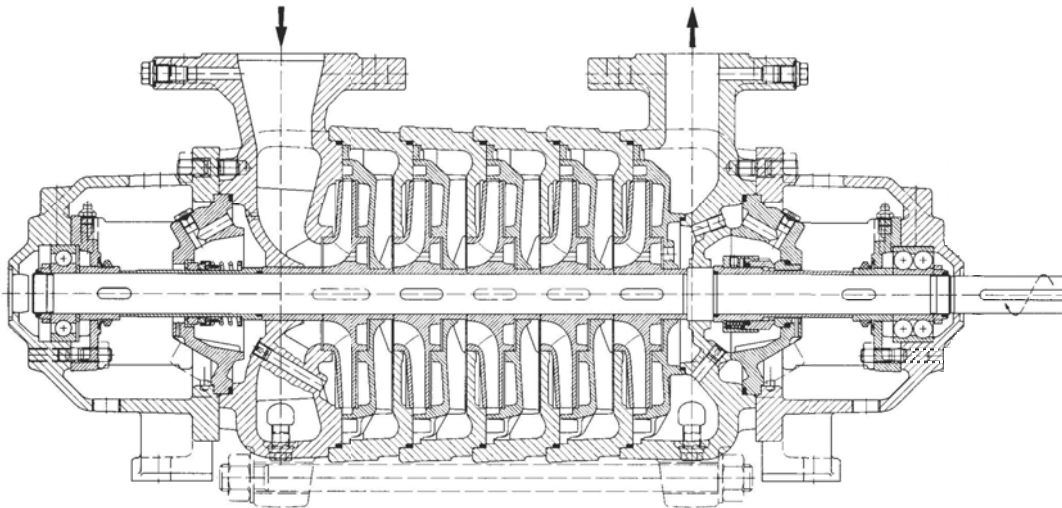

- Horizontal configuration with outer bearings on both sides.
- Driven by electric motors, combustion engines or steam turbines via flexible coupling.
- Drive end discharge, clockwise rotation (Counter clockwise rotation available with drive end on suction side)
- Branch directions: suction left viewed from drive end, discharge radially upwards.
Branches can be adjusted to meet customer requirements in 90° increments.
- Drive end thrust bearing, double row bearing. Suction side ball bearing, grease lubrication with grease nipples.
- Thermal expansion of the pump rotor will be balanced internally without affecting the coupling alignment.
- Shaft sealing arrangements (mechanical seal or gland packing) as per „shaft sealing options“.
- Maintenance friendly design. Bearings and shaft seal are maintainable without pump disassembly.

Shaft Seal Options

Mechanical seal:

Seal chamber dimensions comply with ISO 3096. Mechanical seals of all brands that comply with this standard and EN 12756, version „k“ can be used without modification of the standard parts.

The taper bore type seal chamber is self venting and guarantees optimum lubrication and cooling of the seal faces.

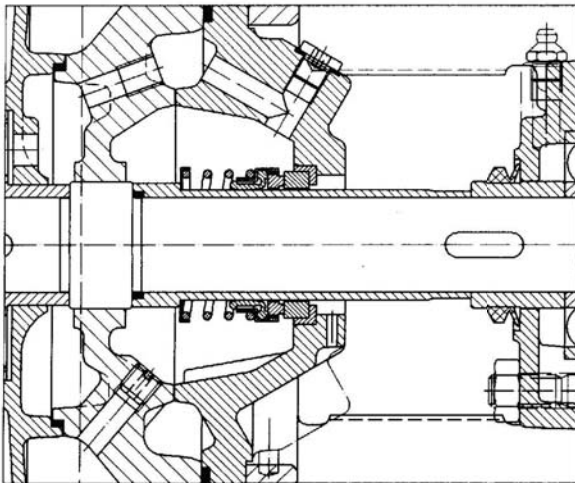

Single mech. seal, design U
unbalanced up to max. 16bar

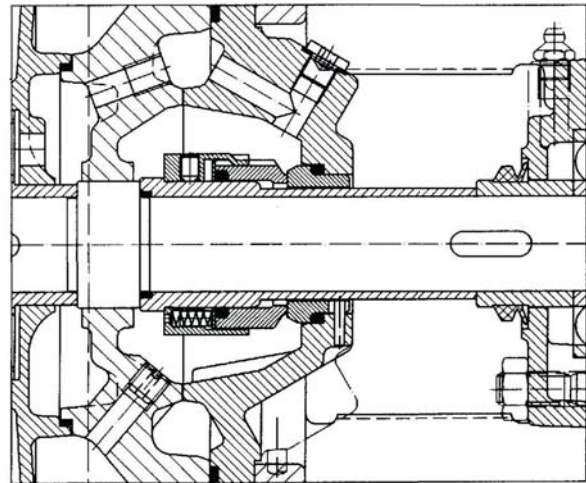

Single mech. seal, design B
balanced up to max. 55bar

For more detailed information about operation limits with regard to material configuration and operation conditions please refer to data sheets or actual quotations.

Gland packing:

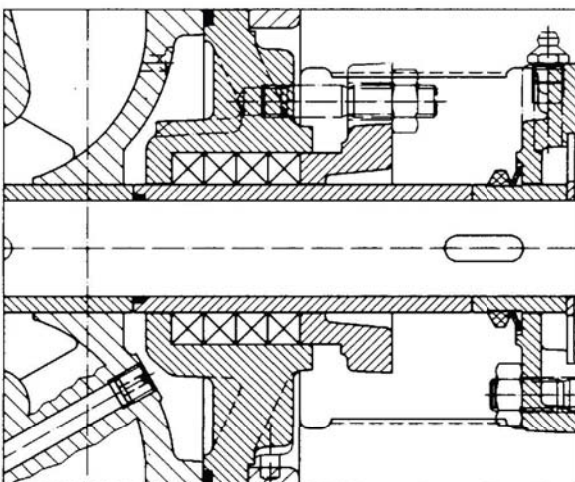

The availability of gland packings is limited to max. operation pressure of 25bar.

Above 25bar operation pressure only mechanical seals are available.

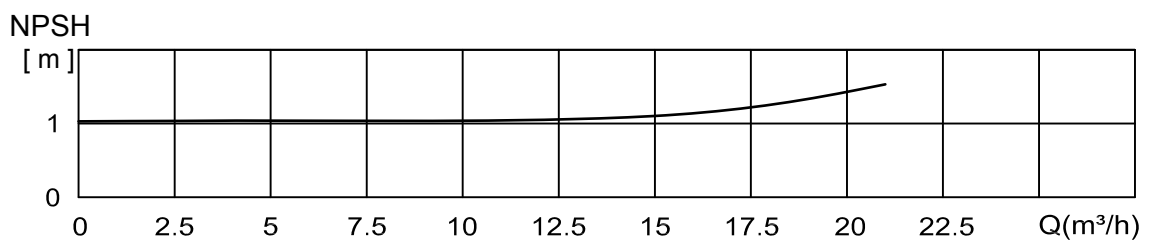
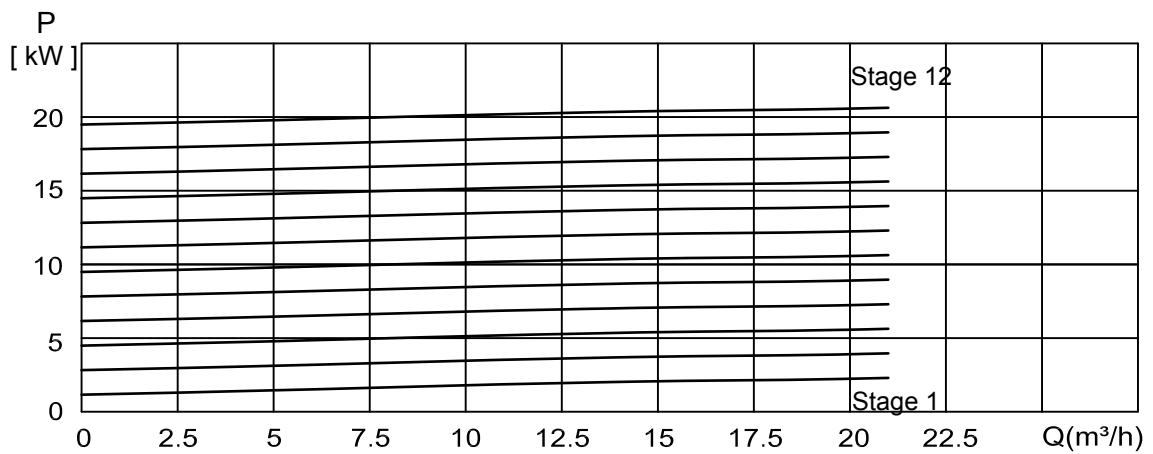
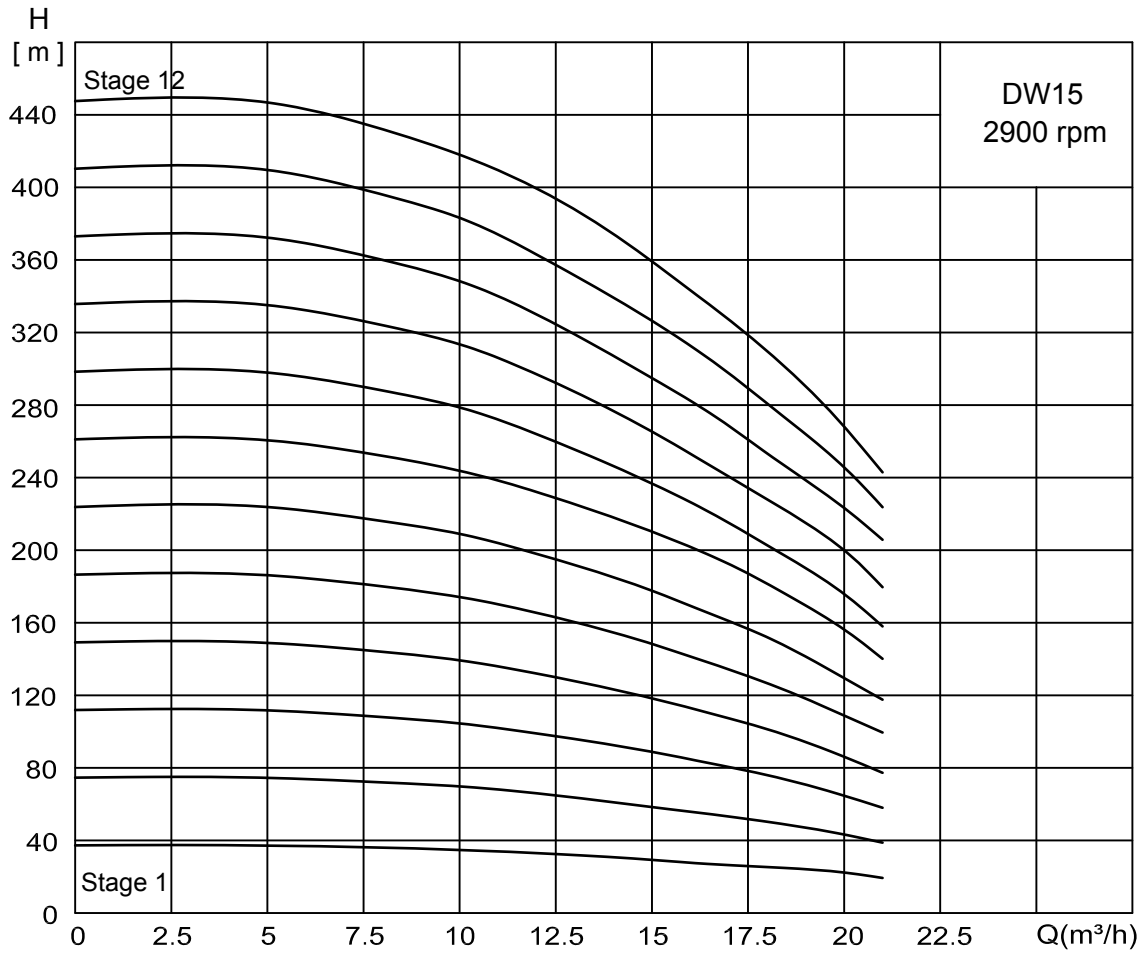

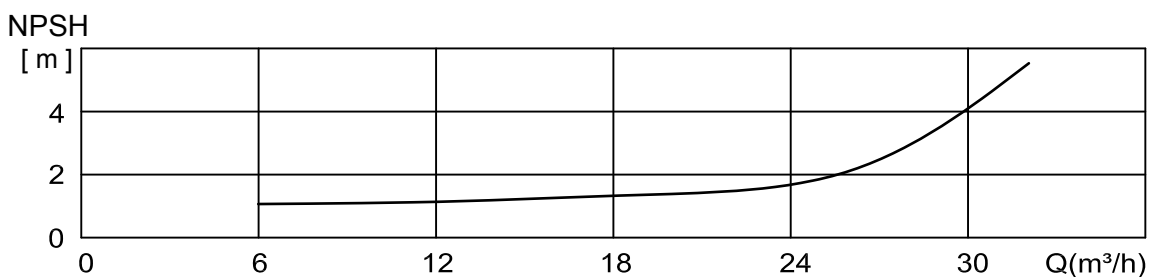
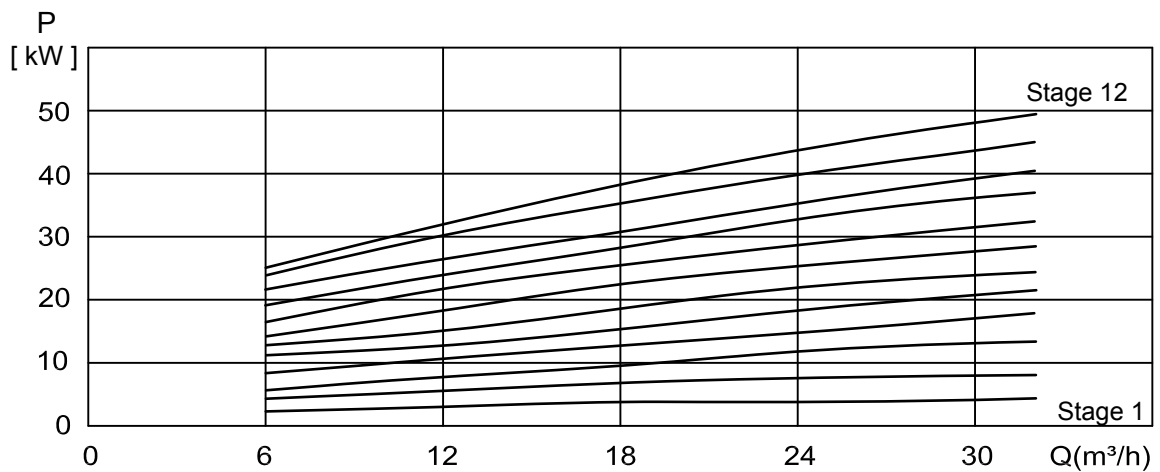
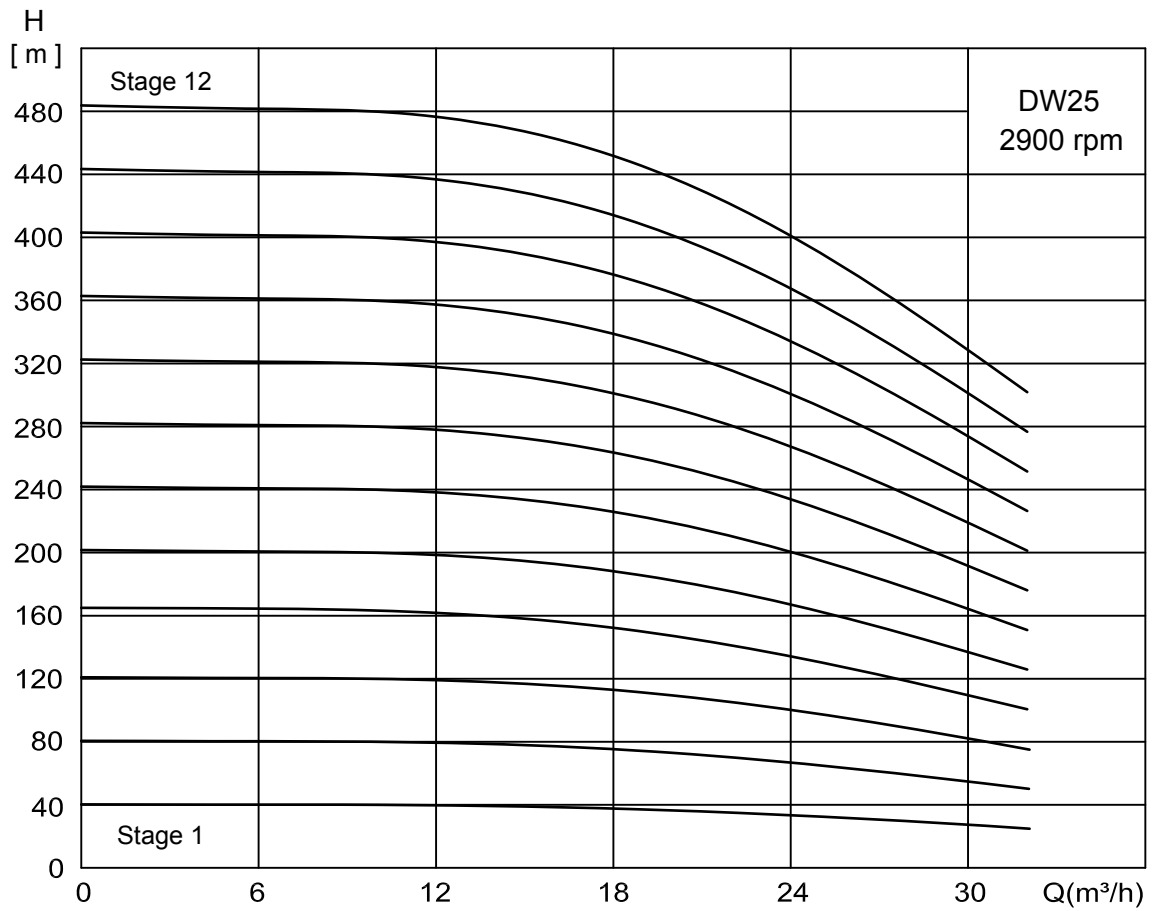

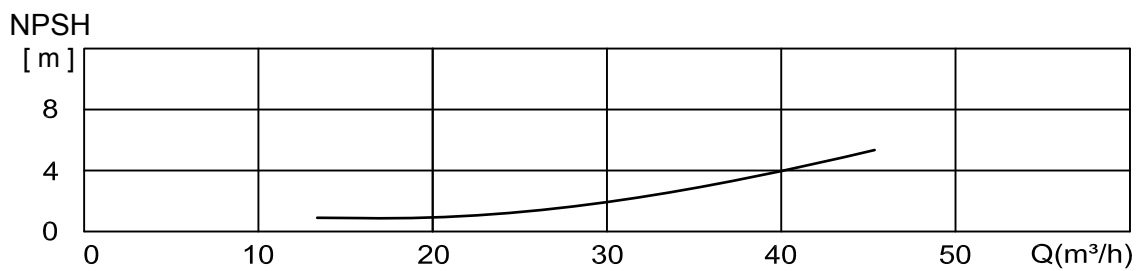
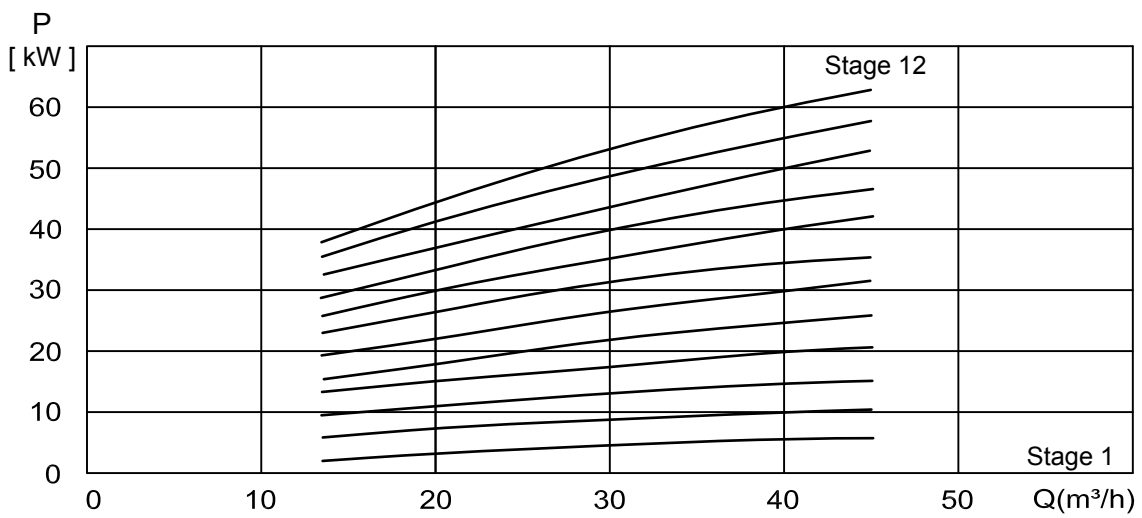
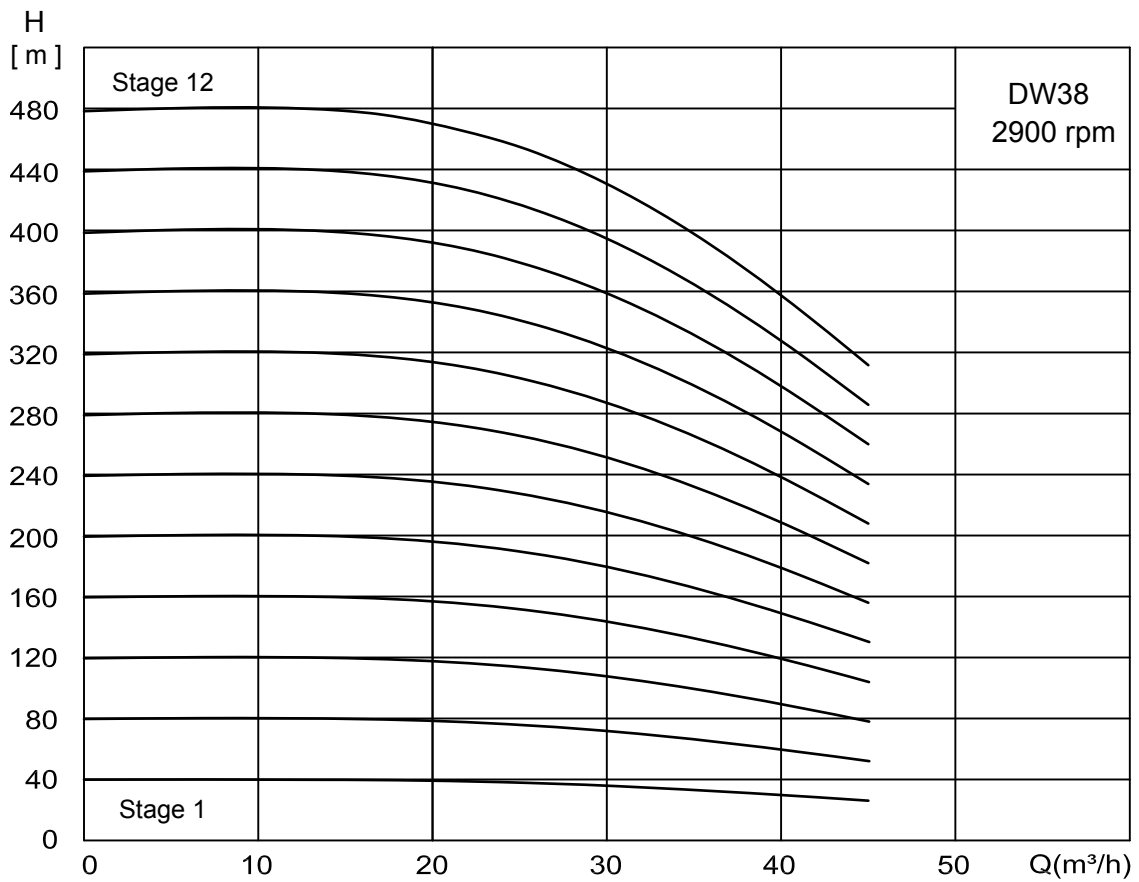

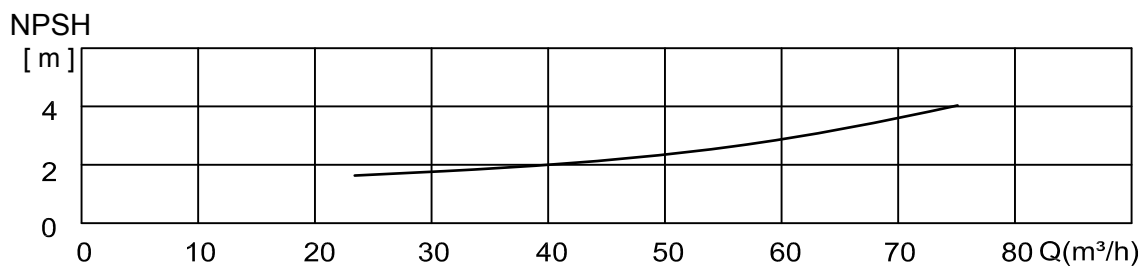
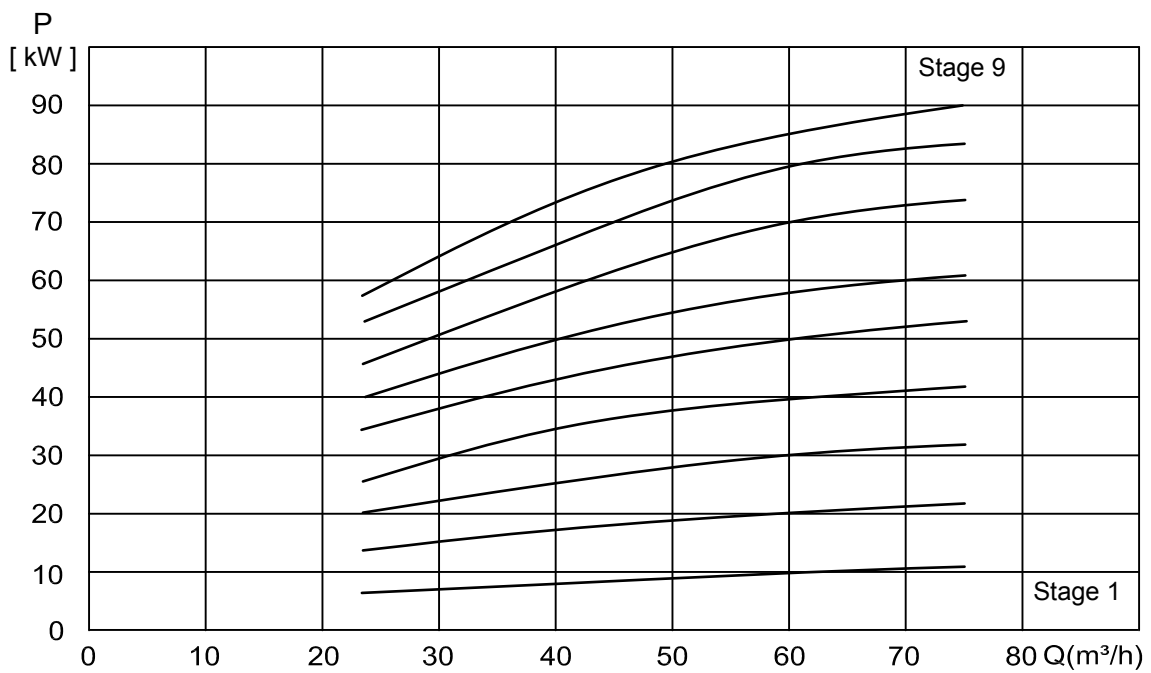
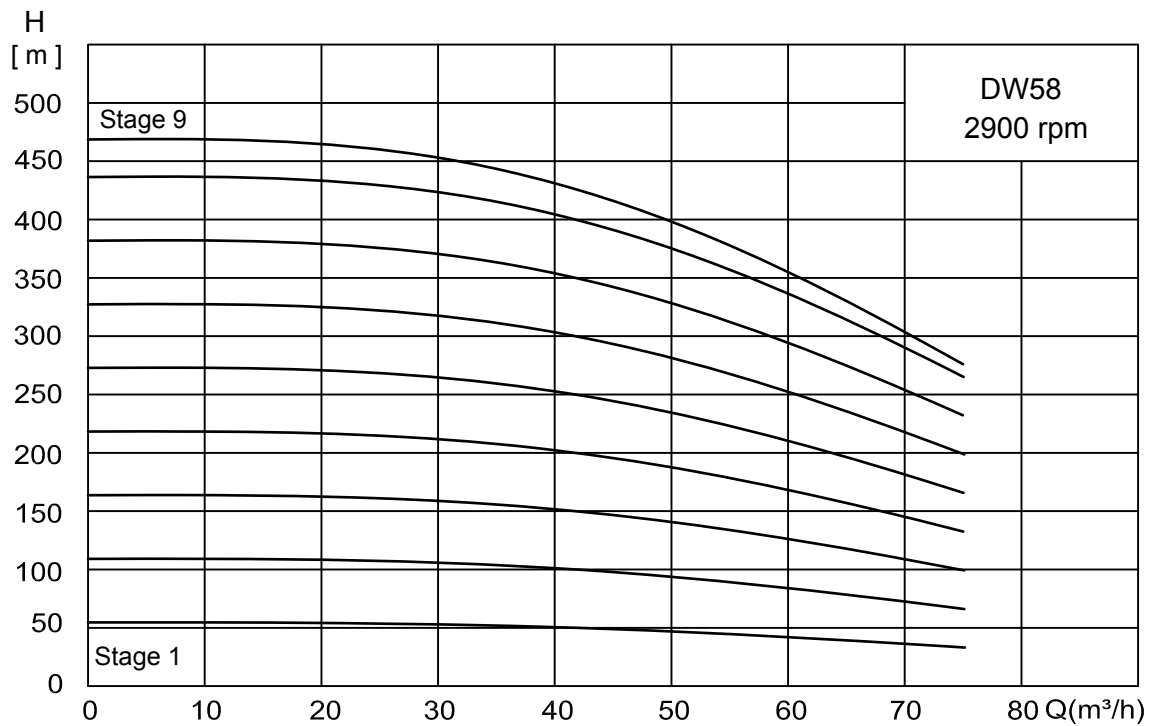

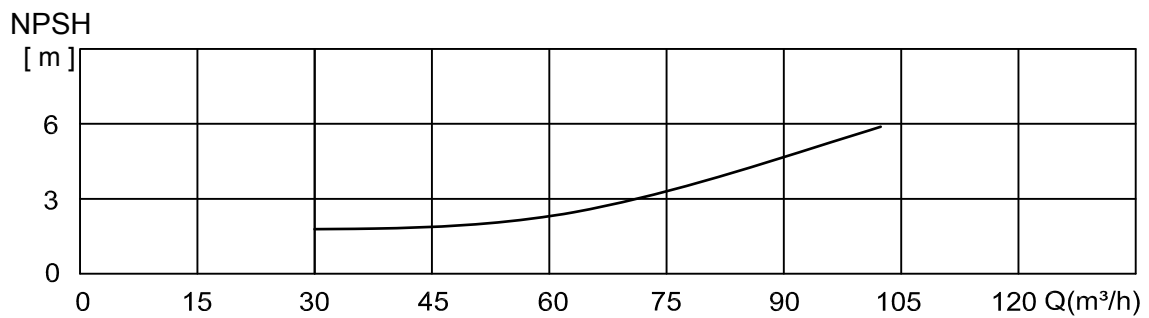
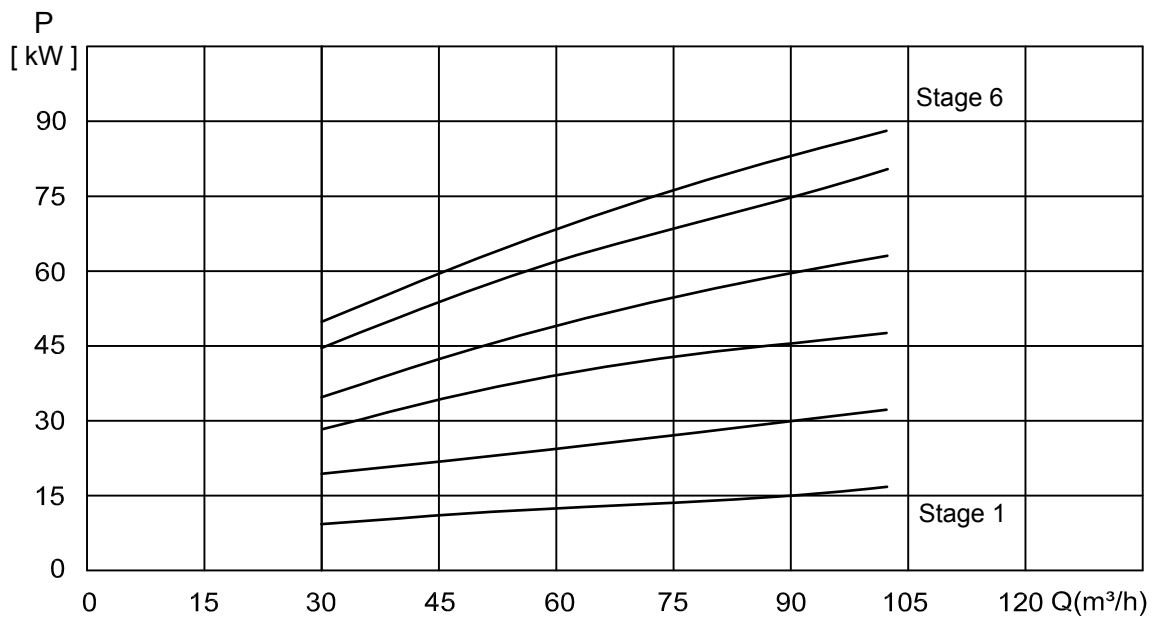
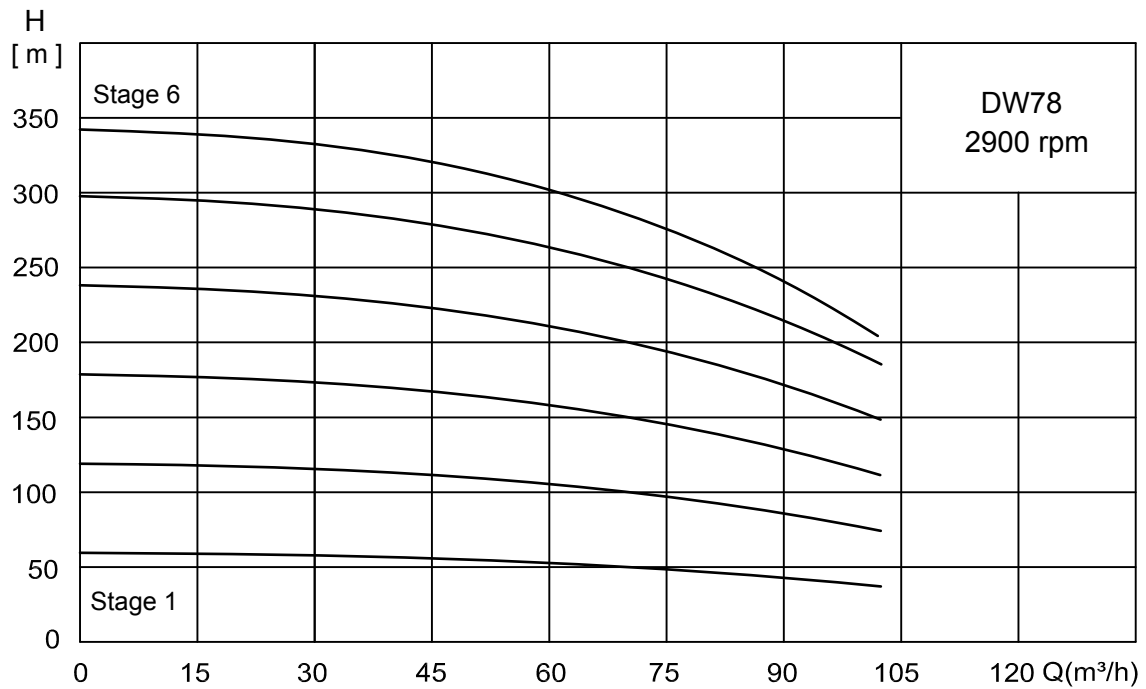

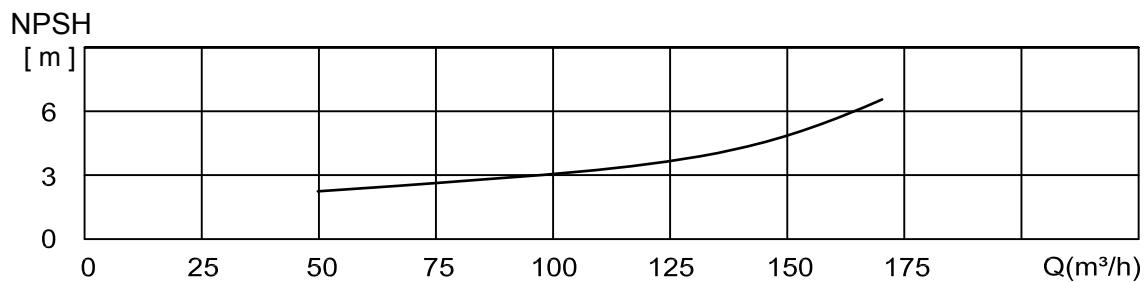
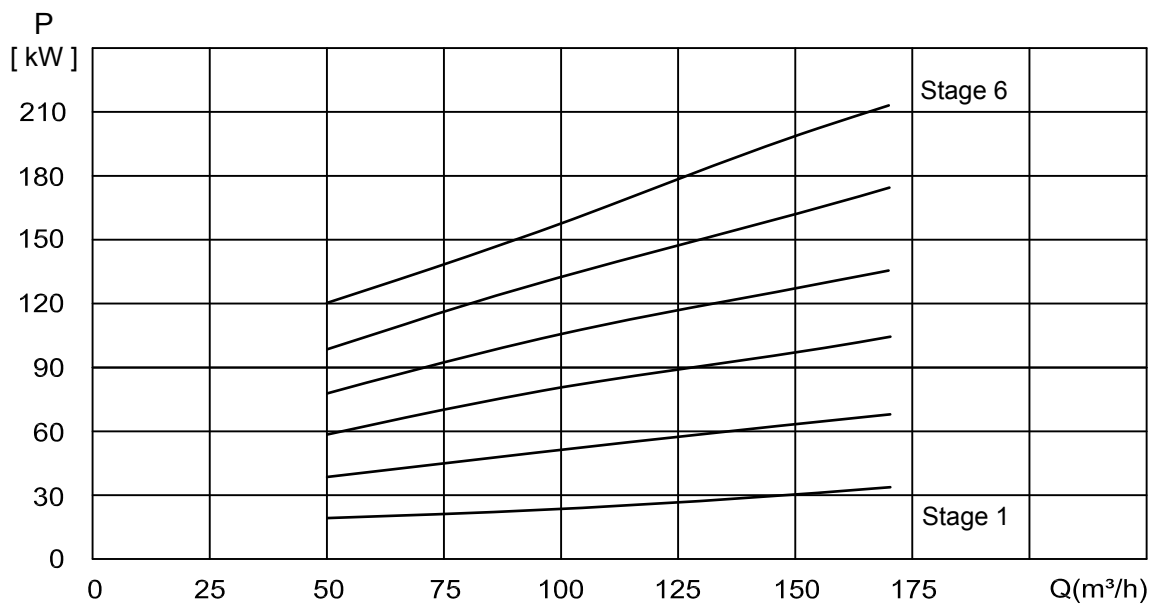
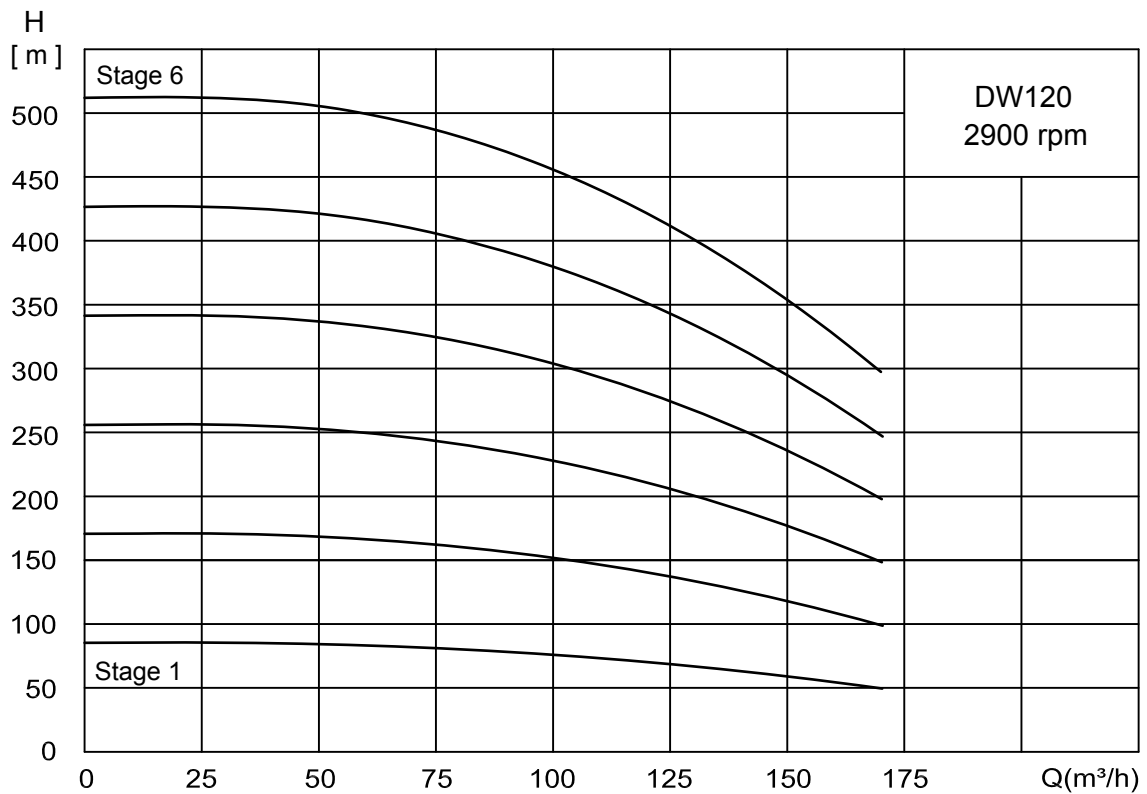

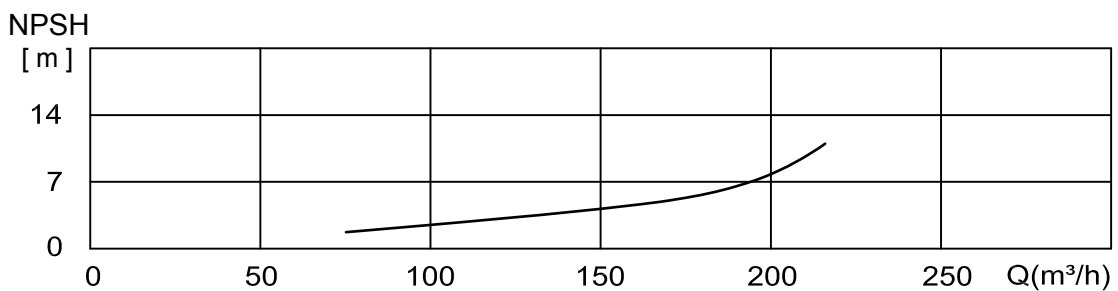
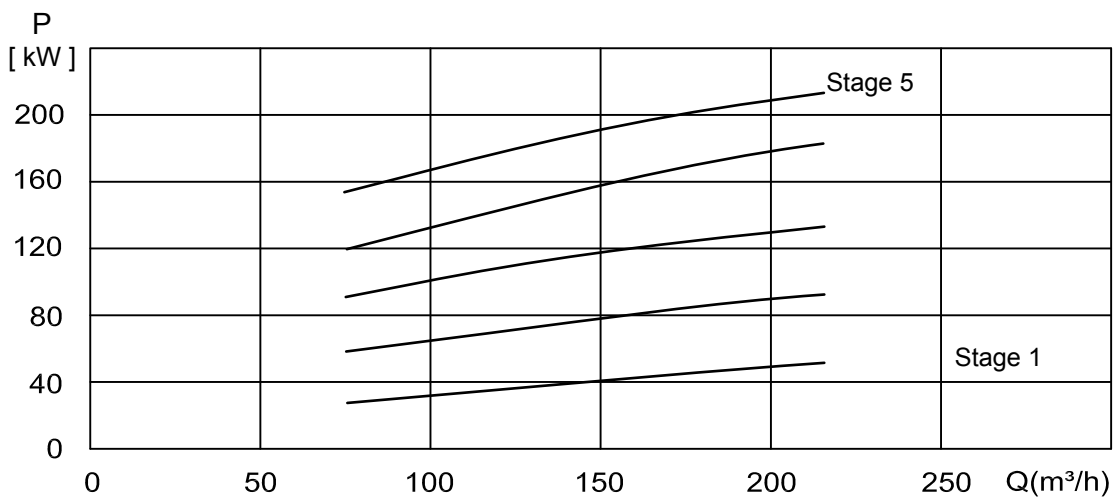
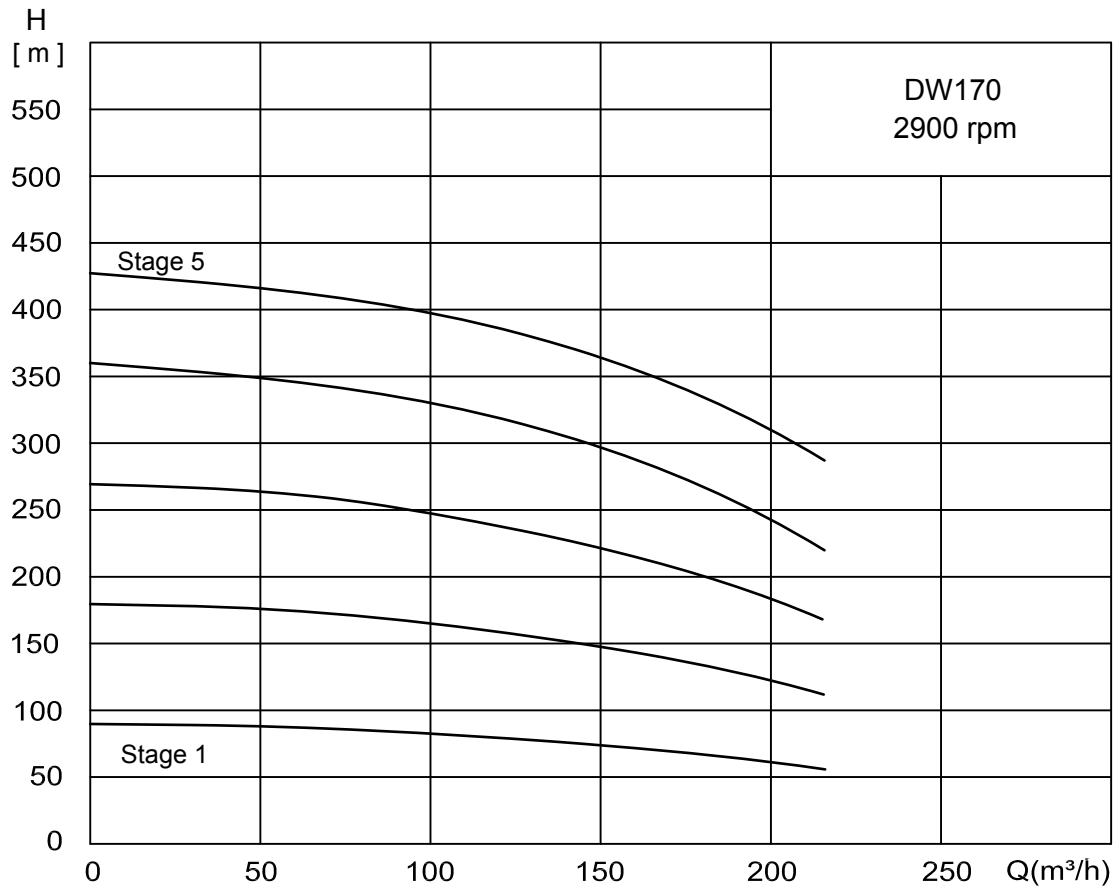

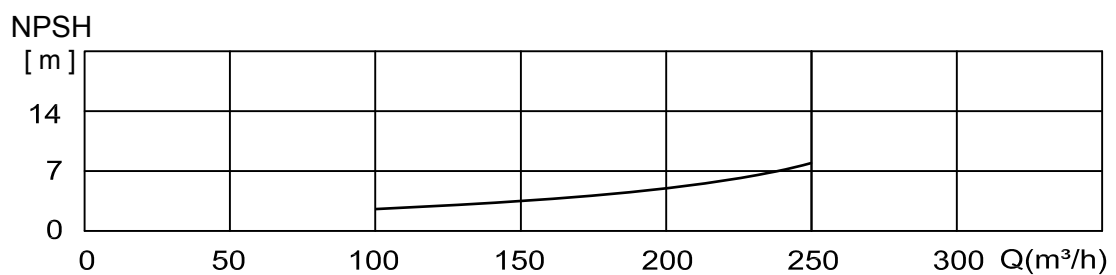
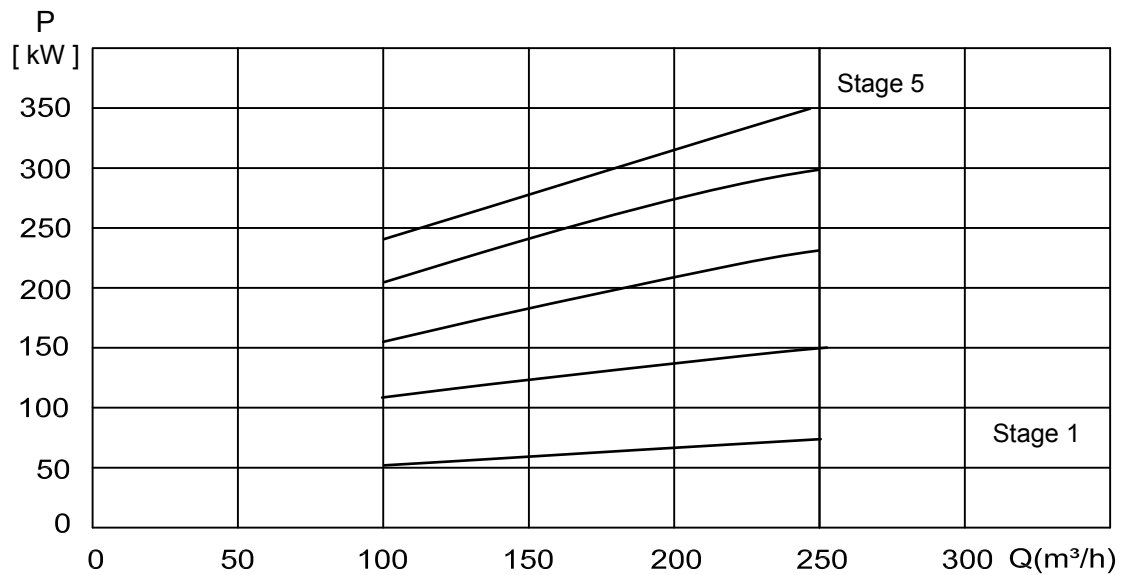
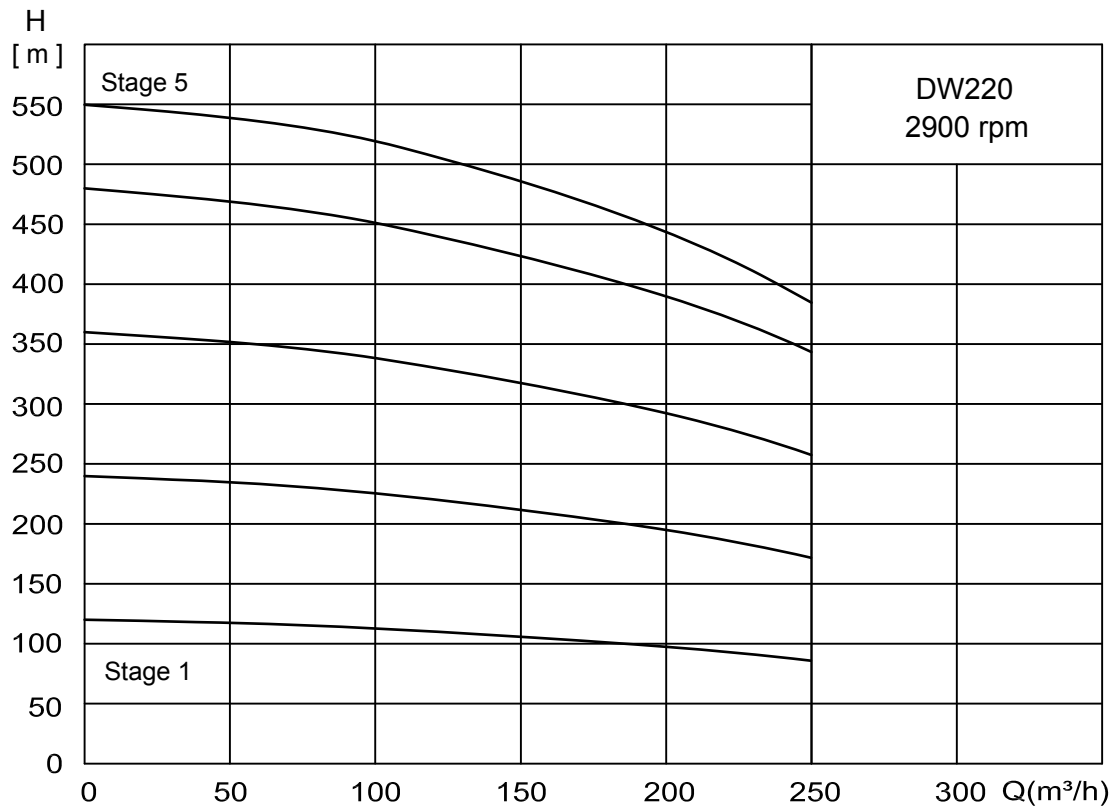

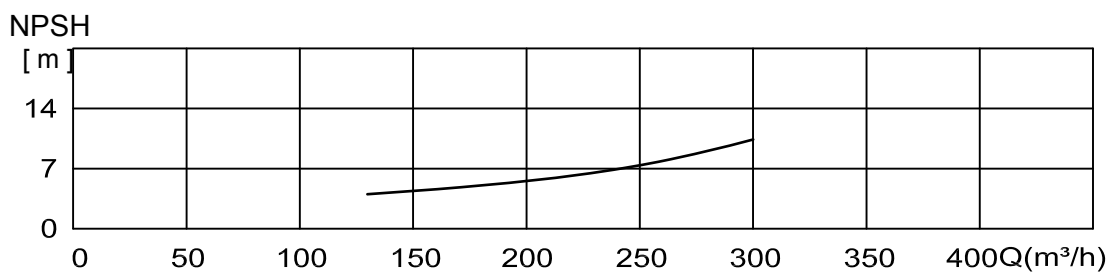
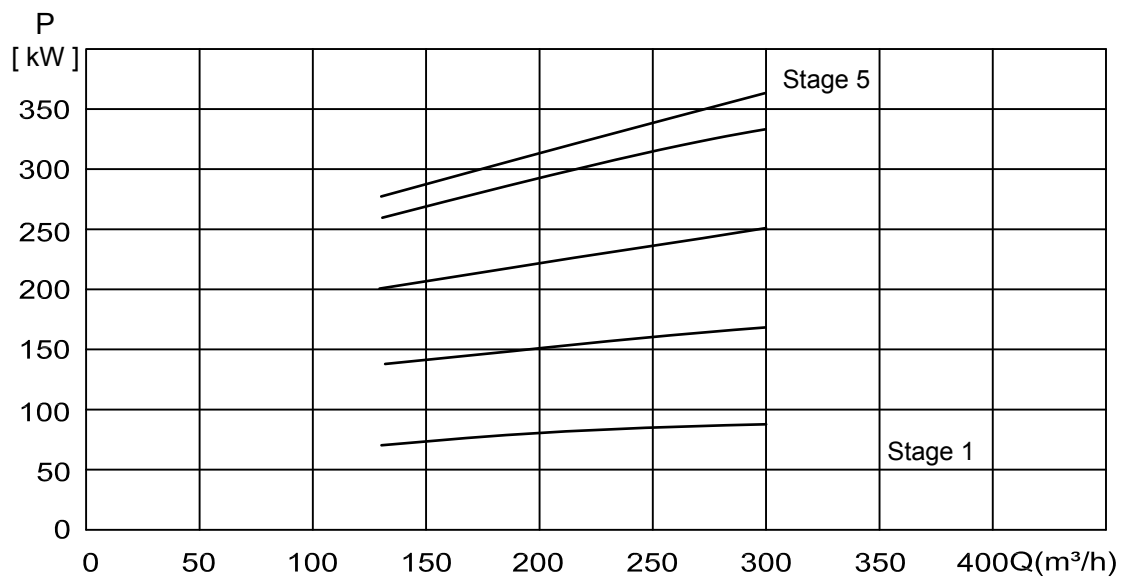
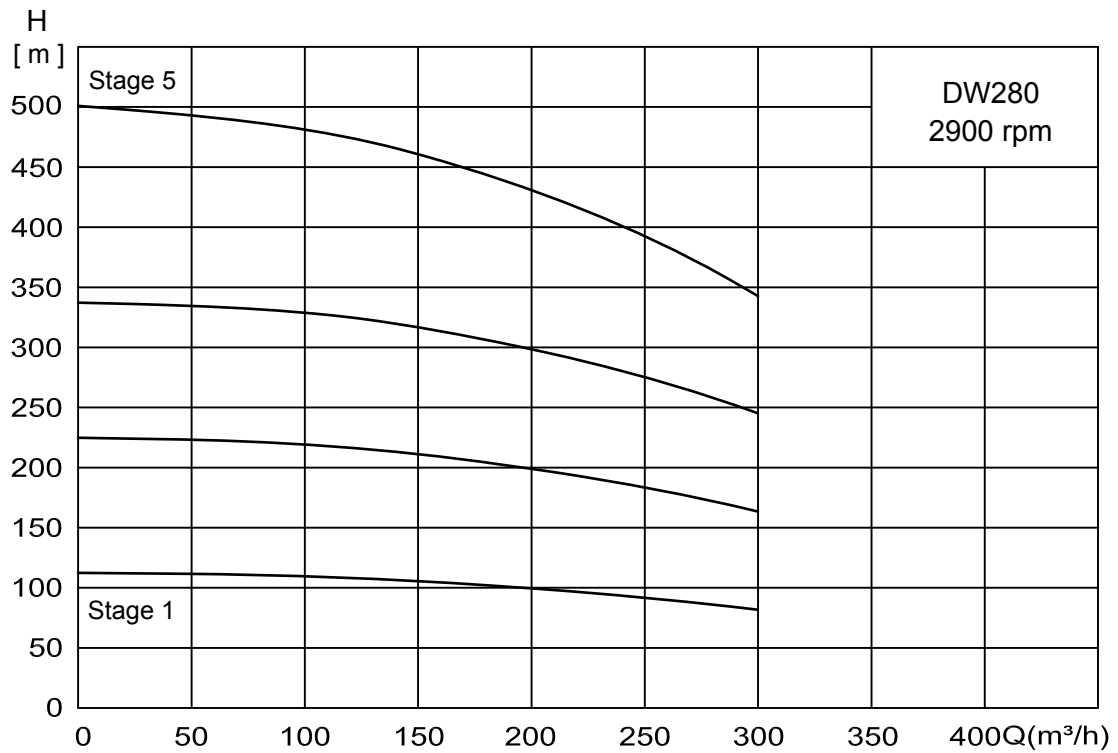

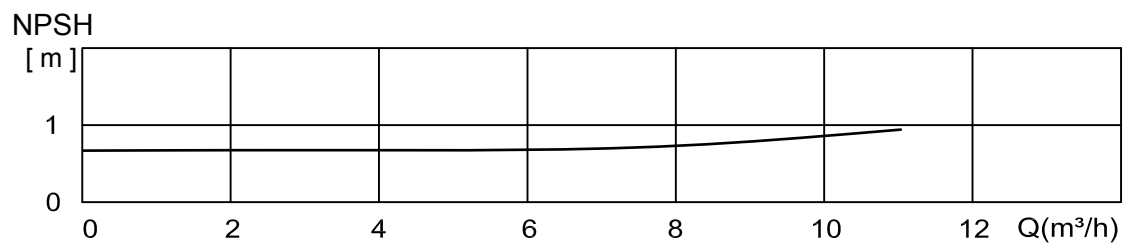
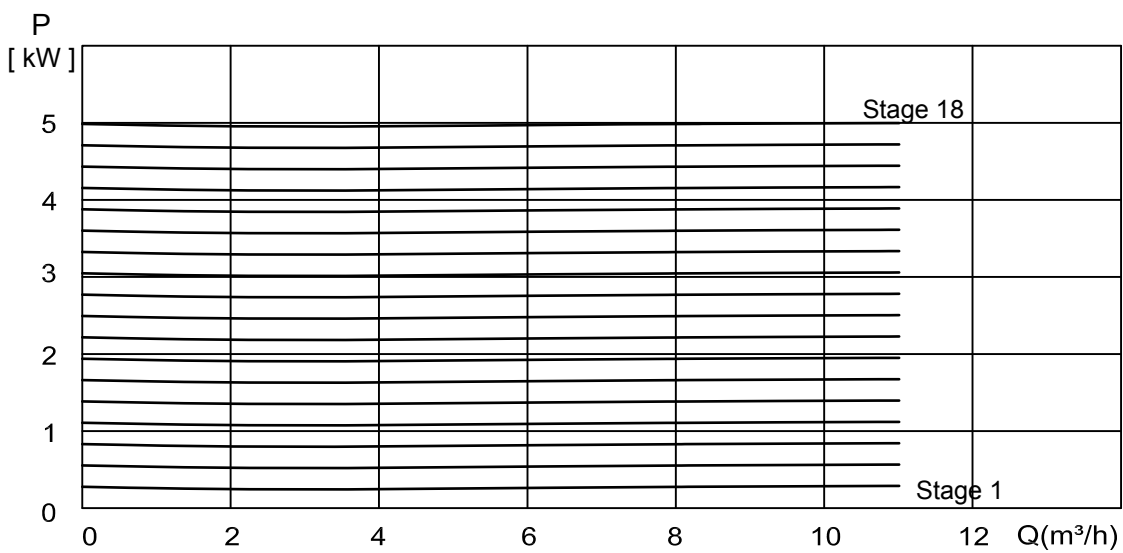
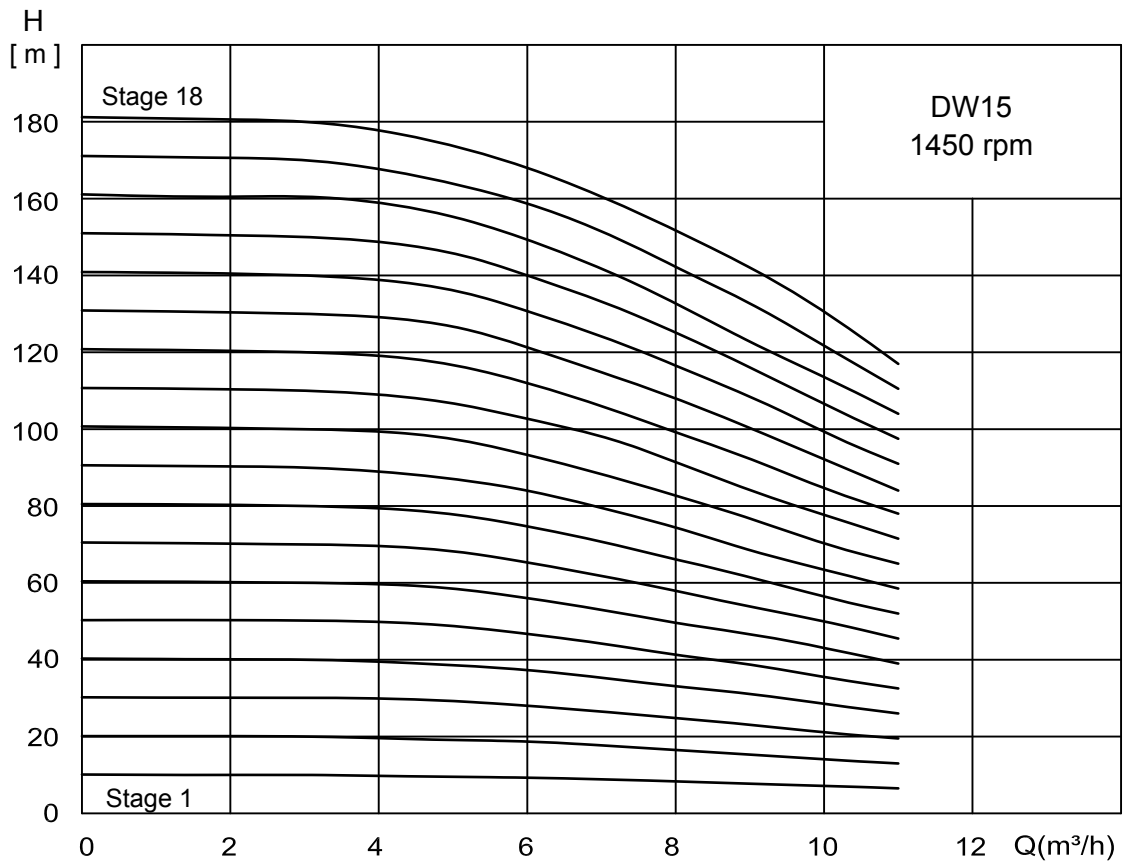

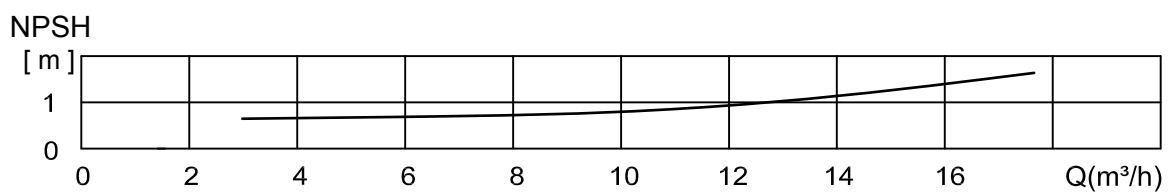
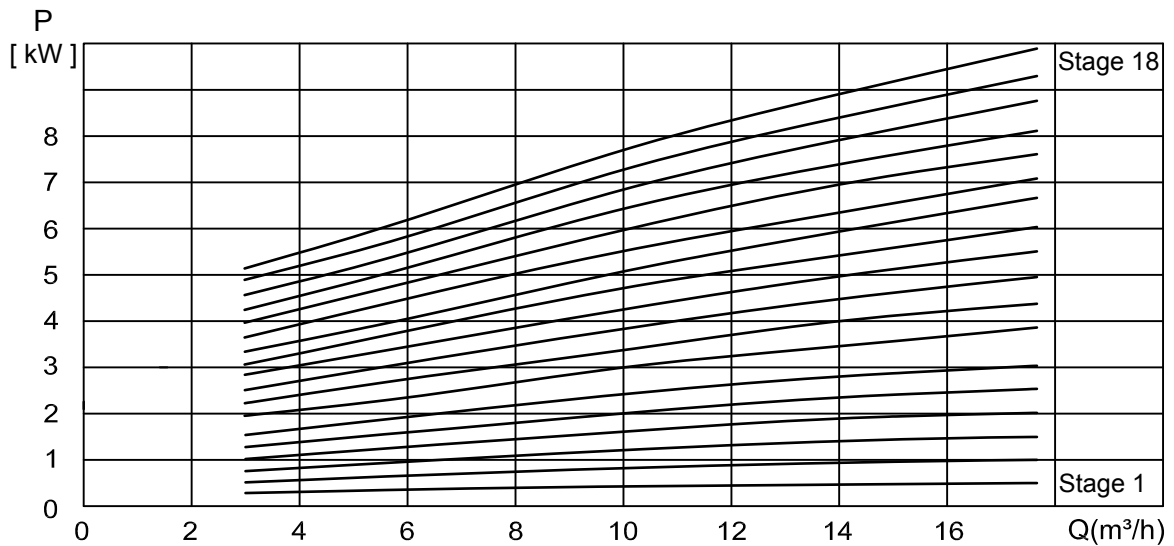
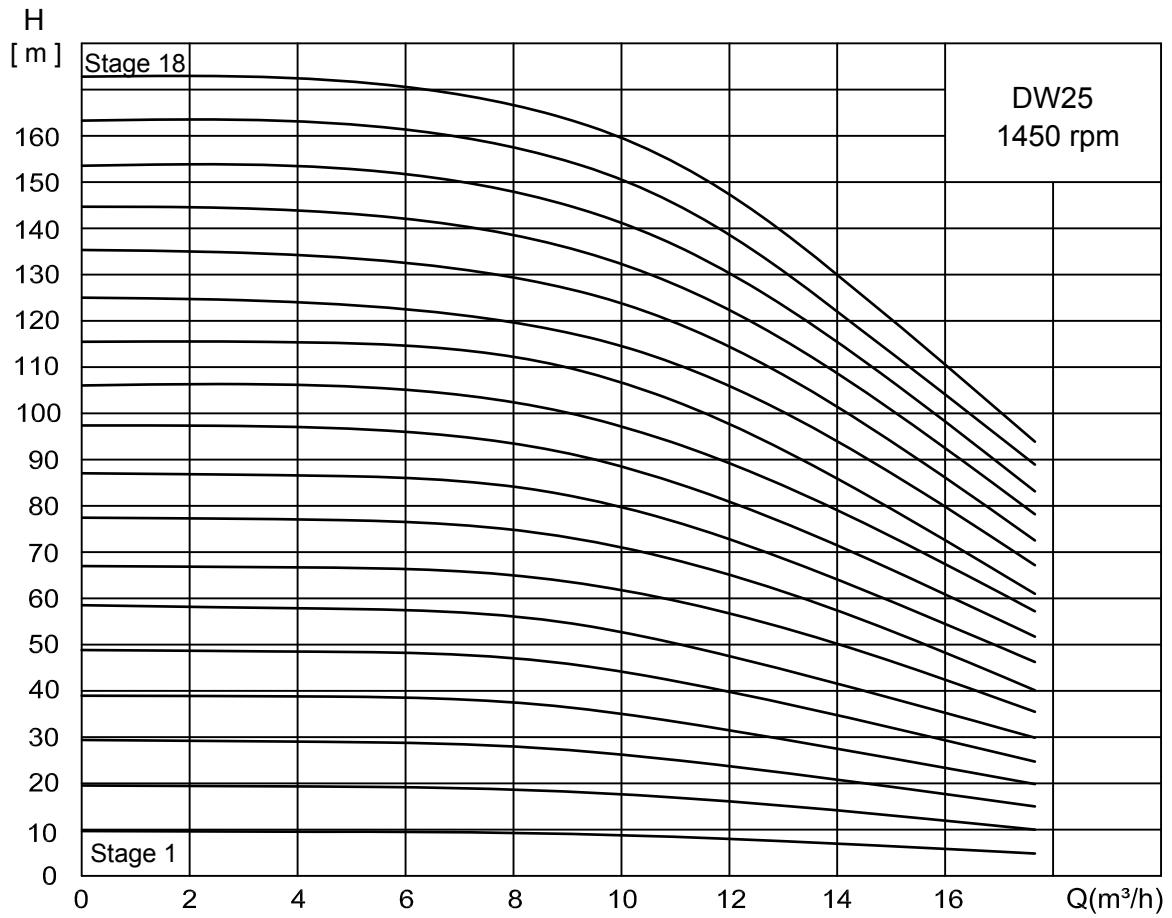

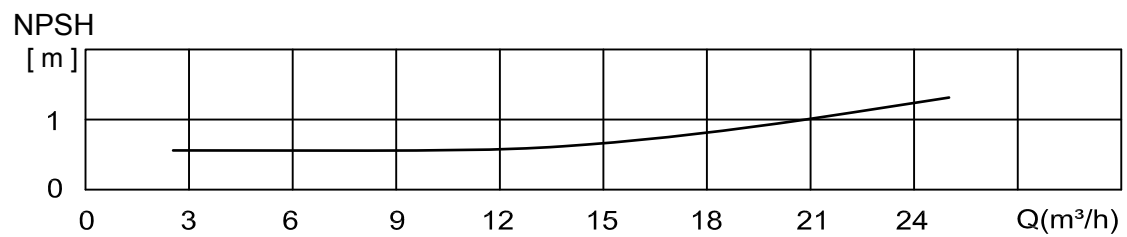
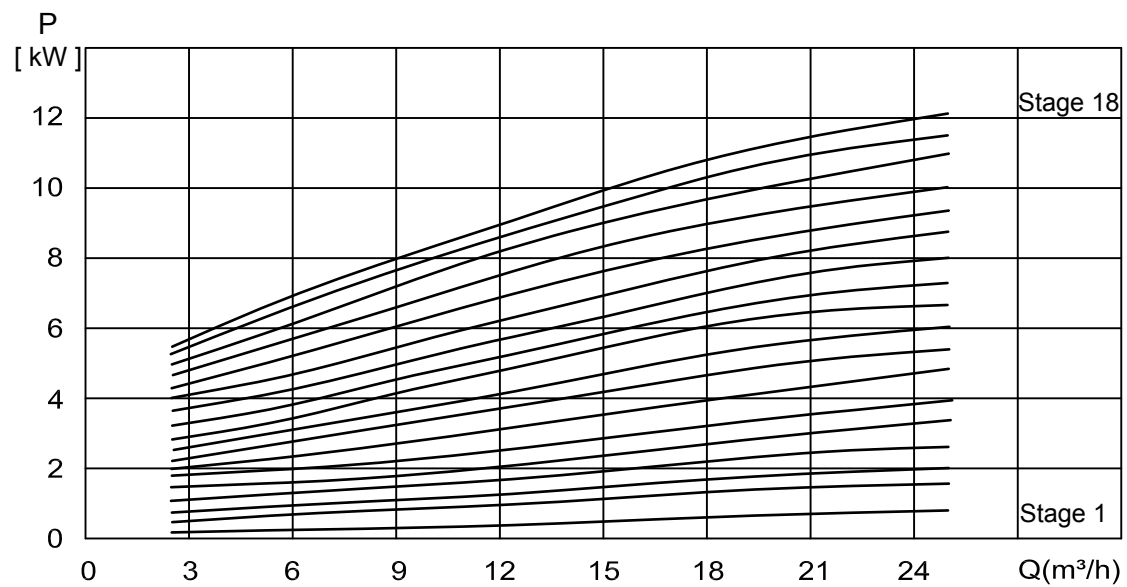
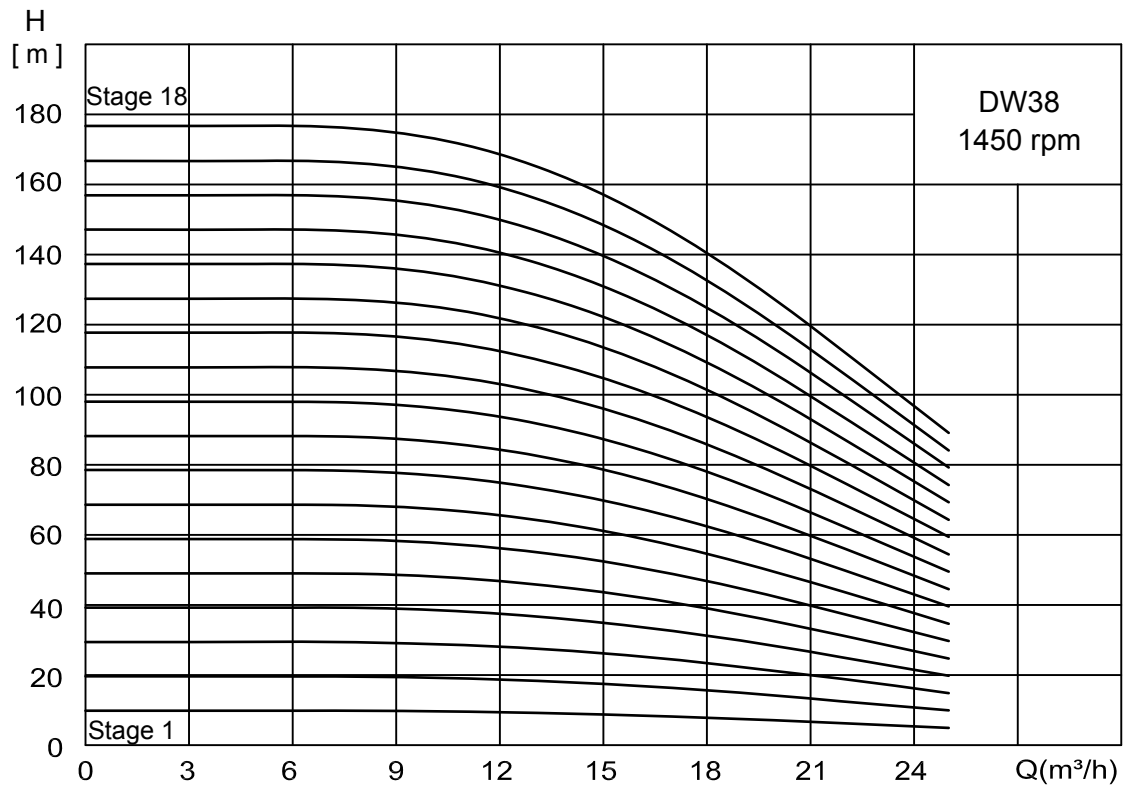

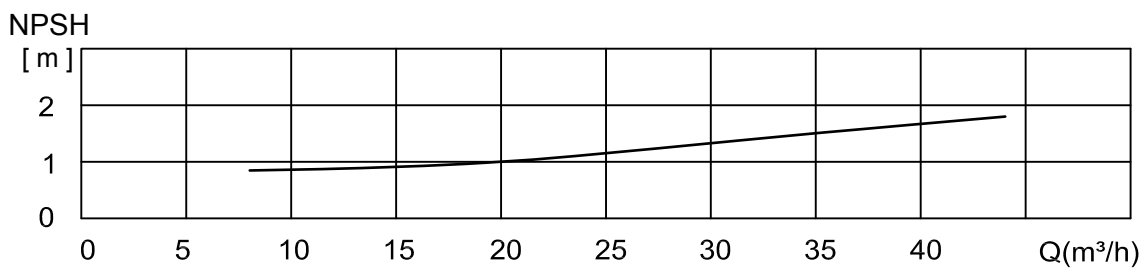
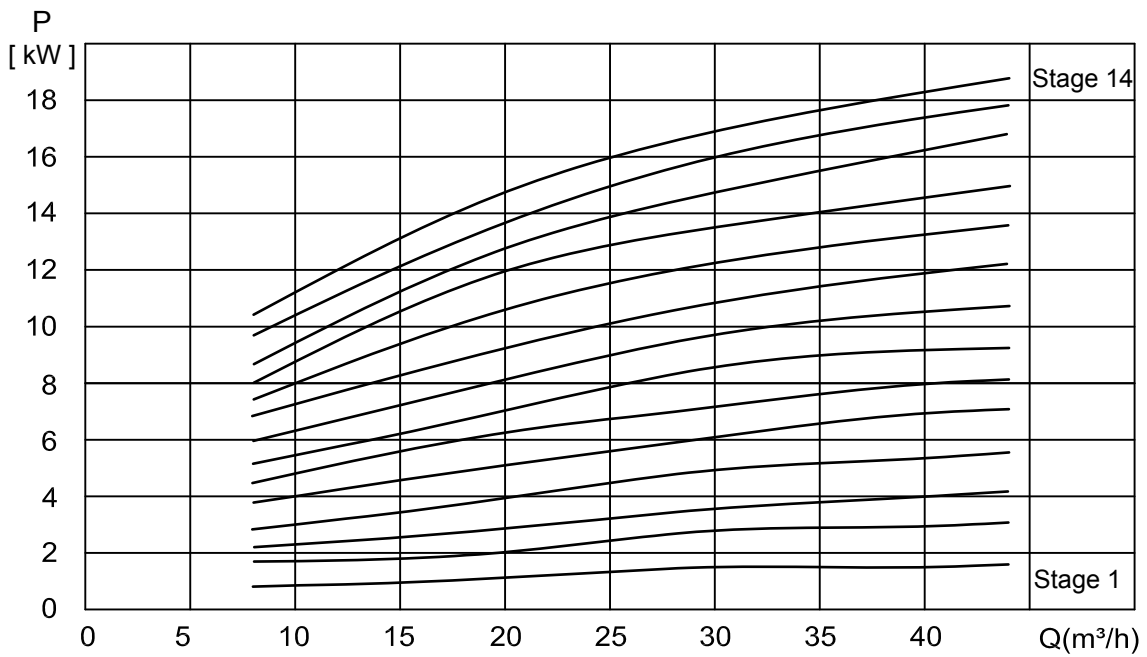
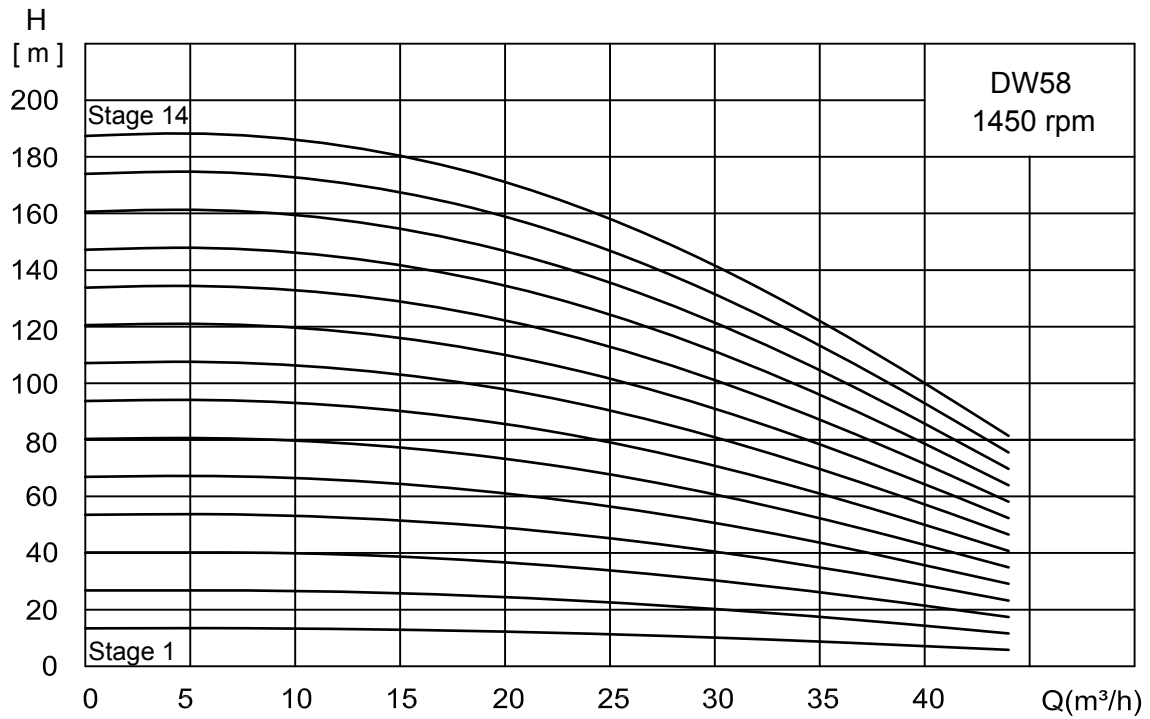

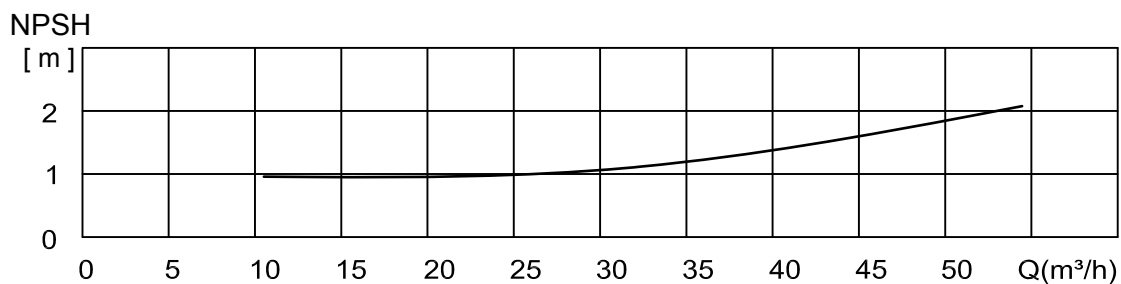
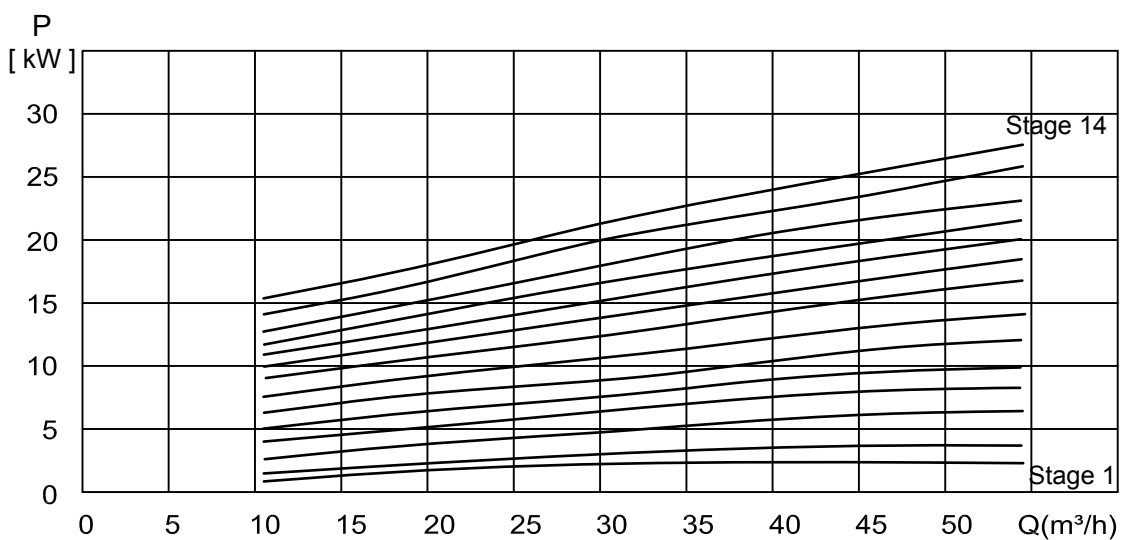
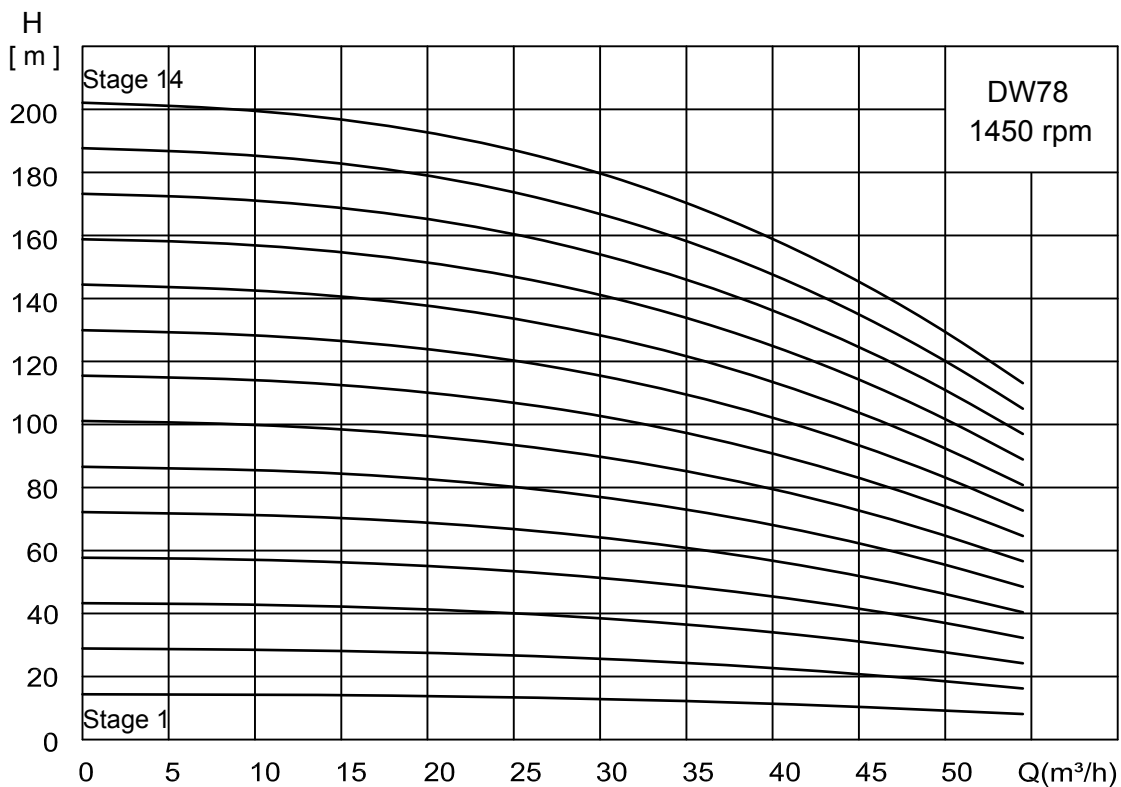

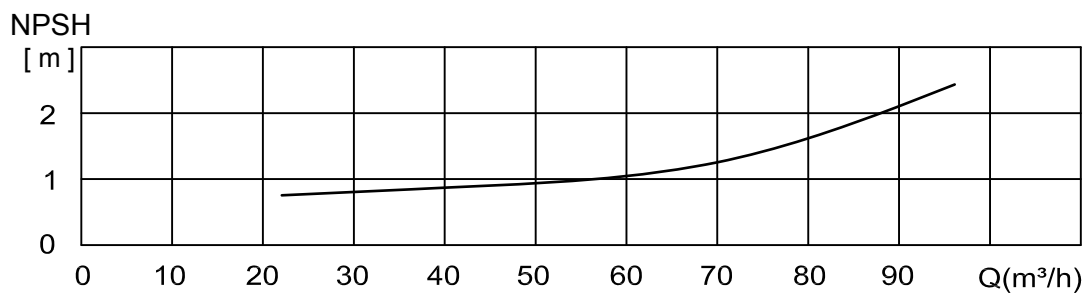
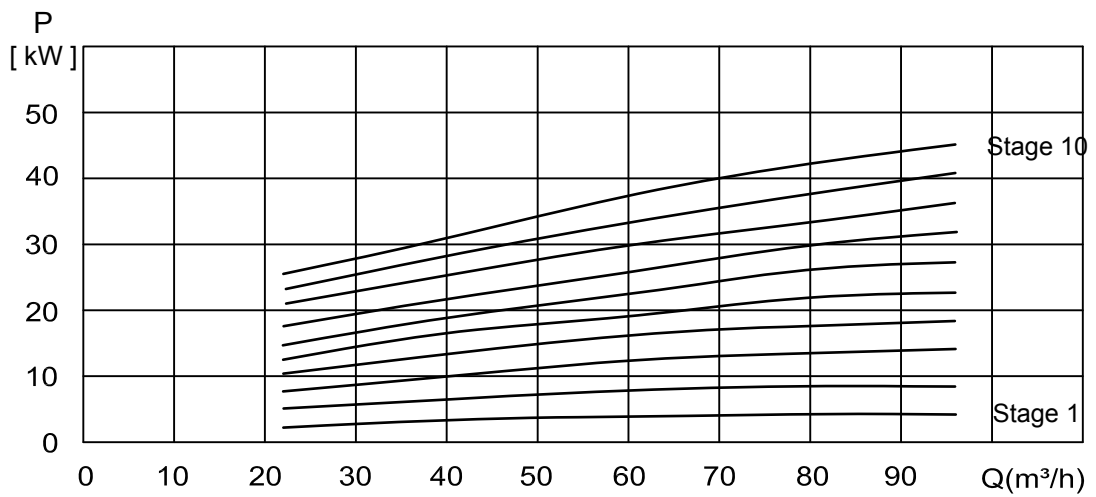
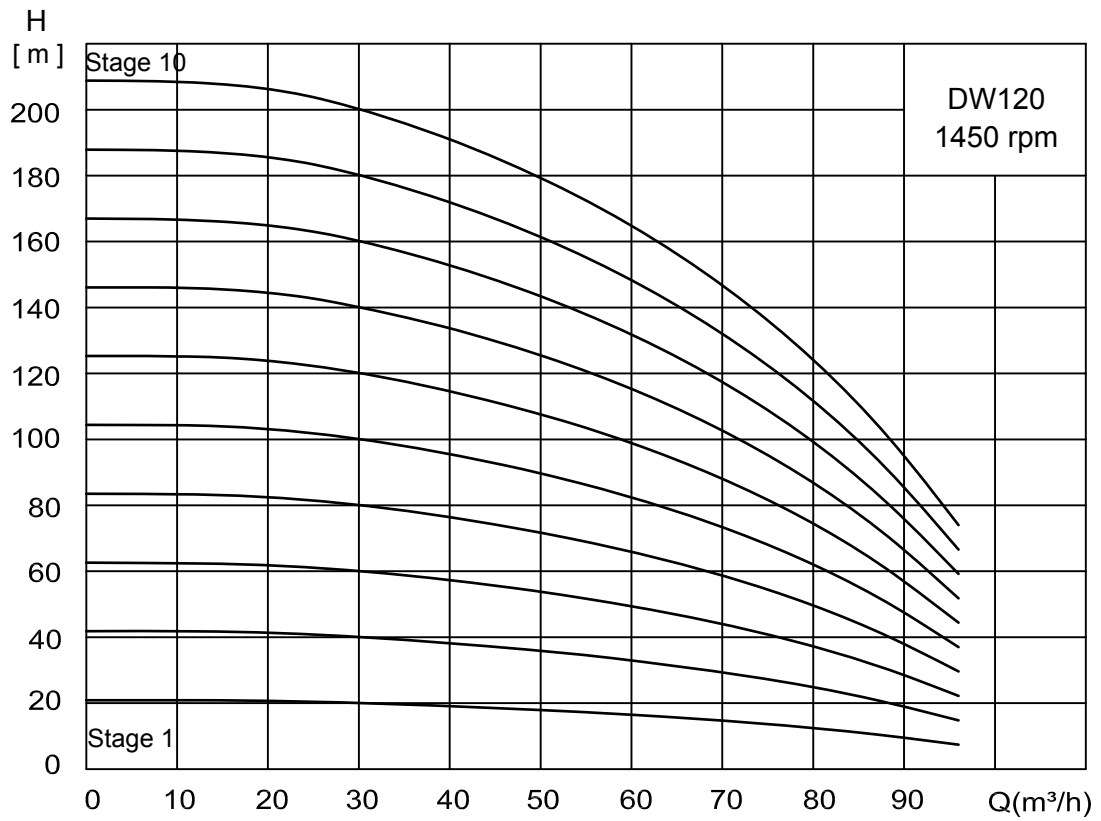

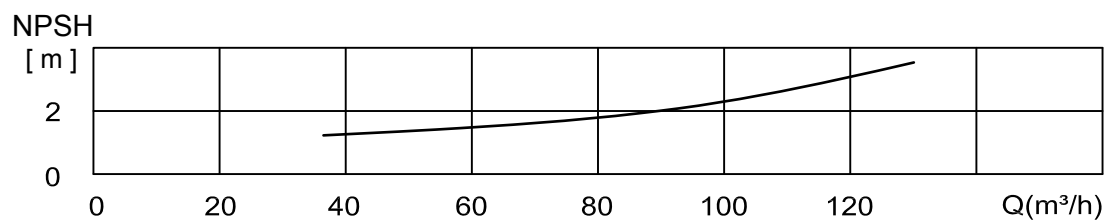
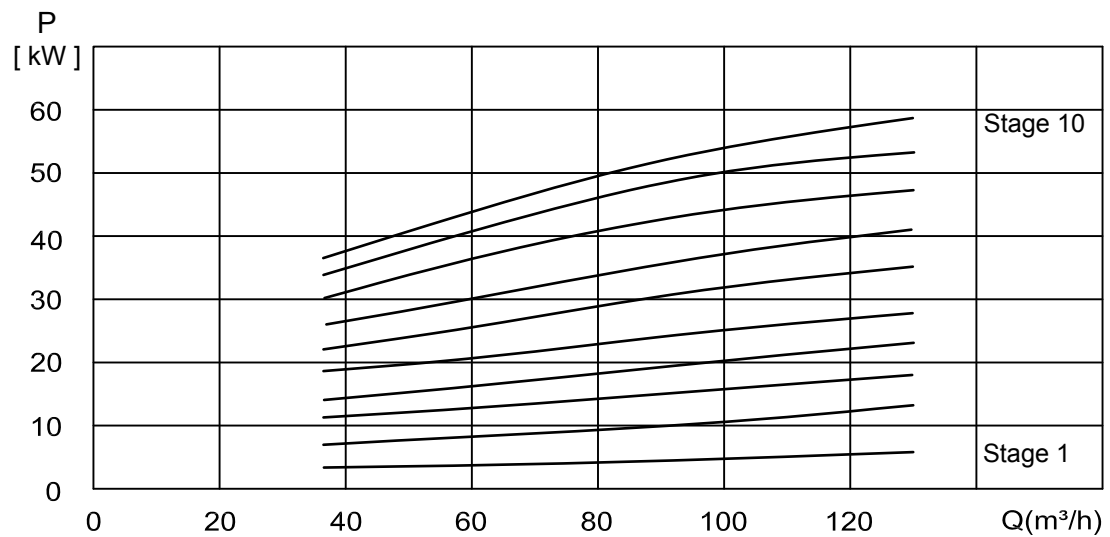
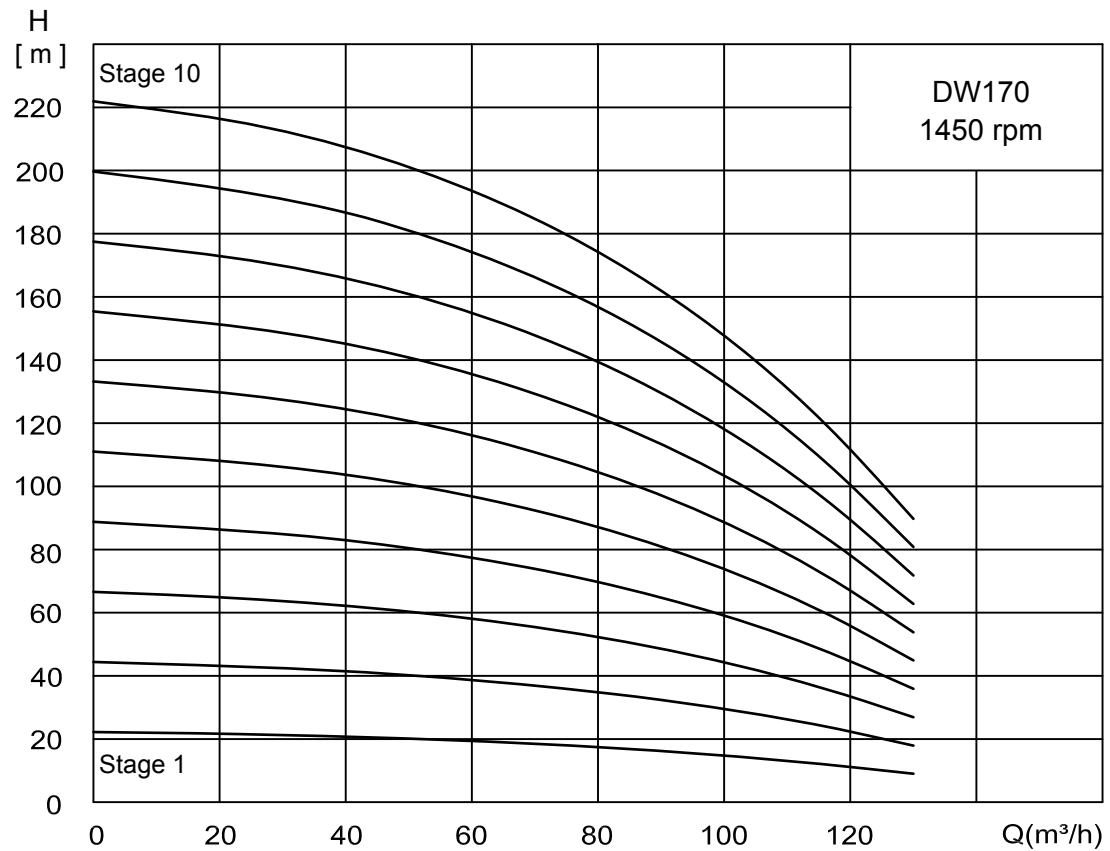

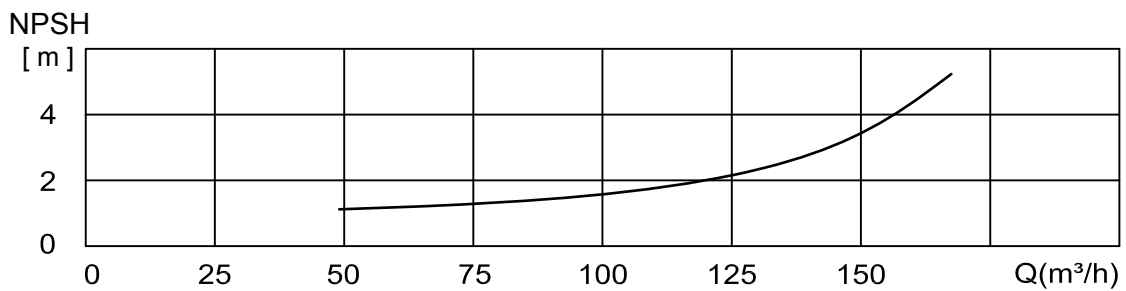
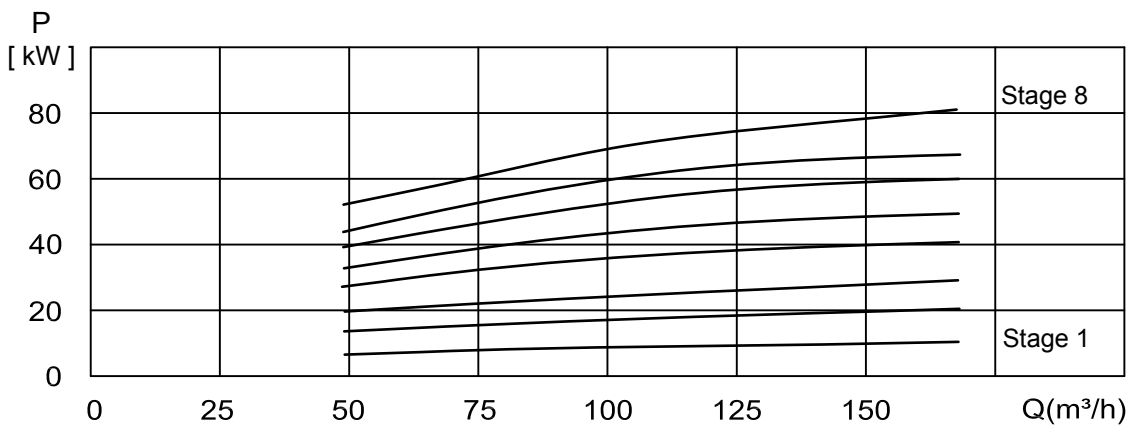
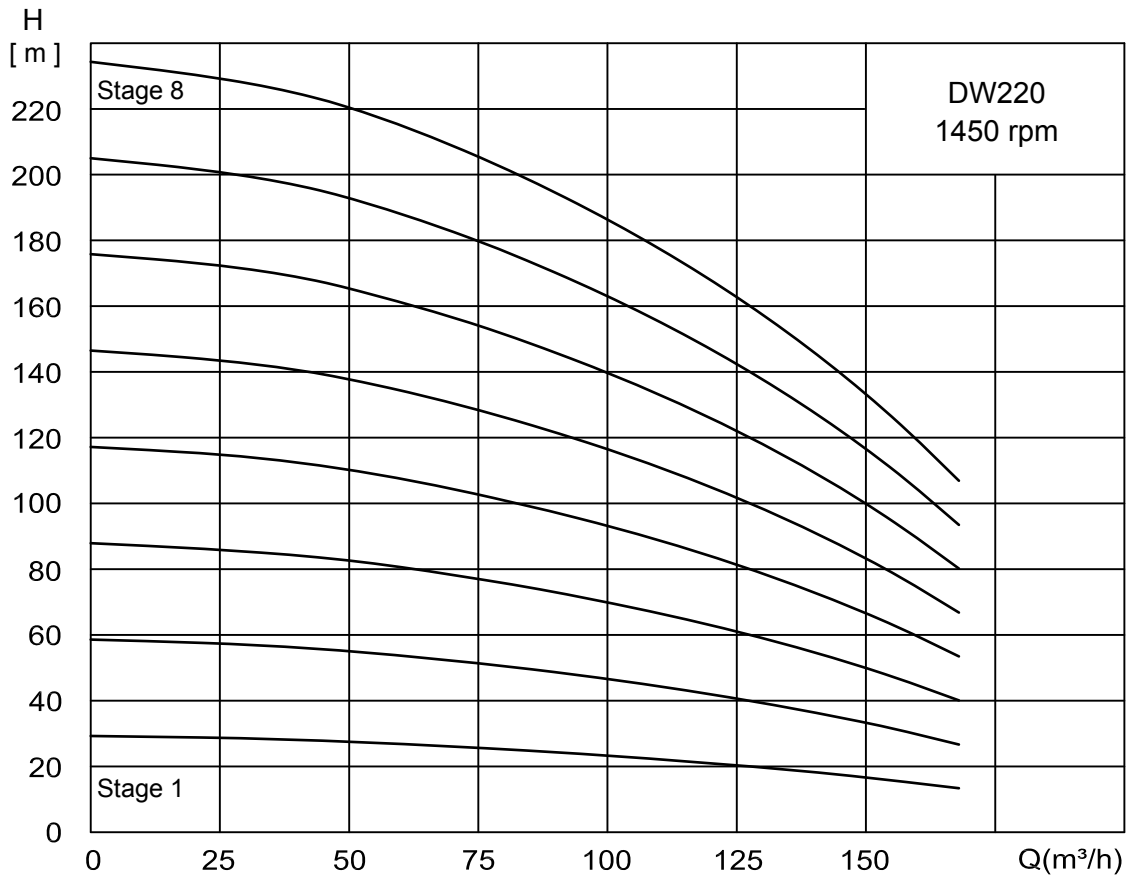

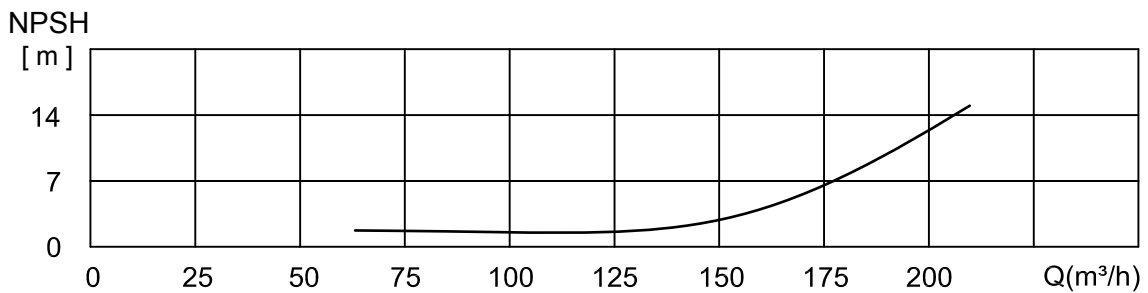
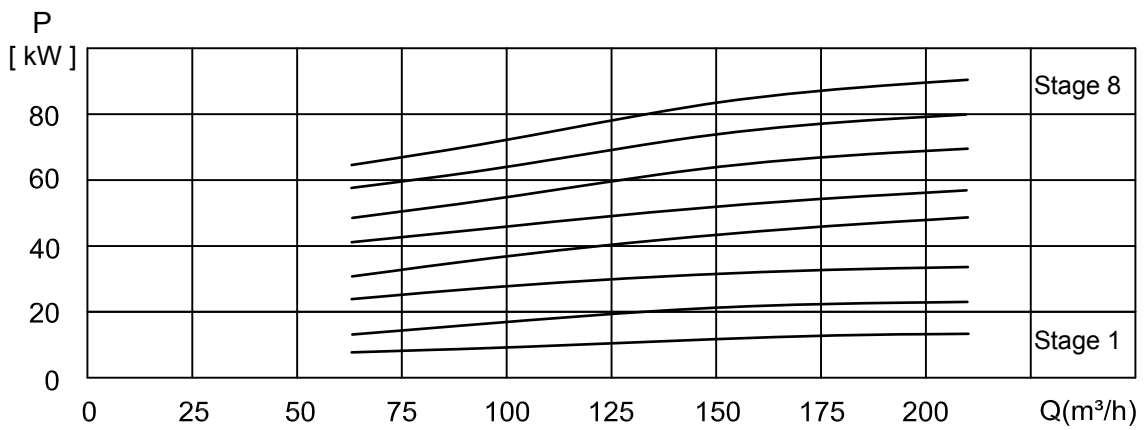
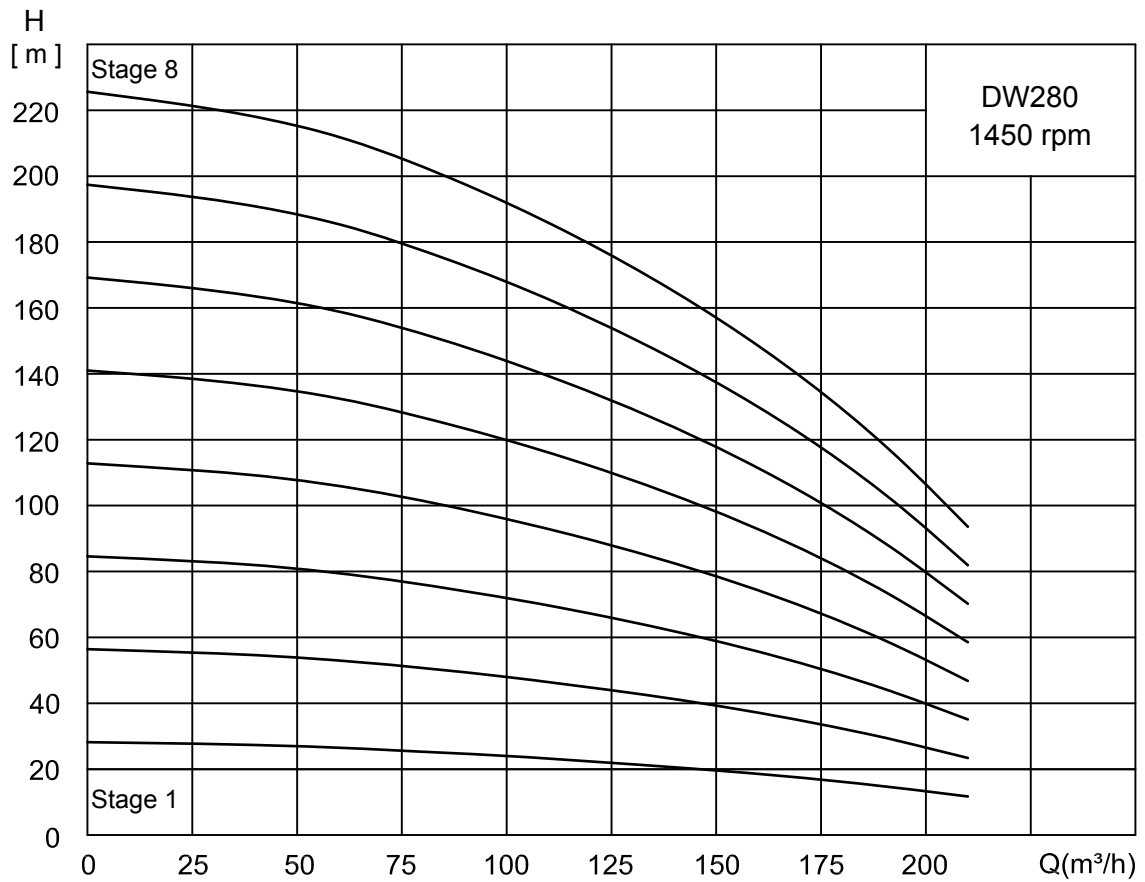

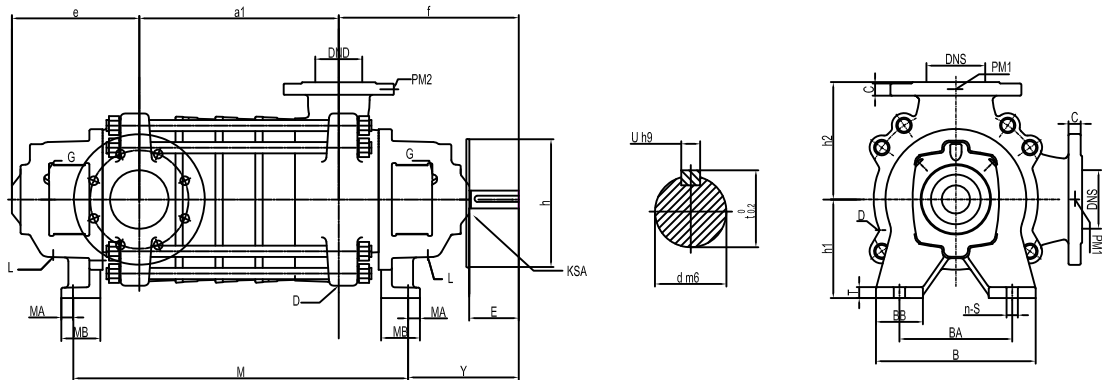

Pump model	Pump Flange		Pump dimension												Pump shaft end			
	DNs	DNd	B	BA	BB	T	e	f	h	h1	h2	MA	MB	Y	d	t	u	E
DW16	40	25	230	160	70	20	203	280	190	140	180	20	60	187	28	31	8	75
DW25 38	65	40	230	160	70	20	203	280	190	140	180	20	60	187	28	31	8	75
DW58 78	100	65	250	180	70	20	230	315	190	160	210	25	67	207	32	35	10	80
DW120 170	125	100	340	240	100	25	271	370	230	210	250	25	83	222	38	41	10	90
DW220 280	150	125	400	280	120	25	335	450	310	250	300	25	90	280	48	51.5	14	105

Pump model		no of stage																	
		1	2	3	4	5	6	7	8	9	10	11	12	13	14	15	16	17	18
DW16 25 38	a1	90	145	200	255	310	365	420	475	530	585	640	695	750	805	860	915	970	1025
	M	274	329	384	439	494	549	604	659	714	769	824	879	934	989	1044	1099	1154	1209
DW58 78	a1	110	180	250	320	390	460	530	600	670	740	810	880	950	1020	-	-	-	-
	M	321	391	461	531	601	671	741	811	881	951	1021	1091	1161	1231	-	-	-	-
DW120 170	a1	170	255	340	425	510	595	680	765	850	935	-	-	-	-	-	-	-	-
	M	459	544	629	714	799	884	969	1054	1139	1224	-	-	-	-	-	-	-	-
DW220 280	a1	210	315	420	525	630	735	840	945	-	-	-	-	-	-	-	-	-	-
	M	543	648	753	858	963	1068	1173	1278	-	-	-	-	-	-	-	-	-	-

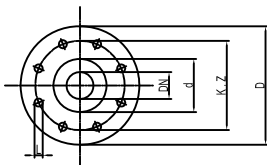

DN	PN	D	K	C	d	L	Z
25	25/40	115	85	16	25	16	4
40	25/40	156	110	22	84	19	4
65	25/40	191	145	24	118	19	8
100	25/40	235	190	27	156	23	8
125	25/40	279	220	29	184	28	8
150	25/40	300	250	32	211	28	8

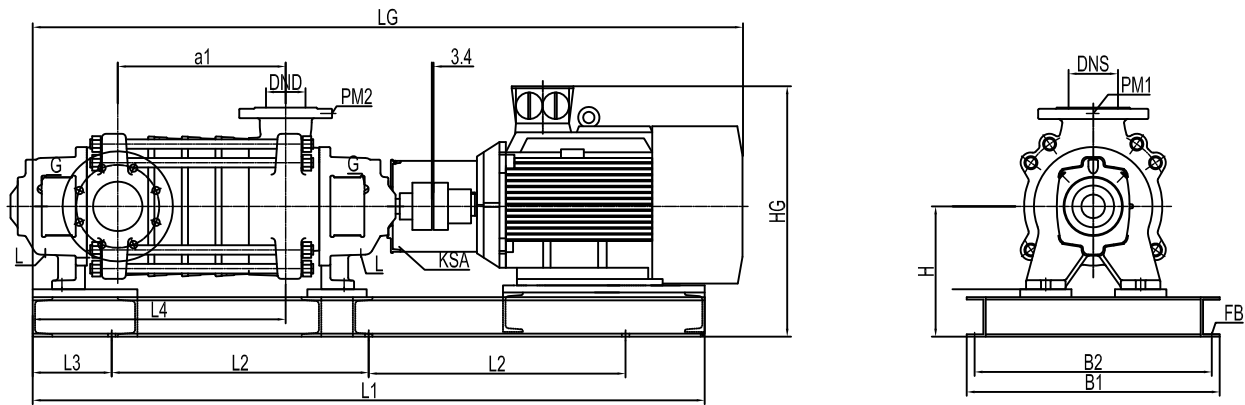

型号	转速	功率	DNS	DND	a1	B1	B2	H	L1	L2	L3	L4	BG	HG	LG	FB
DW16-1	2900	11	40	25	90	540	500	281	1250	500	125	352	550	500	1275	6XM16
DW16-2	2900	15	40	25	145	540	500	281	1250	500	125	352	550	500	1275	6XM16
DW16-3	2900	18.5	40	25	200	540	500	281	1250	500	125	352	550	500	1370	6XM16
DW16-4	2900	30	40	25	255	640	600	321	1400	550	150	462	685	630	1565	6XM16
DW16-5	2900	30	40	25	310	640	600	321	1400	550	150	462	685	630	1615	6XM16
DW16-6	2900	37	40	25	365	640	600	321	1550	600	175	627	685	630	1730	6XM16
DW16-7	2900	45	40	25	420	640	600	366	1700	650	200	682	705	695	1830	6XM16
DW16-8	2900	45	40	25	475	640	600	366	1700	650	200	682	705	695	1830	6XM16
DW16-9	2900	55	40	25	530	740	700	395	1850	700	225	737	795	750	2010	6XM16
DW16-10	2900	55	40	25	585	740	700	395	1850	700	225	737	795	750	2060	6XM16
DW16-11	2900	75	40	25	640	850	800	445	2000	750	250	847	885	905	2200	6XM20
DW16-12	2900	75	40	25	695	850	800	445	2000	750	250	847	885	905	2250	6XM20

型号	转速	功率	DNS	DND	a1	B1	B2	H	L1	L2	L3	L4	BG	HG	LG	FB
DW25-1	2900	11	65	40	90	540	500	281	1250	500	125	352	550	500	1275	6XM16
DW25-2	2900	15	65	40	145	540	500	281	1250	500	125	352	550	500	1275	6XM16
DW25-3	2900	18.5	65	40	200	540	500	281	1250	500	125	352	550	500	1370	6XM16
DW25-4	2900	30	65	40	255	640	600	321	1400	550	150	462	685	630	1565	6XM16
DW25-5	2900	30	65	40	310	640	600	321	1400	550	150	462	685	630	1615	6XM16
DW25-6	2900	37	65	40	365	640	600	321	1550	600	175	627	685	630	1730	6XM16
DW25-7	2900	45	65	40	420	640	600	366	1700	650	200	682	705	695	1830	6XM16
DW25-8	2900	45	65	40	475	640	600	366	1700	650	200	682	705	695	1830	6XM16
DW25-9	2900	55	65	40	530	740	700	395	1850	700	225	737	795	750	2010	6XM16
DW25-10	2900	55	65	40	585	740	700	395	1850	700	225	737	795	750	2060	6XM16
DW25-11	2900	75	65	40	640	850	800	445	2000	750	250	847	885	905	2200	6XM20
DW25-12	2900	75	65	40	695	850	800	445	2000	750	250	847	885	905	2250	6XM20
DW38-1	2900	11	65	40	90	540	500	281	1250	500	125	352	550	500	1275	6XM16
DW38-2	2900	15	65	40	145	540	500	281	1250	500	125	352	550	500	1275	6XM16
DW38-3	2900	18.5	65	40	200	540	500	281	1250	500	125	352	550	500	1370	6XM16
DW38-4	2900	30	65	40	255	640	600	321	1400	550	150	462	685	630	1565	6XM16
DW38-5	2900	30	65	40	310	640	600	321	1400	550	150	462	685	630	1615	6XM16
DW38-6	2900	37	65	40	365	640	600	321	1550	600	175	627	685	630	1730	6XM16
DW38-7	2900	45	65	40	420	640	600	366	1700	650	200	682	705	695	1830	6XM16
DW38-8	2900	45	65	40	475	640	600	366	1700	650	200	682	705	695	1830	6XM16
DW38-9	2900	55	65	40	530	740	700	395	1850	700	225	737	795	750	2010	6XM16
DW38-10	2900	55	65	40	585	740	700	395	1850	700	225	737	795	750	2060	6XM16
DW38-11	2900	75	65	40	640	850	800	445	2000	750	250	847	885	905	2200	6XM20
DW38-12	2900	75	65	40	695	850	800	445	2000	750	250	847	885	905	2250	6XM20

型号	转速	功率	DNS	DND	a1	B1	B2	H	L1	L2	L3	L4	BG	HG	LG	FB
DW58-1	2900	22	100	65	110	540	500	301	1250	500	125	355	550	540	1385	6XM16
DW58-2	2900	37	100	65	180	640	600	321	1400	550	150	355	685	630	1550	6XM16
DW58-3	2900	55	100	65	250	740	700	395	1550	600	175	425	795	750	1790	6XM16
DW58-4	2900	75	100	65	320	850	800	445	1700	650	200	495	885	705	1940	6XM20
DW58-5	2900	90	100	65	390	850	800	445	1850	700	225	635	885	905	2020	6XM20
DW58-6	2900	110	100	65	460	850	800	480	2000	750	250	705	935	995	2210	6XM20
DW58-7	2900	132	100	65	530	850	800	480	2000	750	250	705	935	995	2285	6XM20
DW58-8	2900	160	100	65	600	850	800	480	2150	800	275	845	935	995	2365	6XM20
DW58-9	2900	160	100	65	670	850	800	480	2150	800	275	845	935	995	2425	6XM20
DW78-1	2900	22	100	65	110	540	500	301	1250	500	125	355	550	540	1385	6XM16
DW78-2	2900	37	100	65	180	640	600	321	1400	550	150	355	685	630	1550	6XM16
DW78-3	2900	55	100	65	250	740	700	395	1550	600	175	425	795	750	1790	6XM16
DW78-4	2900	75	100	65	320	850	800	445	1700	650	200	495	885	705	1940	6XM20
DW78-5	2900	90	100	65	390	850	800	445	1850	700	225	635	885	905	2020	6XM20
DW78-6	2900	110	100	65	460	850	800	480	2000	750	250	705	935	995	2210	6XM20
DW78-7	2900	132	100	65	530	850	800	480	2000	750	250	705	935	995	2285	6XM20
DW78-8	2900	160	100	65	600	850	800	480	2150	800	275	845	935	995	2365	6XM20
DW78-9	2900	160	100	65	670	850	800	480	2150	800	275	845	935	995	2425	6XM20
DW120-1	2900	75	125	100	170	850	800	445	1700	650	200	477	925	910	1935	6XM20
DW120-2	2900	110	125	100	255	850	800	503	1850	700	225	562	985	1030	2195	6XM20
DW120-3	2900	160	125	100	340	850	800	503	1850	700	225	562	985	1030	2180	6XM20
DW120-4	2900	200	125	100	425	970	900	583	2300	875	275	647	1125	1185	2485	6XM24
DW120-5	2900	250	125	100	510	970	900	583	2450	950	275	817	1125	1185	2600	6XM24
DW120-6	2900	250	125	100	595	970	900	583	2450	950	275	817	1125	1185	2655	6XM24

型号	转速	功率	DNS	DND	a1	B1	B2	H	L1	L2	L3	L4	BG	HG	LG	FB
DW170-1	2900	75	125	100	170	850	800	445	1700	650	200	477	925	910	1935	6XM20
DW170-2	2900	110	125	100	255	850	800	503	1850	700	225	562	985	1030	2195	6XM20
DW170-3	2900	160	125	100	340	850	800	503	1850	700	225	562	985	1030	2180	6XM20
DW170-4	2900	200	125	100	425	970	900	583	2300	875	275	647	1125	1185	2485	6XM24
DW170-5	2900	250	125	100	510	970	900	583	2450	950	275	817	1125	1185	2600	6XM24
DW170-6	2900	250	125	100	595	970	900	583	2450	950	275	817	1125	1185	2655	6XM24
DW220-1	2900	132	150	125	210	850	800	503	1850	700	225	457	985	1030	2195	6XM20
DW220-2	2900	250	150	125	315	970	900	543	2300	875	275	562	1065	1145	2520	6XM24
DW220-3	2900	315	150	125	420	970	900	583	2300	875	275	667	1065	1185	2710	6XM24
DW220-4	2900	400	150	125	525	1070	1000	693	2600	1025	275	772	1150	1300	2960	6XM24
DW220-5	2900	450	150	125	630	1070	1000	693	2750	1100	275	877	1150	1300	3065	6XM24
DW280-1	2900	132	150	125	210	850	800	503	1850	700	225	457	985	1030	2195	6XM20
DW280-2	2900	250	150	125	315	970	900	543	2300	875	275	562	1065	1145	2520	6XM24
DW280-3	2900	315	150	125	420	970	900	583	2300	875	275	667	1065	1185	2710	6XM24
DW280-4	2900	400	150	125	525	1070	1000	693	2600	1025	275	772	1150	1300	2960	6XM24
DW280-5	2900	450	150	125	630	1070	1000	693	2750	1100	275	877	1150	1300	3065	6XM24

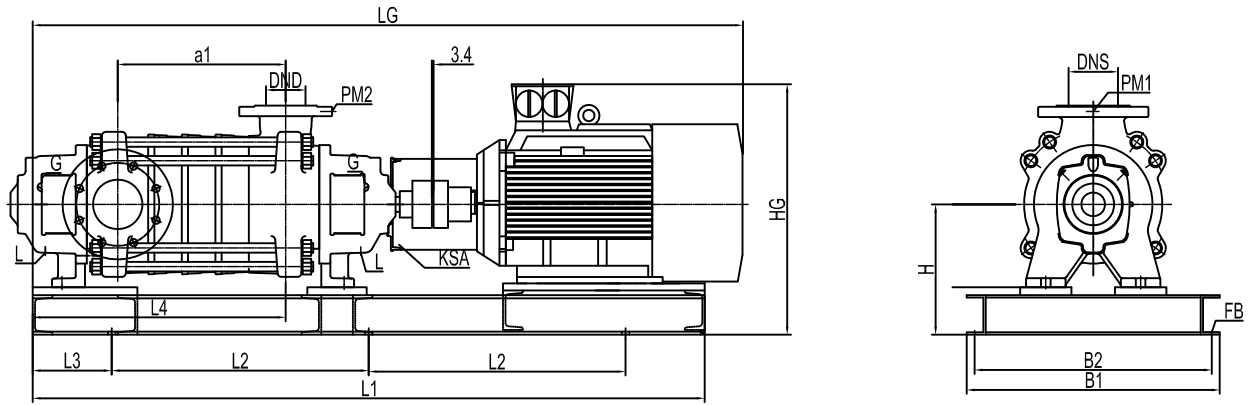

型号	转速	功率	DNS	DND	a1	B1	B2	H	L1	L2	L3	L4	BG	HG	LG	FB
DW16-1	1450	1.5	40	25	90	440	400	241	950	400	75	352	450	430	975	6XM16
DW16-2	1450	2.2	40	25	145	440	400	241	950	400	75	352	450	430	1020	6XM16
DW16-3	1450	3	40	25	200	440	400	241	950	400	75	352	450	430	1070	6XM16
DW16-4	1450	4	40	25	255	440	400	241	1100	450	100	517	450	430	1190	6XM16
DW16-5	1450	4	40	25	310	440	400	241	1100	450	100	517	450	430	1190	6XM16
DW16-6	1450	5.5	40	25	365	440	400	241	1250	500	125	517	450	430	1390	6XM16
DW16-7	1450	5.5	40	25	420	440	400	241	1400	550	150	682	450	430	1505	6XM16
DW16-8	1450	7.5	40	25	475	440	400	241	1400	550	150	682	450	430	1505	6XM16
DW16-9	1450	7.5	40	25	530	440	400	241	1400	550	150	682	450	430	1555	6XM16
DW16-10	1450	7.5	40	25	585	440	400	261	1550	600	175	847	450	450	1670	6XM16
DW16-11	1450	7.5	40	25	640	440	400	261	1550	600	175	847	450	450	1670	6XM16
DW16-12	1450	11	40	25	695	540	500	281	1700	650	200	847	550	500	1820	6XM16

型号	转速	功率	DNS	DND	a1	B1	B2	H	L1	L2	L3	L4	BG	HG	LG	FB
DW16-13	1450	11	40	25	750	540	500	301	1850	700	225	1012	550	520	1935	6XM16
DW16-14	1450	11	40	25	805	540	500	301	1850	700	225	1012	550	520	1935	6XM16
DW16-15	1450	15	40	25	860	540	500	301	1850	700	225	1012	550	520	2030	6XM16
DW16-16	1450	15	40	25	915	540	500	301	2000	750	250	1177	550	520	2145	6XM16
DW16-17	1450	15	40	25	970	540	500	301	2000	750	250	1177	550	520	2145	6XM16
DW16-18	1450	15	40	25	1025	540	500	301	2000	750	250	1177	550	520	2195	6XM16
DW25-1	1450	1.5	65	40	90	440	400	241	950	400	75	352	450	430	975	6XM16
DW25-2	1450	2.2	65	40	145	440	400	241	950	400	75	352	450	430	1020	6XM16
DW25-3	1450	3	65	40	200	440	400	241	950	400	75	352	450	430	1070	6XM16
DW25-4	1450	4	65	40	255	440	400	241	1100	450	100	517	450	430	1190	6XM16
DW25-5	1450	4	65	40	310	440	400	241	1100	450	100	517	450	430	1190	6XM16
DW25-6	1450	5.5	65	40	365	440	400	241	1250	500	125	517	450	430	1390	6XM16
DW25-7	1450	5.5	65	40	420	440	400	241	1400	550	150	682	450	430	1505	6XM16
DW25-8	1450	7.5	65	40	475	440	400	241	1400	550	150	682	450	430	1505	6XM16
DW25-9	1450	7.5	65	40	530	440	400	241	1400	550	150	682	450	430	1555	6XM16
DW25-10	1450	7.5	65	40	585	440	400	261	1550	600	175	847	450	450	1670	6XM16
DW25-11	1450	7.5	65	40	640	440	400	261	1550	600	175	847	450	450	1670	6XM16
DW25-12	1450	11	65	40	695	540	500	281	1700	650	200	847	550	500	1820	6XM16
DW25-13	1450	11	65	40	750	540	500	301	1850	700	225	1012	550	520	1935	6XM16
DW25-14	1450	11	65	40	805	540	500	301	1850	700	225	1012	550	520	1935	6XM16
DW25-15	1450	15	65	40	860	540	500	301	1850	700	225	1012	550	520	2030	6XM16
DW25-16	1450	15	65	40	915	540	500	301	2000	750	250	1177	550	520	2145	6XM16
DW25-17	1450	15	65	40	970	540	500	301	2000	750	250	1177	550	520	2145	6XM16
DW25-18	1450	15	65	40	1025	540	500	301	2000	750	250	1177	550	520	2195	6XM16
DW38-1	1450	1.5	65	40	90	440	400	241	950	400	75	352	450	430	975	6XM16

型号	转速	功率	DNS	DND	a1	B1	B2	H	L1	L2	L3	L4	BG	HG	LG	FB
DW38-2	1450	2.2	65	40	145	440	400	241	950	400	75	352	450	430	1020	6XM16
DW38-3	1450	3	65	40	200	440	400	241	950	400	75	352	450	430	1070	6XM16
DW38-4	1450	4	65	40	255	440	400	241	1100	450	100	517	450	430	1190	6XM16
DW38-5	1450	4	65	40	310	440	400	241	1100	450	100	517	450	430	1190	6XM16
DW38-6	1450	5.5	65	40	365	440	400	241	1250	500	125	517	450	430	1390	6XM16
DW38-7	1450	5.5	65	40	420	440	400	241	1400	550	150	682	450	430	1505	6XM16
DW38-8	1450	7.5	65	40	475	440	400	241	1400	550	150	682	450	430	1505	6XM16
DW38-9	1450	7.5	65	40	530	440	400	241	1400	550	150	682	450	430	1555	6XM16
DW38-10	1450	7.5	65	40	585	440	400	261	1550	600	175	847	450	450	1670	6XM16
DW38-11	1450	7.5	65	40	640	440	400	261	1550	600	175	847	450	450	1670	6XM16
DW38-12	1450	11	65	40	695	540	500	281	1700	650	200	847	550	500	1820	6XM16
DW38-13	1450	11	65	40	750	540	500	301	1850	700	225	1012	550	520	1935	6XM16
DW38-14	1450	11	65	40	805	540	500	301	1850	700	225	1012	550	520	1935	6XM16
DW38-15	1450	15	65	40	860	540	500	301	1850	700	225	1012	550	520	2030	6XM16
DW38-16	1450	15	65	40	915	540	500	301	2000	750	250	1177	550	520	2145	6XM16
DW38-17	1450	15	65	40	970	540	500	301	2000	750	250	1177	550	520	2145	6XM16
DW38-18	1450	15	65	40	1025	540	500	301	2000	750	250	1177	550	520	2195	6XM16
DW58-1	1450	4	100	65	110	440	400	261	1100	450	100	355	450	480	1110	6XM16
DW58-2	1450	5.5	100	65	180	440	400	261	1250	500	125	425	450	480	1280	6XM16
DW58-3	1450	7.5	100	65	250	440	400	261	1250	500	125	425	450	480	1340	6XM16
DW58-4	1450	11	100	65	320	540	500	281	1400	550	150	495	550	500	1510	6XM16
DW58-5	1450	15	100	65	390	540	500	281	1550	600	175	635	550	500	1635	6XM16
DW58-6	1450	15	100	65	460	540	500	281	1550	600	175	635	550	500	1695	6XM16
DW58-7	1450	18.5	100	65	530	540	500	281	1700	650	200	775	550	540	1805	6XM16
DW58-8	1450	18.5	100	65	600	540	500	301	1700	650	200	775	550	540	1865	6XM16

型号	转速	功率	DNS	DND	a1	B1	B2	H	L1	L2	L3	L4	BG	HG	LG	FB
DW58-9	1450	22	100	65	670	540	500	321	1850	700	225	915	550	560	1945	6XM16
DW58-10	1450	30	100	65	740	640	600	341	2000	750	250	915	685	650	2110	6XM16
DW58-11	1450	30	100	65	810	650	600	361	2150	800	275	1055	690	670	2190	6XM20
DW58-12	1450	30	100	65	880	650	600	361	2150	800	275	1055	690	670	2250	6XM20
DW58-13	1450	30	100	65	950	650	600	361	2150	800	275	1195	690	670	2330	6XM20
DW58-14	1450	30	100	65	1020	650	600	361	2150	800	275	1195	690	670	2390	6XM20
DW78-1	1450	4	100	65	110	440	400	261	1100	450	100	355	450	480	1110	6XM16
DW78-2	1450	5.5	100	65	180	440	400	261	1250	500	125	425	450	480	1280	6XM16
DW78-3	1450	7.5	100	65	250	440	400	261	1250	500	125	425	450	480	1340	6XM16
DW78-4	1450	11	100	65	320	540	500	281	1400	550	150	495	550	500	1510	6XM16
DW78-5	1450	15	100	65	390	540	500	281	1550	600	175	635	550	500	1635	6XM16
DW78-6	1450	15	100	65	460	540	500	281	1550	600	175	635	550	500	1695	6XM16
DW78-7	1450	18.5	100	65	530	540	500	281	1700	650	200	775	550	540	1805	6XM16
DW78-8	1450	18.5	100	65	600	540	500	301	1700	650	200	775	550	540	1865	6XM16
DW78-9	1450	22	100	65	670	540	500	321	1850	700	225	915	550	560	1945	6XM16
DW78-10	1450	30	100	65	740	640	600	341	2000	750	250	915	685	650	2110	6XM16
DW78-11	1450	30	100	65	810	650	600	361	2150	800	275	1055	690	670	2190	6XM20
DW78-12	1450	30	100	65	880	650	600	361	2150	800	275	1055	690	670	2250	6XM20
DW78-13	1450	30	100	65	950	650	600	361	2150	800	275	1195	690	670	2330	6XM20
DW78-14	1450	30	100	65	1020	650	600	361	2150	800	275	1195	690	670	2390	6XM20
DW120-1	1450	15	125	100	170	540	500	335	1400	550	150	477	550	585	1515	6XM16
DW120-2	1450	15	125	100	255	540	500	335	1400	550	150	477	550	585	1575	6XM16
DW120-3	1450	22	125	100	340	540	500	335	1550	600	175	562	550	600	1700	6XM16
DW120-4	1450	30	125	100	425	640	600	335	1700	650	200	647	685	630	1880	6XM16
DW120-5	1450	37	125	100	510	640	600	366	1850	700	225	817	705	695	2070	6XM16

型号	转速	功率	DNS	DND	a1	B1	B2	H	L1	L2	L3	L4	BG	HG	LG	FB
DW120-6	1450	45	125	100	595	640	600	366	1850	700	225	817	705	695	2125	6XM16
DW120-7	1450	45	125	100	680	650	600	386	2150	800	275	987	710	715	2240	6XM20
DW120-8	1450	55	125	100	765	750	700	415	2150	800	275	987	800	765	2390	6XM20
DW120-9	1450	55	125	100	850	750	700	415	2300	875	275	1157	800	765	2505	6XM20
DW120-10	1450	55	125	100	935	750	700	415	2300	875	275	1157	800	765	2560	6XM20
DW170-1	1450	15	125	100	170	540	500	335	1400	550	150	477	550	585	1515	6XM16
DW170-2	1450	15	125	100	255	540	500	335	1400	550	150	477	550	585	1575	6XM16
DW170-3	1450	22	125	100	340	540	500	335	1550	600	175	562	550	600	1700	6XM16
DW170-4	1450	30	125	100	425	640	600	335	1700	650	200	647	685	630	1880	6XM16
DW170-5	1450	37	125	100	510	640	600	366	1850	700	225	817	705	695	2070	6XM16
DW170-6	1450	45	125	100	595	640	600	366	1850	700	225	817	705	695	2125	6XM16
DW170-7	1450	45	125	100	680	650	600	386	2150	800	275	987	710	715	2240	6XM20
DW170-8	1450	55	125	100	765	750	700	415	2150	800	275	987	800	765	2390	6XM20
DW170-9	1450	55	125	100	850	750	700	415	2300	875	275	1157	800	765	2505	6XM20
DW170-10	1450	55	125	100	935	750	700	415	2300	875	275	1157	800	765	2560	6XM20
DW220-1	1450	15	150	125	210	640	600	375	1550	600	175	457	650	675	1670	6XM16
DW220-2	1450	30	150	125	315	640	600	375	1700	650	200	562	685	675	1915	6XM16
DW220-3	1450	45	150	125	420	640	600	395	1850	700	225	667	705	725	2095	6XM16
DW220-4	1450	55	150	125	525	740	700	395	2000	750	250	772	795	745	2295	6XM16
DW220-5	1450	75	150	125	630	850	800	445	2150	800	275	877	925	910	2510	6XM20
DW220-6	1450	90	150	125	735	850	800	445	2300	875	275	982	925	910	2615	6XM20
DW220-7	1450	110	150	125	840	850	800	503	2600	1025	275	1087	985	1030	2855	6XM20
DW220-8	1450	110	150	125	945	850	800	503	2600	1025	275	1192	985	1030	2960	6XM20
DW280-1	1450	15	150	125	210	640	600	375	1550	600	175	457	650	675	1670	6XM16
DW280-2	1450	30	150	125	315	640	600	375	1700	650	200	562	685	675	1915	6XM16

型号	转速	功率	DNS	DND	a1	B1	B2	H	L1	L2	L3	L4	BG	HG	LG	FB
DW280-3	1450	45	150	125	420	640	600	395	1850	700	225	667	705	725	2095	6XM16
DW280-4	1450	55	150	125	525	740	700	395	2000	750	250	772	795	745	2295	6XM16
DW280-5	1450	75	150	125	630	850	800	445	2150	800	275	877	925	910	2510	6XM20
DW280-6	1450	90	150	125	735	850	800	445	2300	875	275	982	925	910	2615	6XM20
DW280-7	1450	110	150	125	840	850	800	503	2600	1025	275	1087	985	1030	2855	6XM20
DW280-8	1450	110	150	125	945	850	800	503	2600	1025	275	1192	985	1030	2960	6XM20